

**Appendix F:
Water Quality Management Plan**

THIS PAGE INTENTIONALLY LEFT BLANK

Project Specific Water Quality Management Plan

A Template for Projects located within the **Santa Ana Watershed** Region of Riverside County

Project Title: Palmyrita Avenue Warehouses

Development No: .

Design Review/Case No: .

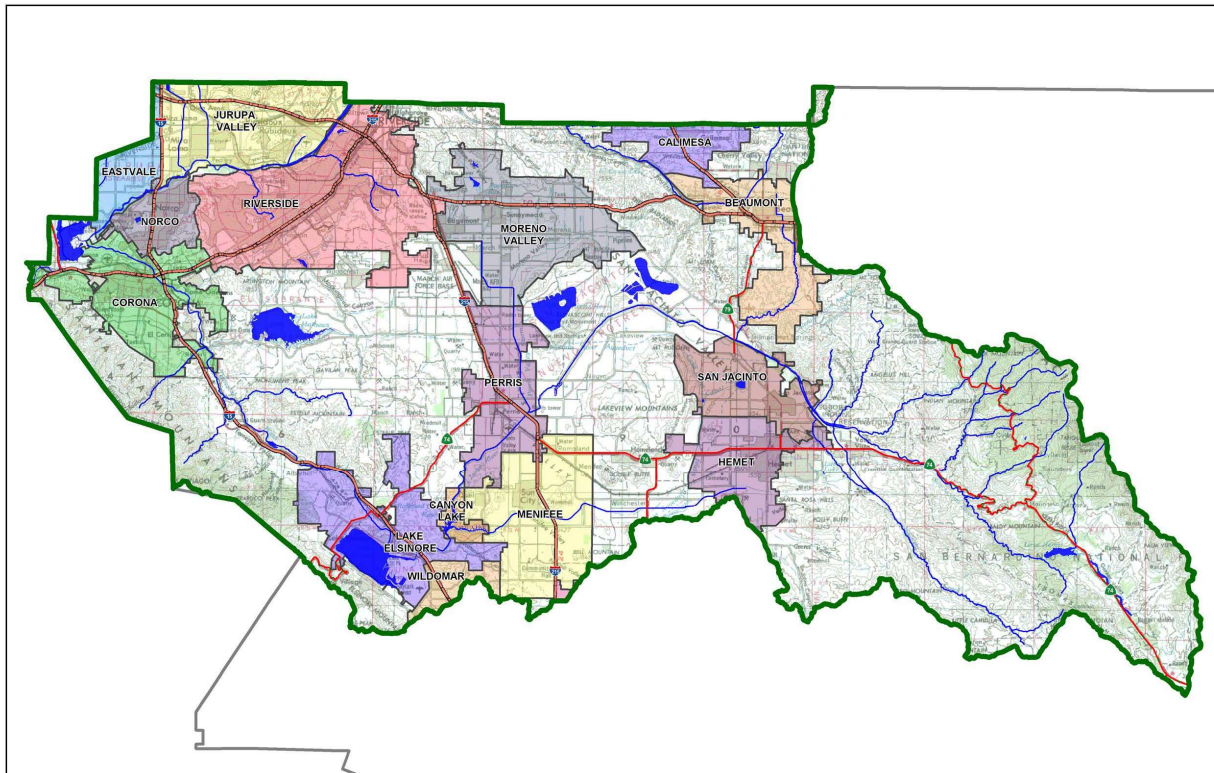

Contact Information:

Prepared for:

Dedeaux Properties
1430 S. Eastman Avenue
Los Angeles, CA 90023
909-730-0186

Prepared by:

Douglas L. Goodman, Owner
Goodman & Associates, Inc.
2079 Sky View Drive
Colton, CA 92324
(909) 824-2775

- Preliminary
- Final

Original Date Prepared: July 11, 2022

Revision Date(s): .

*Prepared for Compliance with
Regional Board Order No. **R8-2010-0033***

Template revised June 30, 2016

A Brief Introduction

This Project-Specific WQMP Template for the **Santa Ana Region** has been prepared to help guide you in documenting compliance for your project. Because this document has been designed to specifically document compliance, you will need to utilize the WQMP Guidance Document as your “how-to” manual to help guide you through this process. Both the Template and Guidance Document go hand-in-hand, and will help facilitate a well prepared Project-Specific WQMP. Below is a flowchart for the layout of this Template that will provide the steps required to document compliance.

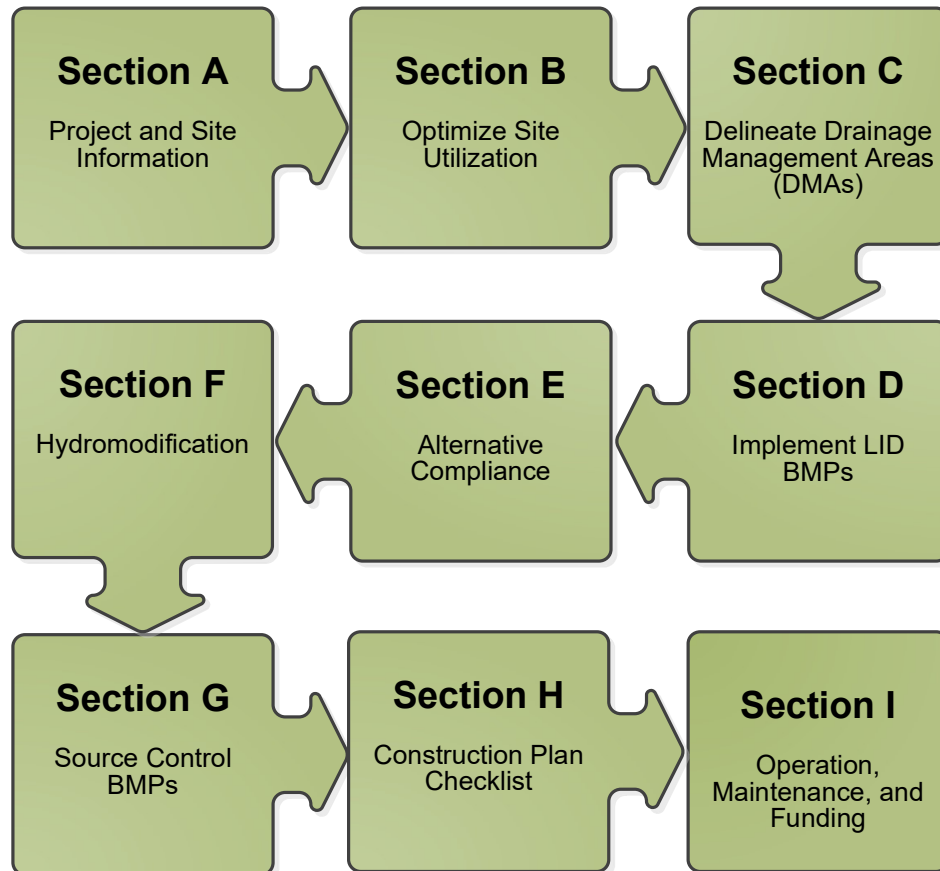

OWNER'S CERTIFICATION

This Project-Specific Water Quality Management Plan (WQMP) has been prepared for Dedeaux Properties by Goodman & Associates, Inc. for the Palmyrita Avenue Warehouses project.

This WQMP is intended to comply with the requirements of the City of Riverside for Palmyrita Avenue Warehouses, Planning Case . which includes the requirement for the preparation and implementation of a Project-Specific WQMP.

The undersigned, while owning the property/project described in the preceding paragraph, shall be responsible for the implementation and funding of this WQMP and will ensure that this WQMP is amended as appropriate to reflect up-to-date conditions on the site. In addition, the property owner accepts responsibility for interim operation and maintenance of Stormwater BMPs until such time as this responsibility is formally transferred to a subsequent owner. This WQMP will be reviewed with the facility operator, facility supervisors, employees, tenants, maintenance and service contractors, or any other party (or parties) having responsibility for implementing portions of this WQMP. At least one copy of this WQMP will be maintained at the project site or project office in perpetuity. The undersigned is authorized to certify and to approve implementation of this WQMP. The undersigned is aware that implementation of this WQMP is enforceable under the City of Riverside Water Quality Ordinance (Municipal Code Section 1194).

"I, the undersigned, certify under penalty of law that the provisions of this WQMP have been reviewed and accepted and that the WQMP will be transferred to future successors in interest."

Owner's Signature

Benjamin Horning
Owner's Printed Name

Date

Owner Representative
Owner's Title/Position

PREPARER'S CERTIFICATION

"The selection, sizing and design of stormwater treatment and other stormwater quality and quantity control measures in this plan meet the requirements of Regional Water Quality Control Board Order No. **R8-2010-0033** and any subsequent amendments thereto."

Preparer's Signature

Douglas L. Goodman
Preparer's Printed Name

Date

Owner
Preparer's Title/Position

Preparer's Licensure: RCE 28500, Expires March 31, 2024

Table of Contents

Section A: Project and Site Information.....	6
A.1 Maps and Site Plans.....	7
A.2 Identify Receiving Waters.....	7
A.3 Additional Permits/Approvals required for the Project:	7
Section B: Optimize Site Utilization (LID Principles)	9
Section C: Delineate Drainage Management Areas (DMAs).....	10
Section D: Implement LID BMPs	13
D.1 Infiltration Applicability	13
D.2 Harvest and Use Assessment.....	14
D.3 Bioretention and Biotreatment Assessment.....	16
D.4 Feasibility Assessment Summaries	17
D.5 LID BMP Sizing	18
Section E: Alternative Compliance (LID Waiver Program).....	20
E.1 Identify Pollutants of Concern	21
E.2 Stormwater Credits	22
E.3 Sizing Criteria.....	22
E.4 Treatment Control BMP Selection	23
Section F: Hydromodification	24
F.1 Hydrologic Conditions of Concern (HCOC) Analysis.....	24
F.2 HCOC Mitigation.....	25
Section G: Source Control BMPs.....	26
Section H: Construction Plan Checklist	29
Section I: Operation, Maintenance and Funding.....	30

List of Tables

Table A.1 Identification of Receiving Waters.....	7
Table A.2 Other Applicable Permits.....	7
Table C.1 DMA Classifications.....	10
Table C.2 Type 'A', Self-Treating Areas.....	10
Table C.3 Type 'B', Self-Retaining Areas.....	11
Table C.4 Type 'C', Areas that Drain to Self-Retaining Areas.....	11
Table C.5 Type 'D', Areas Draining to BMPs.....	12
Table D.1 Infiltration Feasibility.....	13
Table D.2 LID Prioritization Summary Matrix.....	17
Table D.3 DCV Calculations for LID BMPs.....	18
Table E.1 Potential Pollutants by Land Use Type.....	21
Table E.2 Water Quality Credits.....	22
Table E.3 Treatment Control BMP Sizing.....	22
Table E.4 Treatment Control BMP Selection.....	23
Table F.1 Hydrologic Conditions of Concern Summary.....	24
Table G.1 Permanent and Operational Source Control Measures.....	26
Table H.1 Construction Plan Cross-reference.....	29

List of Appendices

Appendix 1: Maps and Site Plans.....	31
Appendix 2: Construction Plans.....	32
Appendix 3: Soils Information.....	33
Appendix 4: Historical Site Conditions.....	34
Appendix 5: LID Infeasibility.....	35
Appendix 6: BMP Design Details.....	36
Appendix 7: Hydromodification.....	37
Appendix 8: Source Control.....	38
Appendix 9: O&M.....	39
Appendix 10: Educational Materials.....	- 6 -

Section A: Project and Site Information

The proposed project is for the construction of two warehouse buildings with truck loading docks and associated parking on approximately 13 acres. The project is located on Palmyrita Avenue, extending westerly to Iowa Avenue, south of Citrus Street, in the City of Riverside. Access to the proposed site will be from two driveway entrances off of Palmyrita Avenue and one driveway entrance of off Iowa Avenue.

The existing vacant property generally slopes from east to west at approximately 2%. Existing drainage sheet flows across the site. There is an existing storm drain pipe in Iowa Avenue.

The proposed project will consist of two warehouse buildings with associated parking, drive aisles, and landscaping. There are two proposed LID BMP, generally one for each building, along with CDS clarifiers for pre-treatment ahead of the underground infiltration systems. Each system is proposed to be situated to the west of each building. Over-flows in excess of water quality capture volume requirements will be conveyed off-site to Palmyrita Avenue.

PROJECT INFORMATION	
Type of Project:	Industrial/Warehouse
Planning Area:	Riverside
Community Name:	City of Riverside
Development Name:	Palmyrita Avenue Warehouses
PROJECT LOCATION	
Latitude & Longitude (DMS): 34.00541°N / 117.33927°W	
Project Watershed and Sub-Watershed: Santa Ana River	
Gross Acres: 13.6	
APN(s): 247-170-030 & 247-170-039	
Map Book and Page No.: Thomas Guide Book Riverside County Page 686 Grid C1	
PROJECT CHARACTERISTICS	
Proposed or Potential Land Use(s)	Warehouse
Proposed or Potential SIC Code(s)	4214
Area of Impervious Project Footprint (SF)	528,321 sf
Total Area of <u>proposed</u> Impervious Surfaces within the Project Footprint (SF)/or Replacement	528,321 sf
Does the project consist of offsite road improvements?	<input type="checkbox"/> Y <input checked="" type="checkbox"/> N
Does the project propose to construct unpaved roads?	<input type="checkbox"/> Y <input checked="" type="checkbox"/> N
Is the project part of a larger common plan of development (phased project)?	<input type="checkbox"/> Y <input checked="" type="checkbox"/> N
EXISTING SITE CHARACTERISTICS	
Total area of <u>existing</u> Impervious Surfaces within the Project limits Footprint (SF)	351,000 sf
Is the project located within any MSHCP Criteria Cell?	<input type="checkbox"/> Y <input checked="" type="checkbox"/> N
If so, identify the Cell number:	n/a
Are there any natural hydrologic features on the project site?	<input type="checkbox"/> Y <input checked="" type="checkbox"/> N
Is a Geotechnical Report attached?	<input checked="" type="checkbox"/> Y <input type="checkbox"/> N
If no Geotech. Report, list the NRCS soils type(s) present on the site (A, B, C and/or D)	A,C

A.1 Maps and Site Plans

When completing your Project-Specific WQMP, include a map of the local vicinity and existing site. In addition, include all grading, drainage, landscape/plant palette and other pertinent construction plans in Appendix 2. At a **minimum**, your WQMP Site Plan should include the following:

- Drainage Management Areas
- Proposed Structural BMPs
- Drainage Path
- Drainage Infrastructure, Inlets, Overflows
- Source Control BMPs
- Buildings, Roof Lines, Downspouts
- Impervious Surfaces
- Standard Labeling
- BMP Locations (Lat/Long)

Use your discretion on whether or not you may need to create multiple sheets or can appropriately accommodate these features on one or two sheets. Keep in mind that the Co-Permittee plan reviewer must be able to easily analyze your project utilizing this template and its associated site plans and maps.

A.2 Identify Receiving Waters

Using Table A.1 below, list in order of upstream to downstream, the receiving waters that the project site is tributary to. Continue to fill each row with the Receiving Water’s 303(d) listed impairments (if any), designated beneficial uses, and proximity, if any, to a RARE beneficial use. Include a map of the receiving waters in Appendix 1.

Table A.1 Identification of Receiving Waters

Receiving Waters	EPA Approved 303(d) List Impairments	Designated Beneficial Uses	Proximity to RARE Beneficial Use
Lake Evans	None	REC1, REC2, WARM, COLD, WHILD	N/A
Santa Ana River Reach 3	Copper, Lead, Pathogens	AGR,GWR,REC1,REC2,WARM,WILD,RARE,SPWN	1.3 MILES

A.3 Additional Permits/Approvals required for the Project:

Table A.2 Other Applicable Permits

Agency	Permit Required	
State Department of Fish and Game, 1602 Streambed Alteration Agreement	<input type="checkbox"/> Y	<input checked="" type="checkbox"/> N
State Water Resources Control Board, Clean Water Act (CWA) Section 401 Water Quality Cert.	<input type="checkbox"/> Y	<input checked="" type="checkbox"/> N
US Army Corps of Engineers, CWA Section 404 Permit	<input type="checkbox"/> Y	<input checked="" type="checkbox"/> N
US Fish and Wildlife, Endangered Species Act Section 7 Biological Opinion	<input type="checkbox"/> Y	<input checked="" type="checkbox"/> N
Statewide Construction General Permit Coverage	<input checked="" type="checkbox"/> Y	<input type="checkbox"/> N
Statewide Industrial General Permit Coverage	<input type="checkbox"/> Y	<input checked="" type="checkbox"/> N
Western Riverside MSHCP Consistency Approval (e.g., JPR, DBESP)	<input type="checkbox"/> Y	<input checked="" type="checkbox"/> N
Other (please list in the space below as required)	<input type="checkbox"/> Y	<input checked="" type="checkbox"/> N

If yes is answered to any of the questions above, the Co-Permittee may require proof of approval/coverage from those agencies as applicable including documentation of any associated requirements that may affect this Project-Specific WQMP.

Section B: Optimize Site Utilization (LID Principles)

Site Optimization

Did you identify and preserve existing drainage patterns? If so, how? If not, why?

The proposed project maintains this drainage pattern.

Did you identify and protect existing vegetation? If so, how? If not, why?

The existing parcel is a partially vacant parcel. The only vegetation on site are annual weeds and grasses typical of urban areas in Southern California. As such, the existing vegetation is ephemeral and not a permanent feature of the site. The proposed project will clear the existing site.

Did you identify and preserve natural infiltration capacity? If so, how? If not, why?

The project will preserve natural infiltration capacity where required for the proposed stormwater BMPs. The proposed landscaped areas will introduce planting media that will likely enhance the capability to store runoff on-site within the media. The infiltration capacity of the existing soils remains unchanged.

Did you identify and minimize impervious area? If so, how? If not, why?

The project is subject to numerous development requirements, including minimum number of parking stalls, minimum driveway widths, ADA standards, etc. The project meets these requirements with as small a footprint and as much landscaping as possible.

Did you identify and disperse runoff to adjacent pervious areas? If so, how? If not, why?

Some of the runoff will drain to nearby landscaping areas. The project calculations do not take credit for this as a treatment mechanism, however. The remainder of the project is designed to flow to the proposed BMPs shown on the plan. Stormwater is directed to these BMPs with minimal use of inlets and pipes (except for pretreatment needs), which is nearly equivalent to dispersing runoff to various pervious areas around the project.

Table C.3 Type 'B', Self-Retaining Areas

Self-Retaining Area				Type 'C' DMAs that are draining to the Self-Retaining Area		
DMA Name/ ID	Post-project surface type	Area (square feet) [A]	Storm Depth (inches) [B]	DMA Name / ID	[C] from Table C.4 = [C]	Required Retention Depth (inches) [D]

$$[D] = [B] + \frac{[B] \cdot [C]}{[A]}$$

Table C.4 Type 'C', Areas that Drain to Self-Retaining Areas

DMA					Receiving Self-Retaining DMA		
DMA Name/ ID	Area (square feet)	Post-project surface type	Impervious fraction	Product		Area (square feet)	Ratio
	[A]		[B]	[C] = [A] x [B]	DMA name /ID	[D]	[C]/[D]

Section D: Implement LID BMPs

D.1 Infiltration Applicability

Is there an approved downstream ‘Highest and Best Use’ for stormwater runoff (see discussion in Chapter 2.4.4 of the WQMP Guidance Document for further details)? Y N

Geotechnical Report

A Geotechnical Report or Phase I Environmental Site Assessment may be required by the Co-Permittee to confirm present and past site characteristics that may affect the use of Infiltration BMPs. In addition, the Co-Permittee, at their discretion, may not require a geotechnical report for small projects as described in Chapter 2 of the WQMP Guidance Document. If a geotechnical report has been prepared, include it in Appendix 3. In addition, if a Phase I Environmental Site Assessment has been prepared, include it in Appendix 4.

Is this project classified as a small project consistent with the requirements of Chapter 2 of the WQMP Guidance Document? Y N

Infiltration Feasibility

Table D.1 Infiltration Feasibility

Does the project site...	YES	NO
...have any DMAs with a seasonal high groundwater mark shallower than 10 feet? If Yes, list affected DMAs:		X
...have any DMAs located within 100 feet of a water supply well? If Yes, list affected DMAs:		X
...have any areas identified by the geotechnical report as posing a public safety risk where infiltration of stormwater could have a negative impact? If Yes, list affected DMAs:		X
...have measured in-situ infiltration rates of less than 1.6 inches / hour? If Yes, list affected DMAs: ALL	X	
...have significant cut and/or fill conditions that would preclude in-situ testing of infiltration rates at the final infiltration surface? If Yes, list affected DMAs:		X
...geotechnical report identify other site-specific factors that would preclude effective and safe infiltration? Describe here:		X

If you answered “Yes” to any of the questions above for any DMA, Infiltration BMPs should not be used for those DMAs and you should proceed to the assessment for Harvest and Use below.

D.2 Harvest and Use Assessment

Please check what applies:

- Reclaimed water will be used for the non-potable water demands for the project.
- Downstream water rights may be impacted by Harvest and Use as approved by the Regional Board (verify with the Co-Permittee).
- The Design Capture Volume will be addressed using Infiltration Only BMPs. In such a case, Harvest and Use BMPs are still encouraged, but it would not be required if the Design Capture Volume will be infiltrated or evapotranspired.

If any of the above boxes have been checked, Harvest and Use BMPs need not be assessed for the site. If none of the above criteria applies, follow the steps below to assess the feasibility of irrigation use, toilet use and other non-potable uses (e.g., industrial use).

Irrigation Use Feasibility

Complete the following steps to determine the feasibility of harvesting stormwater runoff for Irrigation Use BMPs on your site:

Step 1: Identify the total area of irrigated landscape on the site, and the type of landscaping used.

Total Area of Irrigated Landscape: 1.47 ac

Type of Landscaping (Conservation Design or Active Turf): Conservative Design

Step 2: Identify the planned total of all impervious areas on the proposed project from which runoff might be feasibly captured and stored for irrigation use. Depending on the configuration of buildings and other impervious areas on the site, you may consider the site as a whole, or parts of the site, to evaluate reasonable scenarios for capturing and storing runoff and directing the stored runoff to the potential use(s) identified in Step 1 above.

Total Area of Impervious Surfaces: 12.13 ac

Step 3: Cross reference the Design Storm depth for the project site (see Exhibit A of the WQMP Guidance Document) with the left column of Table 2-3 in Chapter 2 to determine the minimum area of Effective Irrigated Area per Tributary Impervious Area (EIATIA).

Enter your EIATIA factor: 1.05 ac

Step 4: Multiply the unit value obtained from Step 3 by the total of impervious areas from Step 2 to develop the minimum irrigated area that would be required.

Minimum required irrigated area: 12.74 ac

Step 5: Determine if harvesting stormwater runoff for irrigation use is feasible for the project by comparing the total area of irrigated landscape (Step 1) to the minimum required irrigated area (Step 4).

Minimum required irrigated area (Step 4)	Available Irrigated Landscape (Step 1)
12.74 ac	1.47 ac

Minimum required acreage not met; Irrigation Use not Feasible.

Toilet Use Feasibility

Complete the following steps to determine the feasibility of harvesting stormwater runoff for toilet flushing uses on your site:

Step 1: Identify the projected total number of daily toilet users during the wet season, and account for any periodic shut downs or other lapses in occupancy:

Projected Number of Daily Toilet Users: 200

Project Type: Industrial

Step 2: Identify the planned total of all impervious areas on the proposed project from which runoff might be feasibly captured and stored for toilet use. Depending on the configuration of buildings and other impervious areas on the site, you may consider the site as a whole, or parts of the site, to evaluate reasonable scenarios for capturing and storing runoff and directing the stored runoff to the potential use(s) identified in Step 1 above.

Total Area of Impervious Surfaces: 12.13 ac

Step 3: Enter the Design Storm depth for the project site (see Exhibit A) into the left column of Table 2-2 in Chapter 2 to determine the minimum number of toilet users per tributary impervious acre (TUTIA).

Enter your TUTIA factor: 185

Step 4: Multiply the unit value obtained from Step 3 by the total of impervious areas from Step 2 to develop the minimum number of toilet users that would be required.

Minimum number of toilet users: 2,244

Step 5: Determine if harvesting stormwater runoff for toilet flushing use is feasible for the project by comparing the Number of Daily Toilet Users (Step 1) to the minimum required number of toilet users (Step 4).

<u>Minimum required Toilet Users (Step 4)</u>	<u>Projected number of toilet users (Step 1)</u>
2,244	200

Therefore, Toilet Use is NOT feasible

Other Non-Potable Use Feasibility

Are there other non-potable uses for stormwater runoff on the site (e.g. industrial use)? See Chapter 2 of the Guidance for further information. If yes, describe below. If no, write N/A.

n/a

Step 1: Identify the projected average daily non-potable demand, in gallons per day, during the wet season and accounting for any periodic shut downs or other lapses in occupancy or operation.

Average Daily Demand: n/a

Step 2: Identify the planned total of all impervious areas on the proposed project from which runoff might be feasibly captured and stored for the identified non-potable use. Depending on the configuration of buildings and other impervious areas on the site, you may consider the site as a whole, or parts of the site, to evaluate reasonable scenarios for capturing and storing runoff and directing the stored runoff to the potential use(s) identified in Step 1 above.

Total Area of Impervious Surfaces: n/a

Step 3: Enter the Design Storm depth for the project site (see Exhibit A) into the left column of Table 2-4 in Chapter 2 to determine the minimum demand for non-potable uses per tributary impervious acre.

Enter the factor from Table 2-4: n/a

Step 4: Multiply the unit value obtained from Step 3 by the total of impervious areas from Step 2 to develop the minimum number of gallons per day of non-potable use that would be required.

Minimum required use: n/a

Step 5: Determine if harvesting stormwater runoff for other non-potable use is feasible for the project by comparing the projected average daily use (Step 1) to the minimum required non-potable use (Step 4).

Minimum required non-potable use (Step 4)	Projected average daily use (Step 1)
n/a	n/a

If Irrigation, Toilet and Other Use feasibility anticipated demands are less than the applicable minimum values, Harvest and Use BMPs are not required and you should proceed to utilize LID Bioretention and Biotreatment per Section 3.4.2 of the WQMP Guidance Document.

D.3 Bioretention and Biotreatment Assessment

Other LID Bioretention and Biotreatment BMPs as described in Chapter 2.4.7 of the WQMP Guidance Document are feasible on nearly all development sites with sufficient advance planning.

Select one of the following:

LID Bioretention/Biotreatment BMPs will be used for some or all DMAs of the project as noted below in Section D.4 (note the requirements of Section 3.4.2 in the WQMP Guidance Document).

A site-specific analysis demonstrating the technical infeasibility of all LID BMPs has been performed and is included in Appendix 5. If you plan to submit an analysis demonstrating the technical infeasibility of LID BMPs, request a pre-submittal meeting with the Co-Permittee to discuss this option. Proceed to Section E to document your alternative compliance measures.

D.4 Feasibility Assessment Summaries

From the Infiltration, Harvest and Use, Bioretention and Biotreatment Sections above, complete Table D.2 below to summarize which LID BMPs are technically feasible, and which are not, based upon the established hierarchy.

Table D.2 LID Prioritization Summary Matrix

DMA Name/ID	LID BMP Hierarchy				No LID (Alternative Compliance)
	1. Infiltration	2. Harvest and use	3. Bioretention	4. Biotreatment	
DA 1/A	<input type="checkbox"/>	<input type="checkbox"/>	<input type="checkbox"/>	<input checked="" type="checkbox"/>	<input type="checkbox"/>
	<input type="checkbox"/>	<input type="checkbox"/>	<input type="checkbox"/>	<input type="checkbox"/>	<input type="checkbox"/>
DA 2/B	<input type="checkbox"/>	<input type="checkbox"/>	<input type="checkbox"/>	<input checked="" type="checkbox"/>	<input type="checkbox"/>
	<input type="checkbox"/>	<input type="checkbox"/>	<input type="checkbox"/>	<input type="checkbox"/>	<input type="checkbox"/>

For those DMAs where LID BMPs are not feasible, provide a brief narrative below summarizing why they are not feasible, include your technical infeasibility criteria in Appendix 5, and proceed to Section E below to document Alternative Compliance measures for those DMAs. Recall that each proposed DMA must pass through the LID BMP hierarchy before alternative compliance measures may be considered.

n/a

D.5 LID BMP Sizing

Each LID BMP must be designed to ensure that the Design Capture Volume will be addressed by the selected BMPs. First, calculate the Design Capture Volume for each LID BMP using the V_{BMP} worksheet in Appendix F of the LID BMP Design Handbook. Second, design the LID BMP to meet the required V_{BMP} using a method approved by the Co-Permittee. Utilize the worksheets found in the LID BMP Design Handbook or consult with your Co-Permittee to assist you in correctly sizing your LID BMPs. Complete Table D.3 below to document the Design Capture Volume and the Proposed Volume for each LID BMP. Provide the completed design procedure sheets for each LID BMP in Appendix 6. You may add additional rows to the table below as needed.

Table D.3 DCV Calculations for LID BMPs

DMA Type/ID	DMA Area (square feet)	Post-Project Surface Type	Effective Impervious Fraction, I_r	DMA Runoff Factor	DMA Areas x Runoff Factor	Enter BMP Name / Identifier Here		
	[A]		[B]	[C]	[A] x [C]	BMP 1/Underground Bioretention with underdrain		
DA 1/A	266,282	Concrete or Asphalt	1	0.89	237,523.5	Design Storm Depth (in)	Design Capture Volume, V_{BMP} (cubic feet)	Proposed Volume on Plans (cubic feet)
DA 1/C	39,379	Ornamental Landscaping	0.1	0.11	4349.7			
	305,661				241,873.2	0.643	12,960.4	13,202

DMA Type/ID	DMA Area (square feet)	Post-Project Surface Type	Effective Impervious Fraction, I_f	DMA Runoff Factor	DMA Areas \times Runoff Factor	Enter BMP Name / Identifier Here		
	[A]		[B]	[C]	[A] \times [C]	BMP 2/ Underground Bioretention with underdrain		
DA 2/B	262,039	Concrete or Asphalt	1	0.89	233,738.8	Design Storm Depth (in)	Design Capture Volume, V_{BMP} (cubic feet)	Proposed Volume on Plans (cubic feet)
DA 2/D	24,747	Ornamental Landscaping	0.1	0.11	2733.5			
	286,786				236,472.3	0.643	12,671	13,202

[B], [C] is obtained as described in Section 2.3.1 of the WQMP Guidance Document

[E] is obtained from Exhibit A in the WQMP Guidance Document

[G] is obtained from a design procedure sheet, such as in LID BMP Design Handbook and placed in Appendix 6

Section E: Alternative Compliance (LID Waiver Program)

LID BMPs are expected to be feasible on virtually all projects. Where LID BMPs have been demonstrated to be infeasible as documented in Section D, other Treatment Control BMPs must be used (subject to LID waiver approval by the Copermittee). Check one of the following Boxes:

LID Principles and LID BMPs have been incorporated into the site design to fully address all Drainage Management Areas. No alternative compliance measures are required for this project and thus this Section is not required to be completed.

- Or -

The following Drainage Management Areas are unable to be addressed using LID BMPs. A site-specific analysis demonstrating technical infeasibility of LID BMPs has been approved by the Co-Permittee and included in Appendix 5. Additionally, no downstream regional and/or sub-regional LID BMPs exist or are available for use by the project. The following alternative compliance measures on the following pages are being implemented to ensure that any pollutant loads expected to be discharged by not incorporating LID BMPs, are fully mitigated.

E.1 Identify Pollutants of Concern

Utilizing Table A.1 from Section A above which noted your project's receiving waters and their associated EPA approved 303(d) listed impairments, cross reference this information with that of your selected Priority Development Project Category in Table E.1 below. If the identified General Pollutant Categories are the same as those listed for your receiving waters, then these will be your Pollutants of Concern and the appropriate box or boxes will be checked on the last row. The purpose of this is to document compliance and to help you appropriately plan for mitigating your Pollutants of Concern in lieu of implementing LID BMPs.

Table E.1 Potential Pollutants by Land Use Type

Priority Development Project Categories and/or Project Features (check those that apply)	General Pollutant Categories							
	Bacterial Indicators	Metals	Nutrients	Pesticides	Toxic Organic Compounds	Sediments	Trash & Debris	Oil & Grease
<input type="checkbox"/> Detached Residential Development	P	N	P	P	N	P	P	P
<input type="checkbox"/> Attached Residential Development	P	N	P	P	N	P	P	P ⁽²⁾
<input checked="" type="checkbox"/> Commercial/Industrial Development	P ⁽³⁾	P	P ⁽¹⁾	P ⁽¹⁾	P ⁽⁵⁾	P ⁽¹⁾	P	P
<input type="checkbox"/> Automotive Repair Shops	N	P	N	N	P ^(4, 5)	N	P	P
<input type="checkbox"/> Restaurants (>5,000 ft ²)	P	N	N	N	N	N	P	P
<input type="checkbox"/> Hillside Development (>5,000 ft ²)	P	N	P	P	N	P	P	P
<input type="checkbox"/> Parking Lots (>5,000 ft ²)	P ⁽⁶⁾	P	P ⁽¹⁾	P ⁽¹⁾	P ⁽⁴⁾	P ⁽¹⁾	P	P
<input type="checkbox"/> Retail Gasoline Outlets	N	P	N	N	P	N	P	P
Project Priority Pollutant(s) of Concern	<input checked="" type="checkbox"/>	<input checked="" type="checkbox"/>	<input checked="" type="checkbox"/>	<input checked="" type="checkbox"/>	<input checked="" type="checkbox"/>	<input checked="" type="checkbox"/>	<input checked="" type="checkbox"/>	<input checked="" type="checkbox"/>

P = Potential

N = Not Potential

⁽¹⁾ A potential Pollutant if non-native landscaping exists or is proposed onsite; otherwise not expected

⁽²⁾ A potential Pollutant if the project includes uncovered parking areas; otherwise not expected

⁽³⁾ A potential Pollutant is land use involving animal waste

⁽⁴⁾ Specifically petroleum hydrocarbons

⁽⁵⁾ Specifically solvents

⁽⁶⁾ Bacterial indicators are routinely detected in pavement runoff

E.2 Stormwater Credits

Projects that cannot implement LID BMPs but nevertheless implement smart growth principles are potentially eligible for Stormwater Credits. Utilize Table 3-8 within the WQMP Guidance Document to identify your Project Category and its associated Water Quality Credit. If not applicable, write N/A.

Table E.2 Water Quality Credits

Qualifying Project Categories	Credit Percentage ²
n/a	
<i>Total Credit Percentage¹</i>	

¹Cannot Exceed 50%

²Obtain corresponding data from Table 3-8 in the WQMP Guidance Document

E.3 Sizing Criteria

After you appropriately considered Stormwater Credits for your project, utilize Table E.3 below to appropriately size them to the DCV, or Design Flow Rate, as applicable. Please reference Chapter 3.5.2 of the WQMP Guidance Document for further information.

Table E.3 Treatment Control BMP Sizing

DMA Type/ID	DMA Area (square feet)	Post-Project Surface Type	Effective Impervious Fraction, I _f	DMA Runoff Factor	DMA Area x Runoff Factor	Enter BMP Name / Identifier Here			
	[A]		[B]	[C]	[A] x [C]				
n/a									
						<i>Design Storm Depth (in)</i> <i>Minimum Design Capture Volume or Design Flow Rate (cubic feet or cfs)</i> <i>Total Storm Water Credit % Reduction</i> <i>Proposed Volume or Flow on Plans (cubic feet or cfs)</i>			
	$A_T = \sum[A]$				$\sum = [D]$	[E]	$[F] = \frac{[D] \times [E]}{[G]}$	$[F] \times (1 - [H])$	[I]

[B], [C] is obtained as described in Section 2.3.1 from the WQMP Guidance Document

[E] is for Flow-Based Treatment Control BMPs [E] = .2, for Volume-Based Control Treatment BMPs, [E] obtained from Exhibit A in the WQMP Guidance Document

[G] is for Flow-Based Treatment Control BMPs [G] = 43,560, for Volume-Based Control Treatment BMPs, [G] = 12

[H] is from the Total Credit Percentage as Calculated from Table E.2 above

[I] as obtained from a design procedure sheet from the BMP manufacturer and should be included in Appendix 6

E.4 Treatment Control BMP Selection

Treatment Control BMPs typically provide proprietary treatment mechanisms to treat potential pollutants in runoff, but do not sustain significant biological processes. Treatment Control BMPs must have a removal efficiency of a medium or high effectiveness as quantified below:

- **High:** equal to or greater than 80% removal efficiency
- **Medium:** between 40% and 80% removal efficiency

Such removal efficiency documentation (e.g., studies, reports, etc.) as further discussed in Chapter 3.5.2 of the WQMP Guidance Document, must be included in Appendix 6. In addition, ensure that proposed Treatment Control BMPs are properly identified on the WQMP Site Plan in Appendix 1.

Table E.4 Treatment Control BMP Selection

Selected Treatment Control BMP Name or ID ¹	Priority Pollutant(s) of Concern to Mitigate ²	Removal Percentage ³	Efficiency
n/a			

¹ Treatment Control BMPs must not be constructed within Receiving Waters. In addition, a proposed Treatment Control BMP may be listed more than once if they possess more than one qualifying pollutant removal efficiency.

² Cross Reference Table E.1 above to populate this column.

³ As documented in a Co-Permittee Approved Study and provided in Appendix 6.

Section F: Hydromodification

F.1 Hydrologic Conditions of Concern (HCOC) Analysis

Once you have determined that the LID design is adequate to address water quality requirements, you will need to assess if the proposed LID Design may still create a HCOC. Review Chapters 2 and 3 (including Figure 3-7) of the WQMP Guidance Document to determine if your project must mitigate for Hydromodification impacts. If your project meets one of the following criteria which will be indicated by the check boxes below, you do not need to address Hydromodification at this time. However, if the project does not qualify for Exemptions 1, 2 or 3, then additional measures must be added to the design to comply with HCOC criteria. This is discussed in further detail below in Section F.2.

HCOC EXEMPTION 1: The Priority Development Project disturbs less than one acre. The Copermitttee has the discretion to require a Project-Specific WQMP to address HCOCs on projects less than one acre on a case by case basis. The disturbed area calculation should include all disturbances associated with larger common plans of development.

Does the project qualify for this HCOC Exemption? Y N

If Yes, HCOC criteria do not apply.

HCOC EXEMPTION 2: The volume and time of concentration¹ of storm water runoff for the post-development condition is not significantly different from the pre-development condition for a 2-year return frequency storm (a difference of 5% or less is considered insignificant) using one of the following methods to calculate:

- Riverside County Hydrology Manual
- Technical Release 55 (TR-55): Urban Hydrology for Small Watersheds (NRCS 1986), or derivatives thereof, such as the Santa Barbara Urban Hydrograph Method
- Other methods acceptable to the Co-Permittee

Does the project qualify for this HCOC Exemption? Y N

If Yes, report results in Table F.1 below and provide your substantiated hydrologic analysis in Appendix 7.

Table F.1 Hydrologic Conditions of Concern Summary

	2 year – 24 hour		
	Pre-condition	Post-condition	% Difference
Time of Concentration	n/a	n/a	
Volume (Cubic Feet)	n/a	n/a	

¹ Time of concentration is defined as the time after the beginning of the rainfall when all portions of the drainage basin are contributing to flow at the outlet.

HCOC EXEMPTION 3: All downstream conveyance channels to an adequate sump (for example, Prado Dam, Lake Elsinore, Canyon Lake, Santa Ana River, or other lake, reservoir or naturally erosion resistant feature) that will receive runoff from the project are engineered and regularly maintained to ensure design flow capacity; no sensitive stream habitat areas will be adversely affected; or are not identified on the Co-Permittees Hydromodification Susceptibility Maps. (No longer accepted by the Santa Ana Regional Waterboard)

Does the project qualify for this HCOC Exemption? Y N

If Yes, HCOC criteria do not apply and note below which adequate sump applies to this HCOC qualifier:

F.2 HCOC Mitigation

If none of the above HCOC Exemption Criteria are applicable, HCOC criteria is considered mitigated if they meet one of the following conditions:

- a. Additional LID BMPS are implemented onsite or offsite to mitigate potential erosion or habitat impacts as a result of HCOCs. This can be conducted by an evaluation of site-specific conditions utilizing accepted professional methodologies published by entities such as the California Stormwater Quality Association (CASQA), the Southern California Coastal Water Research Project (SCCRWP), or other Co-Permittee approved methodologies for site-specific HCOC analysis.
- b. The project is developed consistent with an approved Watershed Action Plan that addresses HCOC in Receiving Waters.
- c. Mimicking the pre-development hydrograph with the post-development hydrograph, for a 2-year return frequency storm. Generally, the hydrologic conditions of concern are not significant, if the post-development hydrograph is no more than 10% greater than pre-development hydrograph. In cases where excess volume cannot be infiltrated or captured and reused, discharge from the site must be limited to a flow rate no greater than 110% of the pre-development 2-year peak flow.

Be sure to include all pertinent documentation used in your analysis of the items a, b or c in Appendix 7.

The project is in an HCOC exempt area.

Section G: Source Control BMPs

Source control BMPs include permanent, structural features that may be required in your project plans — such as roofs over and berms around trash and recycling areas — and Operational BMPs, such as regular sweeping and “housekeeping”, that must be implemented by the site’s occupant or user. The MEP standard typically requires both types of BMPs. In general, Operational BMPs cannot be substituted for a feasible and effective permanent BMP. Using the Pollutant Sources/Source Control Checklist in Appendix 8, review the following procedure to specify Source Control BMPs for your site:

1. **Identify Pollutant Sources:** Review Column 1 in the Pollutant Sources/Source Control Checklist. Check off the potential sources of Pollutants that apply to your site.
2. **Note Locations on Project-Specific WQMP Exhibit:** Note the corresponding requirements listed in Column 2 of the Pollutant Sources/Source Control Checklist. Show the location of each Pollutant source and each permanent Source Control BMP in your Project-Specific WQMP Exhibit located in Appendix 1.
3. **Prepare a Table and Narrative:** Check off the corresponding requirements listed in Column 3 in the Pollutant Sources/Source Control Checklist. In the left column of Table G.1 below, list each potential source of runoff Pollutants on your site (from those that you checked in the Pollutant Sources/Source Control Checklist). In the middle column, list the corresponding permanent, Structural Source Control BMPs (from Columns 2 and 3 of the Pollutant Sources/Source Control Checklist) used to prevent Pollutants from entering runoff. **Add additional narrative** in this column that explains any special features, materials or methods of construction that will be used to implement these permanent, Structural Source Control BMPs.
4. **Identify Operational Source Control BMPs:** To complete your table, refer once again to the Pollutant Sources/Source Control Checklist. List in the right column of your table the Operational BMPs that should be implemented as long as the anticipated activities continue at the site. Copermittee stormwater ordinances require that applicable Source Control BMPs be implemented; the same BMPs may also be required as a condition of a use permit or other revocable Discretionary Approval for use of the site.

Table G.1 Permanent and Operational Source Control Measures

Potential Sources of Runoff pollutants	Permanent Structural Source Control BMPs	Operational Source Control BMPs
Landscaping/Outdoor Pesticide Use	<p>Final Landscape Plans will accomplish all of the following:</p> <ul style="list-style-type: none"> • Preserve existing native trees, shrubs, and ground cover to the maximum extent possible. • Design landscaping to minimize irrigation and runoff, to promote surface infiltration where appropriate, and to minimize 	<ul style="list-style-type: none"> • Maintain landscaping using minimum or no pesticides • Do not rake or blow leaves, clippings or pruning waste into the street, gutter or storm drain. Instead dispose of green waste by composting, hauling it to a permitted landfill, or recycling through the City of Riverside’s recycling program

	<p>the use of fertilizers and pesticides that can contribute to stormwater pollution.</p> <ul style="list-style-type: none"> • Where landscaped areas are used to retain or detain stormwater, specify plants that are tolerant of saturated soil conditions. • Consider using pest-resistant plants, especially adjacent to hardscape. • To ensure successful establishment, select plants appropriate to site soils, slopes, climate, sun, wind, rain, land use, air movement, ecological consistence, and plant interactions. 	<ul style="list-style-type: none"> • Provide integrated Pest Management information to new owners, lessees, and operators
Refuse Areas	<ul style="list-style-type: none"> • Trash receptacles shall be emptied by trained personnel on a regular basis to maintain clean facilities • Trash enclosures area shall be kept clean by sweeping on a regular basis. • Trash enclosures shall be emptied by a qualified, contracted waste management company or the City of Riverside. • Signs will be posted on or near dumpsters with the words, "Do not dump hazardous materials here" or similar. 	<ul style="list-style-type: none"> • Provide adequate number of receptacles • Inspect receptacles regularly, and repair or replace leaky receptacles • Keep receptacles covered • Prohibit/prevent dumping of liquid or hazardous wastes • Post "No Hazardous Materials signs" • Inspect and pick up litter daily and clean up spills immediately • Keep spill control materials on-site
Condensate Drain Lines	<ul style="list-style-type: none"> • Condensate lines for equipment get drained into the sanitary sewer at the mop sink. 	
Plazas, sidewalks, loading docks and parking lots		<p>Sweep plazas, sidewalks, and parking lots regularly to prevent accumulation of litter and debris. Collect debris from pressure</p>

		washing to prevent entry into the storm drain system. Collect washwater containing and cleaning agent or degreaser and discharge to the sanitary sewer, not to a storm drain.

Section H: Construction Plan Checklist

Table H.1 Construction Plan Cross-reference

BMP No. or ID	BMP Identifier and Description	Corresponding Plan Sheet(s)	BMP Location (Lat/Long)
BMP 1	Underground Bioretention with Underdrain		
BMP 2	Underground Bioretention with Underdrain		

Section I: Operation, Maintenance and Funding

The Co-Permittee will periodically verify that Stormwater BMPs on your site are maintained and continue to operate as designed. To make this possible, your Co-Permittee will require that you include in Appendix 9 of this Project-Specific WQMP:

1. A means to finance and implement facility maintenance in perpetuity, including replacement cost.
2. Acceptance of responsibility for maintenance from the time the BMPs are constructed until responsibility for operation and maintenance is legally transferred. A warranty covering a period following construction may also be required.
3. An outline of general maintenance requirements for the Stormwater BMPs you have selected.
4. Figures delineating and designating pervious and impervious areas, location, and type of Stormwater BMP, and tables of pervious and impervious areas served by each facility. Geo-locating the BMPs using a coordinate system of latitude and longitude is recommended to help facilitate a future statewide database system.
5. A separate list and location of self-retaining areas or areas addressed by LID Principles that do not require specialized O&M or inspections but will require typical landscape maintenance as noted in Chapter 5, pages 85-86, in the WQMP Guidance. Include a brief description of typical landscape maintenance for these areas.

Your local Co-Permittee will also require that you prepare and submit a detailed Stormwater BMP Operation and Maintenance Plan that sets forth a maintenance schedule for each of the Stormwater BMPs built on your site. An agreement assigning responsibility for maintenance and providing for inspections and certification may also be required.

Details of these requirements and instructions for preparing a Stormwater BMP Operation and Maintenance Plan are in Chapter 5 of the WQMP Guidance Document.

Maintenance Mechanism: Facility maintenance is self-funded as part of continuing business operations. Employee shall perform maintenance duties as part of their job requirements except for specialized or contracted services to be provided by qualified personnel.

Will the proposed BMPs be maintained by a Home Owners' Association (HOA) or Property Owners Association (POA)?

Y N

Operation and Maintenance Plan and Maintenance Mechanism is included in Appendix 9. Educational materials for those personnel that will be maintaining the proposed BMPs within this Project-Specific WQMP are included in Appendix 10.

Appendix 1: Maps and Site Plans

Location Map, WQMP Site Plan and Receiving Waters Map

Exhibit A Location Map

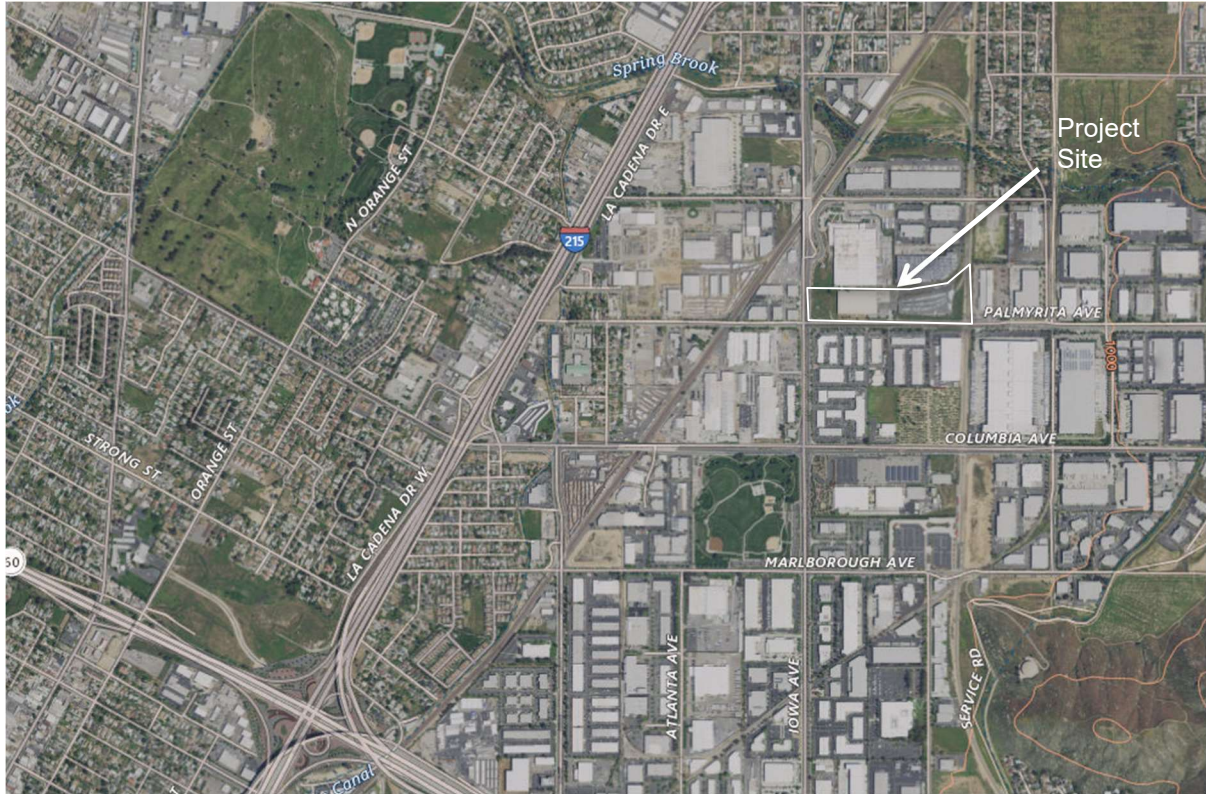

Source: USGS

PWQMP PLAN

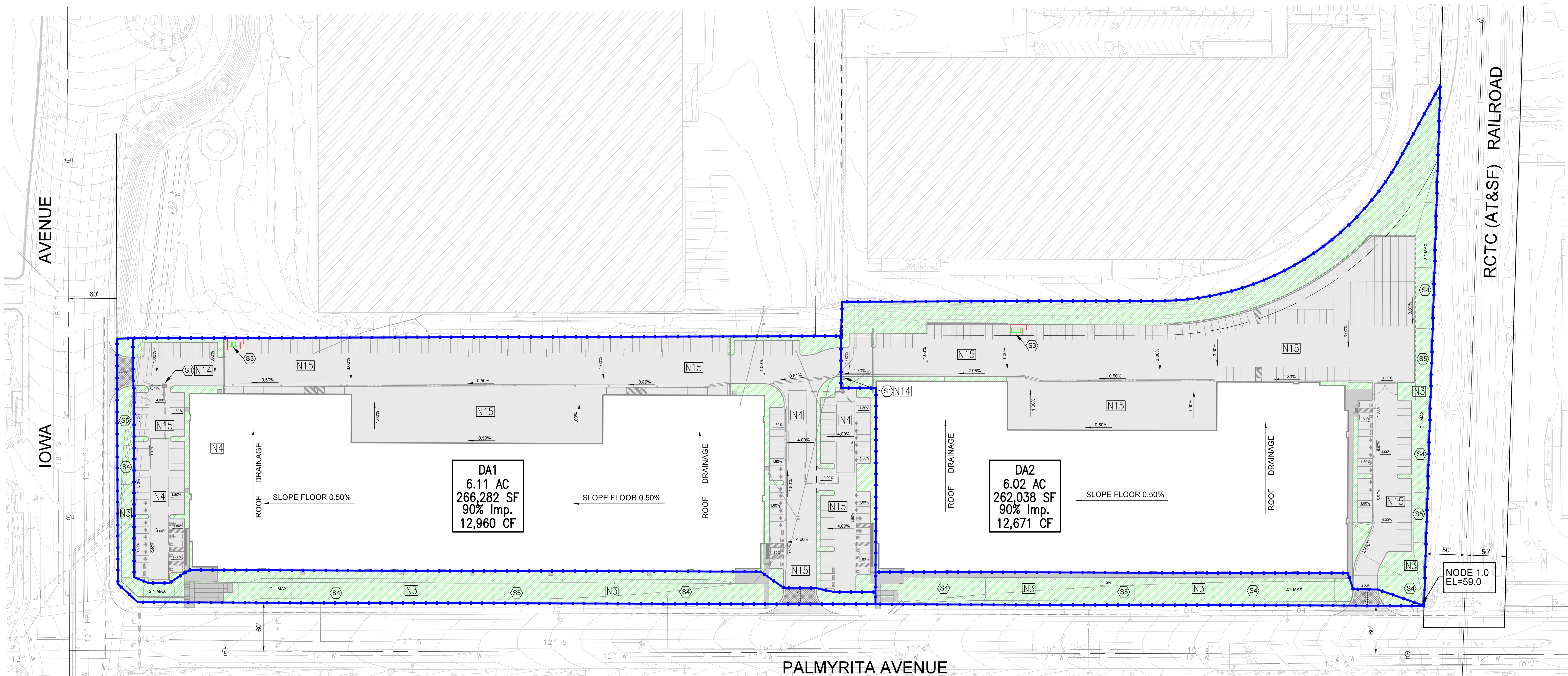

DA1
6.11 AC
266,282 SF
90% Imp.
12,960 CF

DA2
6.02 AC
262,038 SF
90% Imp.
12,671 CF

NODE 1.0
EL=59.0

STRUCTURAL SOURCE CONTROL BMPs

- S1 STORM DRAIN STENCILING
- S3 TRASH STORAGE AREAS, SD-32
- S4 EFFICIENT IRRIGATION, SD-12 TYPICAL ALL LANDSCAPING
- S5 FG OF LANDSCAPE AREAS A MINIMUM OF 1" TO 2" BELOW TC, SIDEWALK, OR PAVEMENT. TYPICAL ALL LANDSCAPE AREAS.

NON-STRUCTURAL SOURCE CONTROL BMPs

- N1 - EDUCATION
- N2 - ACTIVITY RESTRICTIONS
- N3 - LANDSCAPE MANAGEMENT
- N4 - BMP MAINTENANCE
- N6 - LOCAL WATER QUALITY ORDINANCES
- N7 - SPILL CONTINGENCY PLAN
- N8 - UNDERGROUND STORAGE TANK COMPLIANCE
- N9 - HAZARDOUS MATERIALS DISCLOSURE COMPLIANCE
- N10 - UNIFORM FIRE CODE IMPLEMENTATION
- N11 - LITTER/DEBRIS CONTROL PROGRAM
- N12 - EMPLOYEE TRAINING
- N14 - CATCH BASIN INSPECTION PROGRAM
- N15 - VACUUM SWEEPING OF PARKING LOT
- N17 - COMPLIANCE WITH ALL OTHER APPLICABLE NPDES STANDARDS

LID BMP SUMMARY

- DA1
 - 266,282 SF / 90% IMPERVIOUS
 - DCV = 12,960 CF
 - PROVIDE 68 MC-3500 CHAMBERS
 - V-PROVIDED = 13,202 CF
- DA2
 - 262,038 SF / 90% IMPERVIOUS
 - DCV = 12,671 CF
 - PROVIDE 68 MC-3500 CHAMBERS
 - V-PROVIDED = 13,202 CF

LEGEND

DRAINAGE AREA DATA

DAX/DMA X	DRAINAGE AREA
X.XX AC	DMA AREA (ACRES)
XX,XXX SF	DMA AREA (SF)
90% Imp.	DMA PERCENT IMPERVIOUS
XX,XXX CF	DMA TREATMENT VOLUME (Vbmp)

---|---|--- DRAINAGE AREA (DA) BOUNDARY

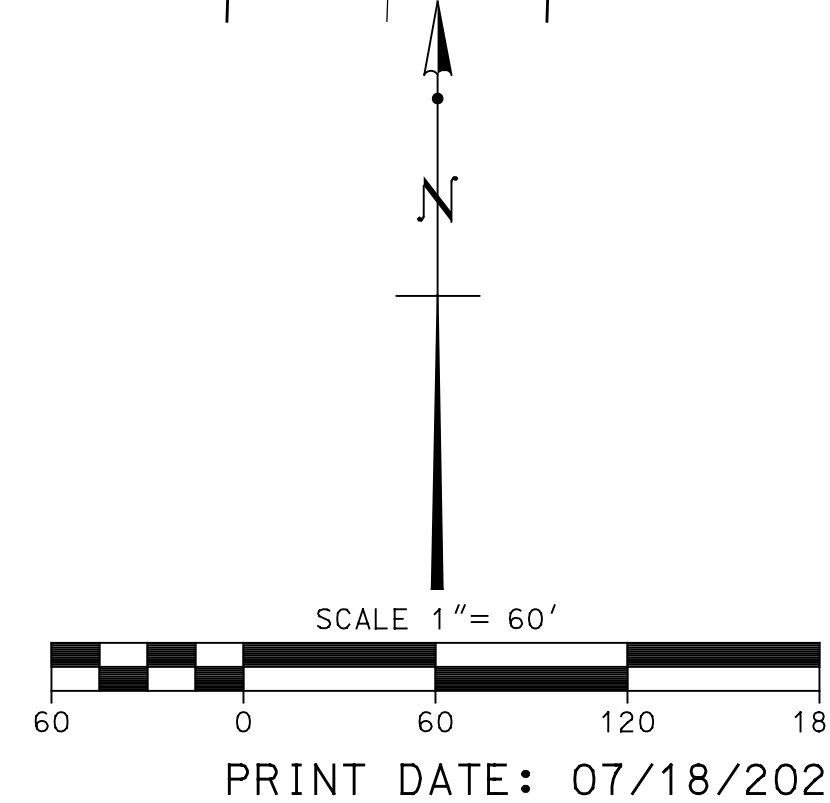
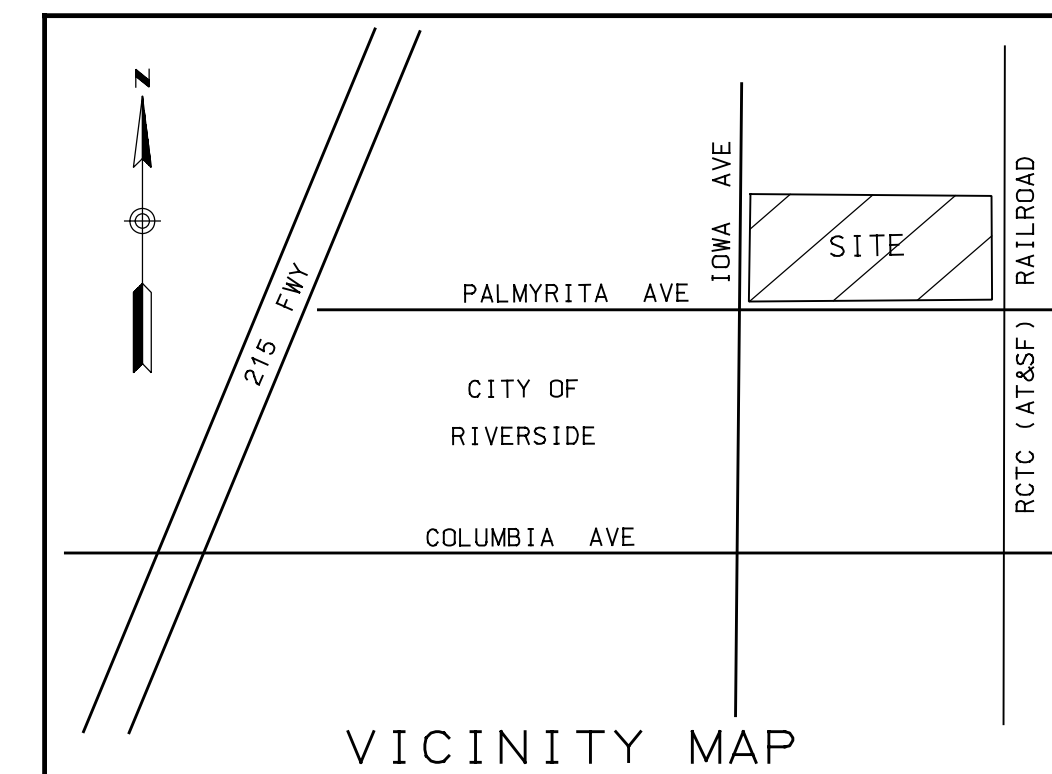

Underground Service Alert



Call: TOLL FREE

1-800-277-8000

TWO WORKING DAYS BEFORE YOU DIG



Goodman & Associates
2079 SKY VIEW DRIVE
COLTON, CA 92324
(909) 824-2775

DOUGLAS L. GOODMAN DATE
RCE 28500, 3-31-2024

MARK	REVISIONS	APPR.	DATE

DESIGNED BY _____ DRAWN BY _____ CHECKED BY _____

CITY OF RIVERSIDE

PLANNING DEPARTMENT

APPROVAL _____ DATE _____

PRELIMINARY WATER QUALITY MANAGEMENT PLAN

PREPARED FOR DEDEAUX PROPERTIES

1151 PALMYRITA AVENUE

APN: 247-170-030 & 247-170-039

SCALE:
AS SHOWN

SHEET 1 OF
1 SHEETS

Appendix 2: Construction Plans

Grading and Drainage Plans

Appendix 3: Soils Information

Geotechnical Study and Other Infiltration Testing Data



Sladden Engineering

45090 Golf Center Parkway, Suite F, Indio, CA. 92201 (760) 863-0713 Fax (760) 863-0847
6782 Stanton Avenue, Suite C, Buena Park, CA. 90621 (714) 523-0952 Fax (714) 523-1369
450 Egan Avenue, Beaumont, CA. 92223 (951) 845-7743 Fax (951) 845-8863
www.sladdenengineering.com

June 14, 2022

Project No. 644-22043
22-06-082

Dedeaux Properties
100 Wilshire Boulevard, Suite 250
Santa Monica, California 90401

Project: Proposed Industrial/Warehouse Buildings
NEC Iowa Avenue and Palmyrita Avenue
APN 247-170-030 & 039
Riverside, California

Subject: Percolation/Infiltration Testing for On-Site Stormwater Management

Ref: Geotechnical Investigation, Proposed Industrial/Warehouse Building, NEC Iowa Avenue and Palmyrita Avenue, Riverside, California; prepared by Sladden Engineering, Project No 644-22043, Report No. 22-06-081, dated June 13, 2022.

In accordance with your request, we have performed percolation testing on the subject site to evaluate the infiltration potential of the near surface soil to assist in stormwater management system design. It is our understanding that on-site stormwater retention including infiltration is proposed for the project.

Percolation testing was performed on May 3, 2022, within two (2) shallow tests bores excavated on the site. Testing was performed at depths of approximately 5.00 and 10.00 feet below existing grade. The approximate locations of the test holes are presented on the attached Exploration Location Plan (Figure 3). Testing was performed by placing water within the test holes and recording the drop in the water surface with time. Testing was performed in general accordance with the *United States Bureau of Reclamation (BOR) Procedure 7300-89 (1999)*. Test results are summarized in the following table.

PERCOLATION TEST RESULTS

Test No.	Depth (Ft)	USCS	Percolation Rate (in/hr)	Infiltration Rate (in/hr)
P-1	5.00	SC	6.25	0.61
P-2	10.00	SC	10.00	1.03

The percolation rates determined represent the ultimate field rates that do not include a safety factor. The corresponding infiltration rates were calculated using the Porchet Method.

Based on our field investigation and our review of groundwater levels¹ within the vicinity, it is our professional opinion that groundwater should not be a controlling factor in on-site stormwater retention/infiltration system design.

If you have any questions regarding this memo or the testing summarized herein, please contact the undersigned.

Respectfully submitted,
SLADDEN ENGINEERING

Matthew J. Cohrt
Principal Geologist

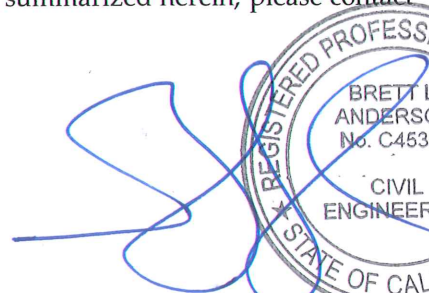

Brett L. Anderson
Principal Engineer



Copies: 4/Addressee

¹ California Department of Water Resources (CDWR), 2022, Historical Data by Well-Map Interface, available at: <http://wdl.water.ca.gov/waterdatalibrary/Home.aspx>

SITE LOCATION MAP
REGIONAL GEOLOGIC MAP
EXPLORATION LOCATION PLAN



USGS (2015)



Sladden Engineering

SITE LOCATION MAP

Project Number:	644-22043
Report Number:	22-06-082
Date:	June 14, 2022

FIGURE

1

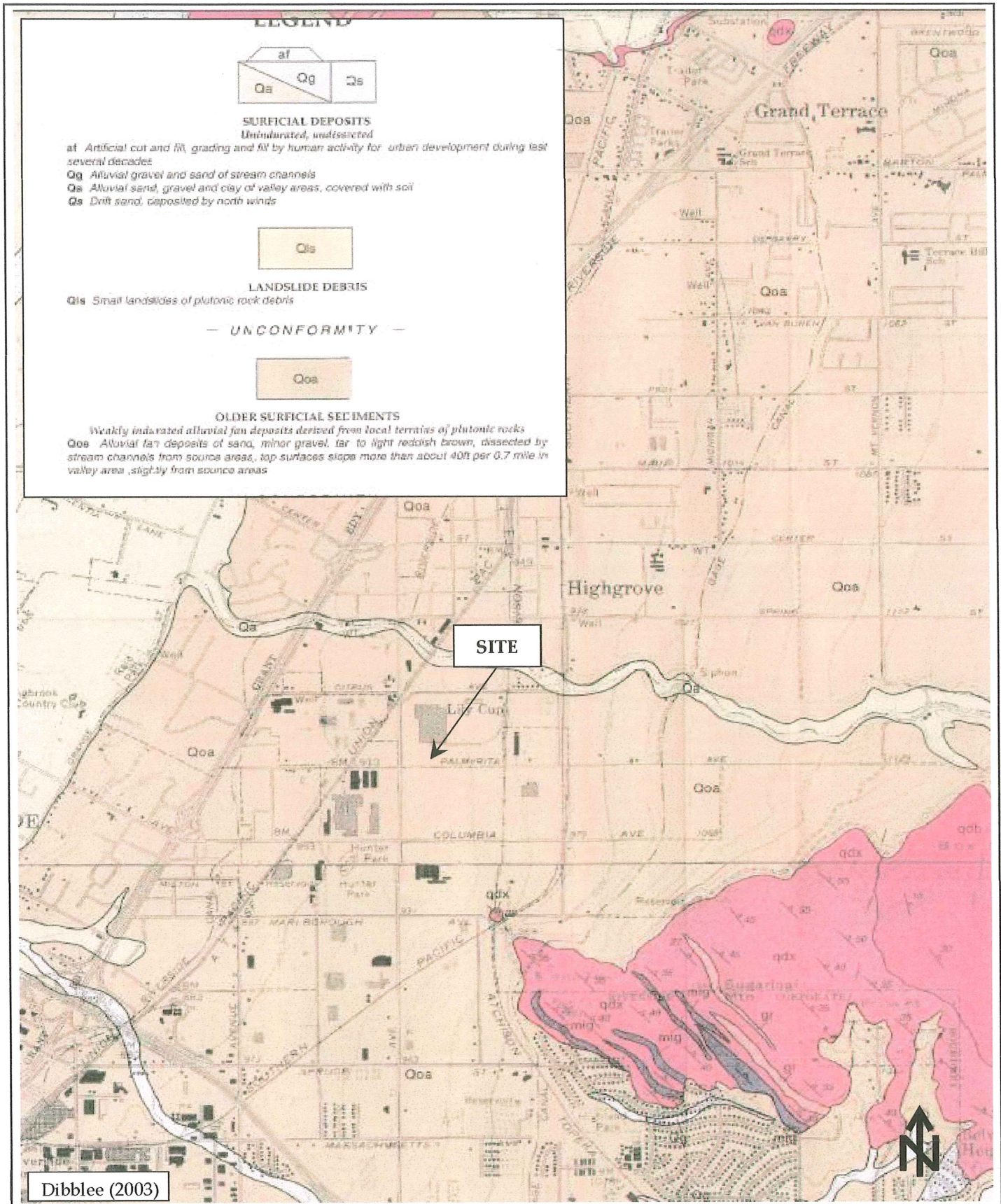

REGIONAL GEOLOGIC MAP

FIGURE

Project Number:

644-22043

Report Number:

22-06-082

Date:

June 14, 2022

2



Sladden Engineering

LEGEND

⊕ BH-4 (P-2) Borehole Location (Percolation Test Hole)

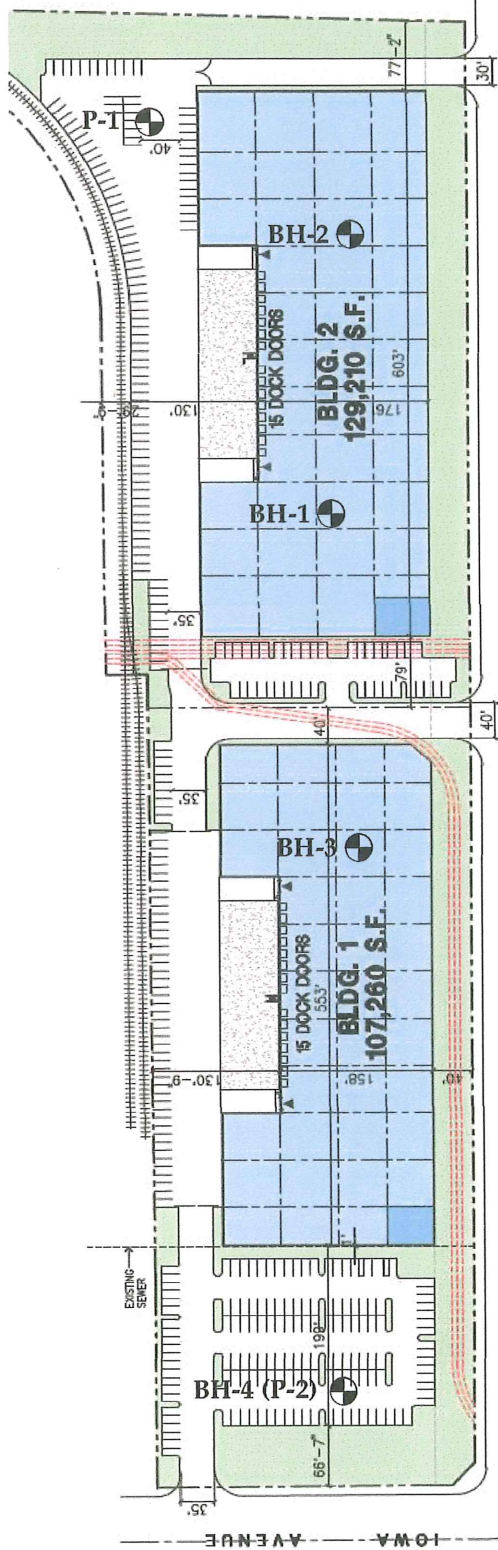

AVENUE

PALMYRITA

Legend

- POTENTIAL OFFICE WITH 2ND FLOOR
- WAREHOUSE
- DRIVE THRU DOOR

Aerial Map



Note: This is a conceptual plan. It is based on preliminary information which is not fully verified and may be incomplete. It is meant as a comparative aid in examining alternate development strategies and any quantities indicated are subject to revision as more reliable information becomes available.



Conceptual Site Plan

Iowa Avenue. & Palmyrita Avenue.



Calculation

	BLDG. 1	BLDG. 2	TOTAL	ZONING ORDINANCE FOR CITY:
EA	242,138	310,303	552,441 s.f.	BMP - Business and Manufacturing Park Zone
F	6.48	7.12	13.60 ac	MAXIMUM BUILDING HEIGHT ALLOWED
CLAREA	2,500	2,500	5,000 s.f.	Height - 40'
- 1st Floor	2,500	2,500	5,000 s.f.	Variance - 11'
- 2nd Floor	102,250	129,210	231,460 s.f.	Actual - 56' Max.
USE	38.0%	41.6%	39.5%	FAR - 1.50
LANDSCAPE REQUIRED				Percentage - 5% of parking lot area
10250 s.f.	20	20	40 stalls	LANDSCAPE PROVIDED
11,000 s.f.	102	124	226 stalls	Percentage
				63,227
				62,944
				124,171 s.f.
				SETBACK
	132	144	276 stalls	Front - 40' (BLDG over 30), 20' (BLDG 30' or less)
				Side/Rear - 0'
	204	144	348 stalls	Landscape - 10' (20 or fewer parking spaces)
				Landscape - 35' (21 or greater parking spaces)

EXPLORATION LOCATION PLAN

FIGURE

Project Number:

644-22043

Report Number:

22-06-082

Date:

June 14, 2022

3



Sladden Engineering

BORELOGS



Sladden Engineering

BORE LOG

Equipment:	Mobile B-61	Date Drilled:	4/19/2022
Elevation:	935 Ft. MSL	Boring No:	BH-1

Sample	Blow Counts	Bulk Sample	Expansion Index	% Minus #200	% Moisture	Density, pcf	Depth (Feet)	Graphic Lithology	Description
							0		3.25 inches AC
	6 10 15	1	20	44.2	9.5	127.8	2		Silty Sand (SM); yellowish brown, dry to slightly moist, fine- to coarse-grained with gravel (Fill).
	13 13 17			50.1	8.4	129.0	4		Sandy Clay (CL); dark grayish brown, dry, very stiff, low plasticity with gravel (Qoa).
							6		
	8 9 8			28.3	5.0		10		Clayey Sand (SC); light yellowish brown, dry, medium dense, fine- to coarse-grained with gravel; micaceous (Qoa).
	24 50-4			27.1	9.1	117.6	16		Clayey Sand (SC); light yellowish brown, dry, very dense, fine- to coarse-grained (Qoa).
	12 17 19			15.6	4.4		20		Silty Sand (SM); yellowish brown, dry, dense, fine- to coarse-grained (Qoa).
	21 50-6			43.0	10.5	126.6	26		Silty Sand (SM); yellowish brown, dry to slightly moist, very dense, fine- to coarse-grained (Qoa).
	20 27 035			31.3	7.2		30		Clayey Sand (SC); light yellowish brown, dry, very dense, fine- to coarse-grained Qoa.
	27 50-6			27.6	6.7	123.1	36		Clayey Sand (SC); yellowish brown, dry, very dense, fine- to coarse-grained (Qoa).
	14 25 47			41.6	9.4		40		Clayey Sand (SC); yellowish brown, dry to slightly moist, very dense, fine- to coarse-grained, micaceous (Qoa).
	14 16 26			42.7	11.8	122.8	46		Clayey Sand (SC); yellowish brown, slightly moist, medium dense, fine- to coarse-grained, micaceous (Qoa).
	18 38 46			35.7	7.5		50		Clayey Sand (SC); yellowish brown, slightly moist, very dense, fine- to coarse-grained (Qoa).

Completion Notes:
 Terminated at 51.5 Feet bgs.
 No Bedrock Encountered.
 No Groundwater or Seepage Encountered.

PROPOSED INDUSTRIAL/WAREHOUSE BUILDINGS
 NEC IOWA AVENUE AND PALMYRITA AVENUE, RIVERSIDE
 Project No: 644-22043
 Report No: 22-06-082



Sladden Engineering

BORE LOG

Equipment:	Mobile B-61	Date Drilled:	4/19/2022
Elevation:	935 Ft. MSL	Boring No:	BH-2

Sample	Blow Counts	Bulk Sample	Expansion Index	% Minus #200	% Moisture	Density, pcf	Depth (Feet)	Graphic Lithology	Description
							0	3.50 inches AC	
							2		Silty Sand (SM); yellowish brown, dry to slightly moist, fine- to coarse-grained with gravel (Fill).
							4		Clayey Sand (SC); dark yellowish brown, slightly moist, medium dense, fine- to coarse-grained, micaceous (Qoa).
	7 12 13			49.2	12.3	6			
						8			
							10		Clayey Sand (SC); dark yellowish brown, slightly moist, very dense, fine- to coarse-grained, micaceous (Qoa).
	19 50-6			49.6	9.7	12			
							14		Clayey Sand (SC); dark yellowish brown, slightly moist, very dense, fine- to coarse-grained, micaceous (Qoa).
	20 33 50			21.7	6.9	16			
							18		Clayey Sand (SC); dark yellowish brown, slightly moist, very dense, fine- to coarse-grained, micaceous (Qoa).
						20			
	12 26 50			21.6	7.0	22			
							24		Terminated at ~21.5 Feet bgs.
							26		No Bedrock Encountered.
							28		No Groundwater or Seepage Encountered.
							30		
							32		
							34		
							36		
							38		
							40		
							42		
							44		
							46		
							48		
							50		

Completion Notes:

PROPOSED INDUSTRIAL/WAREHOUSE BUILDINGS
NEC IOWA AVENUE AND PALMYRITA AVENUE, RIVERSIDE

Project No:	644-22043
Report No:	22-06-082



Sladden Engineering

BORE LOG

Equipment:	Mobile B-61	Date Drilled:	4/19/2022
Elevation:	935 Ft. MSL	Boring No:	BH-3

Sample	Blow Counts	Bulk Sample	Expansion Index	% Minus #200	% Moisture	Density, pcf	Depth (Feet)	Graphic Lithology	Description
							0		3.25 inches AC/4.00 inches Base Material
							2		Silty Sand (SM); yellowish brown, dry to slightly moist, fine- to coarse-grained with gravel (Fill).
	14 24 45			37.0	10.5	124.4	4		Clayey Sand (SC); light yellowish brown, slightly moist, dense, fine- to coarse-grained with gravel, micaceous (Qoa).
							6		
	3 4 5			6.6	2.4		10		Sand (SW); yellowish brown, dry, loose, fine- to coarse-grained with gravel (Qoa).
							12		Clayey Sand (SC); light yellowish brown, slightly moist, dense, fine- to coarse-grained with gravel, micaceous (Qoa).
	12 28 44			38.1	9.3	126.7	14		
	50-6			20.9	7.2		16		Clayey Sand (SC); light yellowish brown, slightly moist, very dense, fine- to coarse-grained with gravel, micaceous (Qoa).
							18		Terminated at ~20.5 Feet bgs. No Bedrock Encountered. No Groundwater or Seepage Encountered.
							20		
							22		
							24		
							26		
							28		
							30		
							32		
							34		
							36		
							38		
							40		
							42		
							44		
							46		
							48		
							50		

Completion Notes:

PROPOSED INDUSTRIAL/WAREHOUSE BUILDINGS
 NEC IOWA AVENUE AND PALMYRITA AVENUE, RIVERSIDE

Project No:	644-22043	Page	3
Report No:	22-06-082		



Sladden Engineering

BORE LOG

Equipment:	Mobile B-61	Date Drilled:	4/19/2022
Elevation:	935 Ft. MSL	Boring No:	BH-4/P-2

Sample	Blow Counts	Bulk Sample	Expansion Index	% Minus #200	% Moisture	Density, pcf	Depth (Feet)	Graphic Lithology	Description
							2		Silty Sand (SM) to Clayey Sand (SC); yellowish brown, dry to slightly moist, fine- to coarse-grained with gravel (Fill).
	15 24 28			60.4	13.8		4		Sandy Silt (ML); yellowish brown, moist, hard, low plasticity (Qoa).
							6		
	14 19 30			48.6	10.9	128.4	10		Clayey Sand (SC); yellowish brown, slightly moist, dense, fine- to coarse-grained, micaceous (Qoa).
							12		Terminated at 11.5 Feet bgs. No Bedrock Encountered. No Groundwater or Seepage Encountered.
							14		
							16		
							18		
							20		
							22		
							24		
							26		
							28		
							30		
							32		
							34		
							36		
							38		
							40		
							42		
							44		
							46		
							48		
							50		

Completion Notes:

PROPOSED INDUSTRIAL/WAREHOUSE BUILDINGS
NEC IOWA AVENUE AND PALMYRITA AVENUE, RIVERSIDE

Project No:	644-22043
Report No:	22-06-082



Sladden Engineering

BORE LOG

Equipment:	Mobile B-61	Date Drilled:	4/19/2022
Elevation:	935 Ft. MSL	Boring No:	P-1

Sample	Blow Counts	Bulk Sample	Expansion Index	% Minus #200	% Moisture	Density, pcf	Depth (Feet)	Graphic Lithology	Description
							2		Silty Sand (SM) to Clayey Sand (SC); yellowish brown, dry to slightly moist, fine- to coarse-grained with gravel (Fill).
							4		Clayey Sand (SC); yellowish brown, slightly moist, dense, fine- to coarse-grained, micaceous (Qoa).
							6		Terminated at ~5.00 Feet bgs. No Bedrock Encountered. No Groundwater or Seepage Encountered.
							8		
							10		
							12		
							14		
							16		
							18		
							20		
							22		
							24		
							26		
							28		
							30		
							32		
							34		
							36		
							38		
							40		
							42		
							44		
							46		
							48		
							50		

Completion Notes:

PROPOSED INDUSTRIAL/WAREHOUSE BUILDINGS
NEC IOWA AVENUE AND PALMYRITA AVENUE, RIVERSIDE

Project No: 644-22043

Report No: 22-06-082

PERCOLATION/INFILTRATION TEST DATA SHEETS

STORMWATER PERCOLATION SHEET (LESS THAN 10 FT)

Project:	NEC Iowa Ave and Palmyrita	Depth (ft):	5.00
Job No. :	644-22043	USCS Soil Class:	SC
Date:	5/3/2022	Sandy Soil:	R.O.
Test Hole #:	P-1	Tested By:	R.O.

READING	TIME (min)	DEPTH (ft)	INITIAL W (in)	FINAL W (in)	ΔW (in)	IN/HR
A	25.00	5.00	20	19	1	2.40
B	25.00	5.00	20	18.5	1 4/8	3.60

READING	TIME (min)	DEPTH (ft)	INITIAL W (in)	FINAL W (in)	ΔW (in)	IN/HR
1	30.00	5.00	20	15 2/8	4 6/8	9.5
2	30.00	5.00	20	16 1/8	3 7/8	7.75
3	30.00	5.00	20	16 1/8	3 7/8	7.75
4	30.00	5.00	20	16 6/8	3 2/8	6.5
5	30.00	5.00	20	16 2/8	3 6/8	7.5
6	30.00	5.00	20	16 3/8	3 5/8	7.25
7	30.00	5.00	20	16 5/8	3 3/8	6.75
8	30.00	5.00	20	16 6/8	3 2/8	6.5
9	30.00	5.00	20	16 5/8	3 3/8	6.75
10	30.00	5.00	20	16 7/8	3 1/8	6.25
11	30.00	5.00	20	16 7/8	3 1/8	6.25

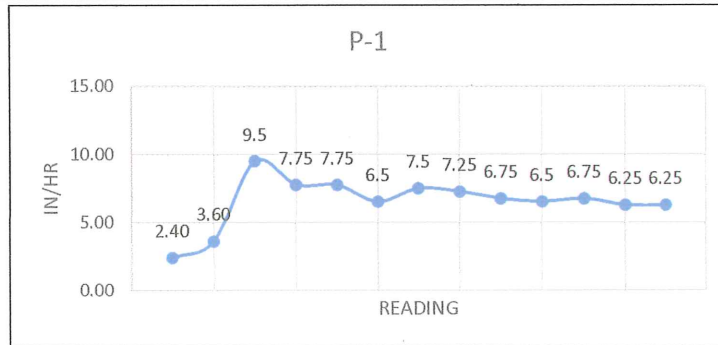

PERCOLATION RATE CONVERSION (PORCHET METHOD)

$I_t =$	$\frac{\Delta H \ 60 \ R}{\Delta t(r+2H_{avg})}$	Δt (minutes)
$\Delta t =$	30.00	D_f (Final Depth to water)
$D_f =$	43.13	r (hole radius in inches)
$r =$	4.00	D_0 (Initial Depth to water)
$D_0 =$	40	D_t (Total Depth of test hole)
$D_t =$	60.00	H_0 (initial height of water at selected time interval)
$H_0 =$	20	$H_0 = D_t - D_0$
$H_f =$	16.875	H_f (final height of water at the selected time interval)
$\Delta H =$	3.13	$H_f = D_t - D_f$
$H_{avg} =$	18.44	ΔH (change in head over the time interval)
		$\Delta H = H_0 - H_f$
		H_{avg} (average head height over the time interval)
		$H_{avg} = (H_0 + H_f) / 2$

Field Rate: 6.25 in/hr
 Infiltration Rate: 0.61 in/hr

STORMWATER PERCOLATION SHEET (LESS THAN 10 FT)

Project:	NEC Iowa Ave and Palmyrita	Depth (ft):	10.00
Job No. :	644-22043	USCS Soil Class:	SC
Date:	5/3/2022	Sandy Soil:	R.O.
Test Hole #:	P-1	Tested By:	R.O.

READING	TIME (min)	DEPTH (ft)	INITIAL W (in)	FINAL W (in)	ΔW (in)	IN/HR
A	25.00	10.00	20	14 4/8	5 4/8	13.20
B	25.00	10.00	20	14 1/8	5 7/8	14.10

READING	TIME (min)	DEPTH (ft)	INITIAL W (in)	FINAL W (in)	ΔW (in)	IN/HR
1	30.00	10.00	20	14 1/8	5 7/8	11.75
2	30.00	10.00	20	14 3/8	5 5/8	11.25
3	30.00	10.00	20	14 4/8	5 4/8	11
4	30.00	10.00	20	14 6/8	5 2/8	10.5
5	30.00	10.00	20	14 6/8	5 2/8	10.5
6	30.00	10.00	20	14 7/8	5 1/8	10.25
7	30.00	10.00	20	14 7/8	5 1/8	10.25
8	30.00	10.00	20	15 1/8	4 7/8	9.75
9	30.00	10.00	20	15	5	10
10	30.00	10.00	20	15 1/8	4 7/8	9.75
11	30.00	10.00	20	15	5	10

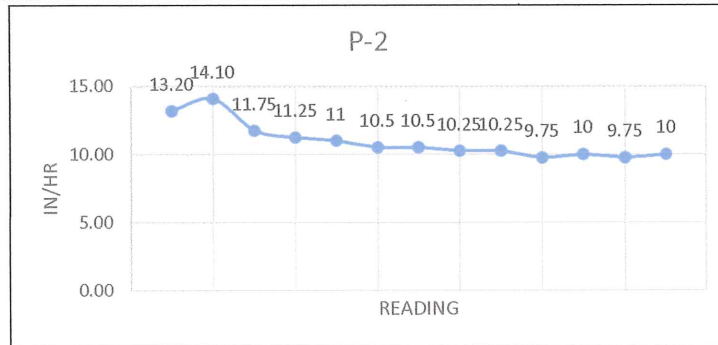

PERCOLATION RATE CONVERSION (PORCHET METHOD)

$I_t = \frac{\Delta H \cdot 60 \cdot R}{\Delta t(r+2H_{avg})}$		Δt (minutes)
		D_f (Final Depth to water)
		r (hole radius in inches)
		D_0 (Initial Depth to water)
$\Delta t =$	30.00	D_t (Total Depth of test hole)
$D_f =$	105.00	H_0 (initial height of water at selected time interval)
$r =$	4.00	$H_0 = D_t - D_0$
$D_0 =$	100	H_f (final height of water at the selected time interval)
$D_t =$	120.00	$H_f = D_t - D_f$
$H_0 =$	20	ΔH (change in head over the time interval)
$H_f =$	15	$\Delta H = H_0 - H_f$
$\Delta H =$	5.00	H_{avg} (average head height over the time interval)
$H_{avg} =$	17.50	$H_{avg} = (H_0 + H_f) / 2$

Field Rate: 10 in/hr
 Infiltration Rate: 1.03 in/hr

Appendix 4: Historical Site Conditions

Phase I Environmental Site Assessment or Other Information on Past Site Use

Not Applicable

Appendix 5: LID Infeasibility

LID Technical Infeasibility Analysis

Not Applicable

Appendix 6: BMP Design Details

BMP Sizing, Design Details and other Supporting Documentation

Santa Ana Watershed - BMP Design Volume, V_{BMP}

(Rev. 10-2011)

Legend:

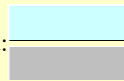

Required Entries

Calculated Cells

*(Note this worksheet shall **only** be used in conjunction with BMP designs from the **LID BMP Design Handbook**)*

Company Name **Goodman and Associates**

Date **7/8/2022**

Designed by **Aaron Skeers**

Case No

Company Project Number/Name **Palmyrita Avenue Warehouses**

BMP Identification

BMP NAME / ID **1**

Must match Name/ID used on BMP Design Calculation Sheet

Design Rainfall Depth

85th Percentile, 24-hour Rainfall Depth,
from the Isohyetal Map in Handbook Appendix E

D_{85} = **0.64** inches

Drainage Management Area Tabulation

Insert additional rows if needed to accommodate all DMAs draining to the BMP

DMA Type/ID	DMA Area (square feet)	Post-Project Surface Type	Effective Imperivous Fraction, I_f	DMA Runoff Factor	DMA Areas x Runoff Factor	Design Storm Depth (in)	Design Capture Volume, V_{BMP} (cubic feet)	Proposed Volume on Plans (cubic feet)
1/A	266,282	Concrete or Asphalt	1	0.89	237523.5			
1/C	39379	Ornamental Landscaping	0.1	0.11	4349.7			
	305661				241873.2	0.64	12960.4	13202

Notes:

Santa Ana Watershed - BMP Design Volume, V_{BMP}

(Rev. 10-2011)

Legend:

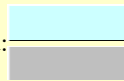

Required Entries

Calculated Cells

*(Note this worksheet shall **only** be used in conjunction with BMP designs from the **LID BMP Design Handbook**)*

Company Name **Goodman and Associates**

Date **7/8/2022**

Designed by **Aaron Skeers**

Case No

Company Project Number/Name **Palmyrita Avenue Warehouses**

BMP Identification

BMP NAME / ID **2**

Must match Name/ID used on BMP Design Calculation Sheet

Design Rainfall Depth

85th Percentile, 24-hour Rainfall Depth,
from the Isohyetal Map in Handbook Appendix E

D_{85} = **0.64** inches

Drainage Management Area Tabulation

Insert additional rows if needed to accommodate all DMAs draining to the BMP

DMA Type/ID	DMA Area (square feet)	Post-Project Surface Type	Effective Imperivous Fraction, I_f	DMA Runoff Factor	DMA Areas x Runoff Factor	Design Storm Depth (in)	Design Capture Volume, V_{BMP} (cubic feet)	Proposed Volume on Plans (cubic feet)
2/B	262,039	Concrete or Asphalt	1	0.89	233738.8			
2/D	24,747	Ornamental Landscaping	0.1	0.11	2733.5			
	286786				236472.3	0.64	12671	13202

Notes:

User Inputs

Chamber Model:	MC-3500
Outlet Control Structure:	Yes
Project Name:	Palmyrita Avenue Warehouses no.1
Engineer:	Aaron Skeers
Project Location:	California
Measurement Type:	Imperial
Required Storage Volume:	12961 cubic ft.
Stone Porosity:	40%
Stone Foundation Depth:	9 in.
Stone Above Chambers:	12 in.
Average Cover Over Chambers:	18 in.
Design Constraint Dimensions:	(26 ft. x 190 ft.)

Results

System Volume and Bed Size

Installed Storage Volume:	13202.01 cubic ft.
Storage Volume Per Chamber:	109.90 cubic ft.
Number Of Chambers Required:	68
Number Of End Caps Required:	6
Chamber Rows:	3
Maximum Length:	174.72 ft.
Maximum Width:	22.85 ft.
Approx. Bed Size Required:	3938.39 square ft.

System Components

Amount Of Stone Required:	522.17 cubic yards
Volume Of Excavation (Not Including Fill):	802.26 cubic yards
Total Non-woven Geotextile Required:	1340.00 square yards
Woven Geotextile Required (excluding Isolator Row):	33.46 square yards
Woven Geotextile Required (Isolator Row):	196.68 square yards
Total Woven Geotextile Required:	230.14 square yards

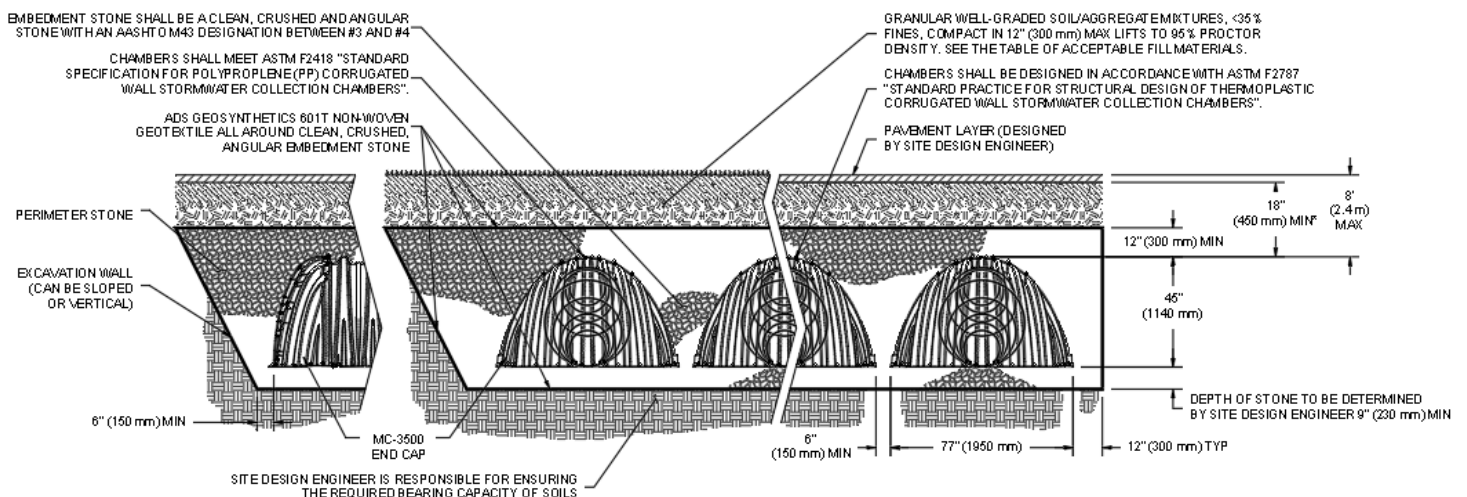

*MINIMUM COVER TO BOTTOM OF FLEXIBLE PAVEMENT. FOR UNPAVED INSTALLATIONS WHERE RUTTING FROM VEHICLES MAY OCCUR, INCREASE COVER TO 24"



NOAA Atlas 14, Volume 6, Version 2
Location name: Riverside, California, USA*
Latitude: 34.0055°, Longitude: -117.338°
Elevation: 932.58 ft**



* source: ESRI Maps
 ** source: USGS

POINT PRECIPITATION FREQUENCY ESTIMATES

Sanja Perica, Sarah Dietz, Sarah Heim, Lillian Hiner, Kazungu Maitaria, Deborah Martin, Sandra Pavlovic, Ishani Roy, Carl Tryppaluk, Dale Unruh, Fenglin Yan, Michael Yekta, Tan Zhao, Geoffrey Bonnin, Daniel Brewer, Li-Chuan Chen, Tye Parzybok, John Yarchoan

NOAA, National Weather Service, Silver Spring, Maryland

[PF_tabular](#) | [PF_graphical](#) | [Maps_&_aerials](#)

PF tabular

PDS-based point precipitation frequency estimates with 90% confidence intervals (in inches)¹										
Duration	Average recurrence interval (years)									
	1	2	5	10	25	50	100	200	500	1000
5-min	0.090 (0.075-0.109)	0.115 (0.096-0.140)	0.149 (0.124-0.181)	0.177 (0.146-0.217)	0.216 (0.171-0.274)	0.246 (0.191-0.319)	0.277 (0.210-0.368)	0.309 (0.228-0.424)	0.354 (0.250-0.506)	0.389 (0.265-0.576)
10-min	0.128 (0.107-0.156)	0.165 (0.137-0.200)	0.213 (0.177-0.260)	0.254 (0.209-0.311)	0.309 (0.246-0.392)	0.352 (0.274-0.457)	0.397 (0.301-0.528)	0.443 (0.327-0.607)	0.507 (0.358-0.725)	0.557 (0.380-0.826)
15-min	0.155 (0.130-0.188)	0.199 (0.166-0.242)	0.258 (0.214-0.314)	0.307 (0.253-0.376)	0.374 (0.297-0.475)	0.426 (0.331-0.553)	0.480 (0.364-0.639)	0.536 (0.395-0.734)	0.613 (0.433-0.877)	0.674 (0.459-0.999)
30-min	0.235 (0.196-0.285)	0.302 (0.251-0.366)	0.391 (0.324-0.475)	0.464 (0.382-0.569)	0.565 (0.450-0.718)	0.644 (0.502-0.836)	0.726 (0.551-0.966)	0.811 (0.598-1.11)	0.928 (0.655-1.33)	1.02 (0.695-1.51)
60-min	0.344 (0.287-0.417)	0.442 (0.368-0.536)	0.572 (0.475-0.696)	0.680 (0.560-0.834)	0.828 (0.659-1.05)	0.944 (0.735-1.23)	1.06 (0.807-1.42)	1.19 (0.875-1.63)	1.36 (0.959-1.94)	1.49 (1.02-2.21)
2-hr	0.491 (0.410-0.595)	0.627 (0.522-0.760)	0.806 (0.669-0.980)	0.953 (0.784-1.17)	1.15 (0.918-1.47)	1.31 (1.02-1.70)	1.47 (1.12-1.96)	1.64 (1.21-2.24)	1.86 (1.32-2.67)	2.04 (1.39-3.03)
3-hr	0.601 (0.501-0.728)	0.764 (0.637-0.927)	0.981 (0.814-1.19)	1.16 (0.953-1.42)	1.40 (1.11-1.78)	1.59 (1.24-2.06)	1.78 (1.35-2.37)	1.98 (1.46-2.71)	2.25 (1.59-3.22)	2.46 (1.68-3.65)
6-hr	0.836 (0.697-1.01)	1.07 (0.887-1.29)	1.37 (1.13-1.66)	1.61 (1.33-1.98)	1.95 (1.55-2.47)	2.20 (1.71-2.86)	2.46 (1.87-3.28)	2.73 (2.02-3.75)	3.10 (2.19-4.44)	3.39 (2.31-5.02)
12-hr	1.11 (0.921-1.34)	1.42 (1.18-1.72)	1.82 (1.51-2.22)	2.15 (1.77-2.64)	2.60 (2.07-3.30)	2.94 (2.29-3.82)	3.29 (2.50-4.38)	3.65 (2.69-5.00)	4.13 (2.92-5.91)	4.51 (3.07-6.68)
24-hr	1.47 (1.30-1.69)	1.90 (1.68-2.19)	2.46 (2.17-2.84)	2.91 (2.55-3.40)	3.53 (2.99-4.25)	4.00 (3.32-4.92)	4.48 (3.63-5.64)	4.97 (3.92-6.43)	5.63 (4.26-7.59)	6.14 (4.49-8.56)
2-day	1.79 (1.58-2.06)	2.35 (2.08-2.71)	3.09 (2.72-3.57)	3.69 (3.23-4.30)	4.51 (3.82-5.43)	5.13 (4.26-6.31)	5.77 (4.67-7.27)	6.43 (5.07-8.32)	7.31 (5.54-9.86)	8.00 (5.86-11.2)
3-day	1.91 (1.69-2.20)	2.56 (2.26-2.95)	3.40 (3.00-3.94)	4.10 (3.59-4.78)	5.05 (4.28-6.09)	5.79 (4.80-7.12)	6.54 (5.30-8.24)	7.32 (5.77-9.47)	8.38 (6.34-11.3)	9.20 (6.73-12.8)
4-day	2.05 (1.82-2.37)	2.77 (2.45-3.20)	3.73 (3.29-4.31)	4.51 (3.95-5.26)	5.59 (4.73-6.73)	6.42 (5.33-7.90)	7.28 (5.89-9.16)	8.16 (6.44-10.6)	9.38 (7.10-12.6)	10.3 (7.56-14.4)
7-day	2.36 (2.09-2.72)	3.22 (2.85-3.72)	4.36 (3.85-5.05)	5.31 (4.64-6.19)	6.60 (5.59-7.96)	7.62 (6.32-9.37)	8.65 (7.01-10.9)	9.73 (7.67-12.6)	11.2 (8.49-15.1)	12.4 (9.06-17.3)
10-day	2.56 (2.27-2.95)	3.51 (3.11-4.06)	4.79 (4.22-5.54)	5.84 (5.11-6.81)	7.29 (6.17-8.79)	8.43 (6.99-10.4)	9.59 (7.77-12.1)	10.8 (8.52-14.0)	12.5 (9.45-16.8)	13.8 (10.1-19.3)
20-day	3.10 (2.75-3.58)	4.30 (3.80-4.96)	5.91 (5.21-6.84)	7.25 (6.34-8.46)	9.12 (7.72-11.0)	10.6 (8.78-13.0)	12.1 (9.81-15.3)	13.7 (10.8-17.8)	15.9 (12.1-21.5)	17.7 (13.0-24.7)
30-day	3.69 (3.26-4.25)	5.11 (4.52-5.90)	7.04 (6.21-8.15)	8.66 (7.57-10.1)	10.9 (9.25-13.2)	12.7 (10.6-15.6)	14.6 (11.8-18.4)	16.6 (13.1-21.5)	19.3 (14.6-26.1)	21.5 (15.7-30.0)
45-day	4.42 (3.91-5.09)	6.10 (5.39-7.04)	8.39 (7.40-9.71)	10.3 (9.03-12.0)	13.0 (11.0-15.7)	15.2 (12.6-18.7)	17.5 (14.2-22.0)	19.9 (15.7-25.8)	23.3 (17.6-31.4)	26.0 (19.0-36.3)
60-day	5.16 (4.57-5.95)	7.08 (6.25-8.16)	9.69 (8.54-11.2)	11.9 (10.4-13.9)	15.0 (12.7-18.1)	17.5 (14.5-21.6)	20.2 (16.3-25.4)	23.0 (18.1-29.7)	26.9 (20.4-36.3)	30.1 (22.0-42.0)

¹ Precipitation frequency (PF) estimates in this table are based on frequency analysis of partial duration series (PDS). Numbers in parenthesis are PF estimates at lower and upper bounds of the 90% confidence interval. The probability that precipitation frequency estimates (for a given duration and average recurrence interval) will be greater than the upper bound (or less than the lower bound) is 5%. Estimates at upper bounds are not checked against probable maximum precipitation (PMP) estimates and may be higher than currently valid PMP values. Please refer to NOAA Atlas 14 document for more information.

[Back to Top](#)

PF graphical

PDS-based depth-duration-frequency (DDF) curves
 Latitude: 34.0055°, Longitude: -117.3380°

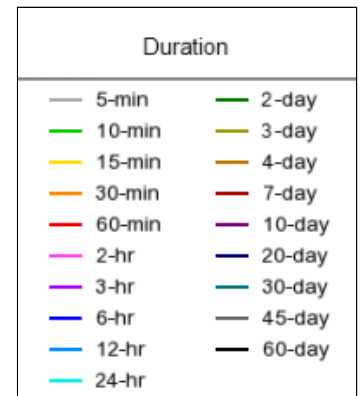
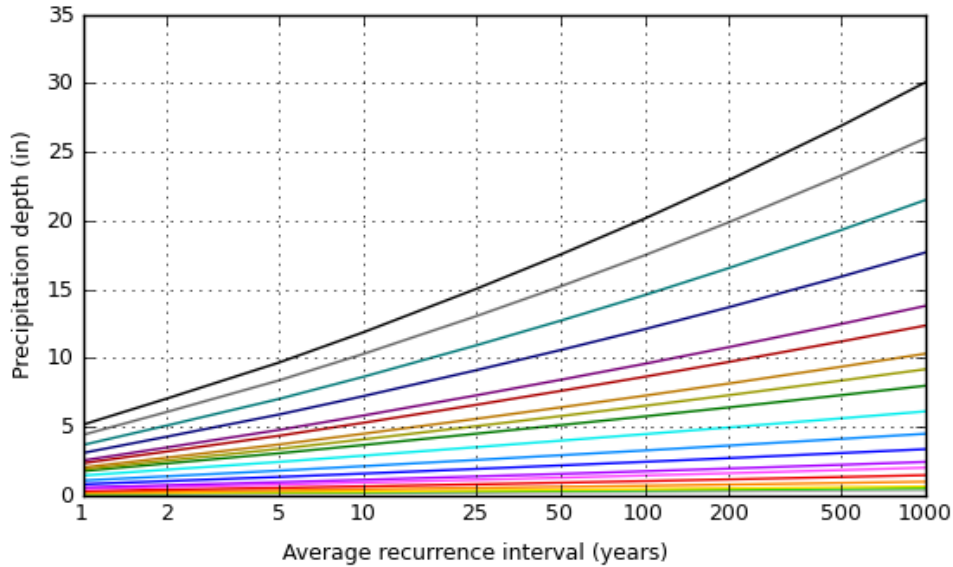
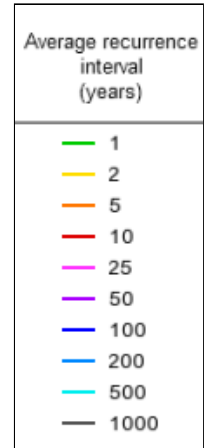
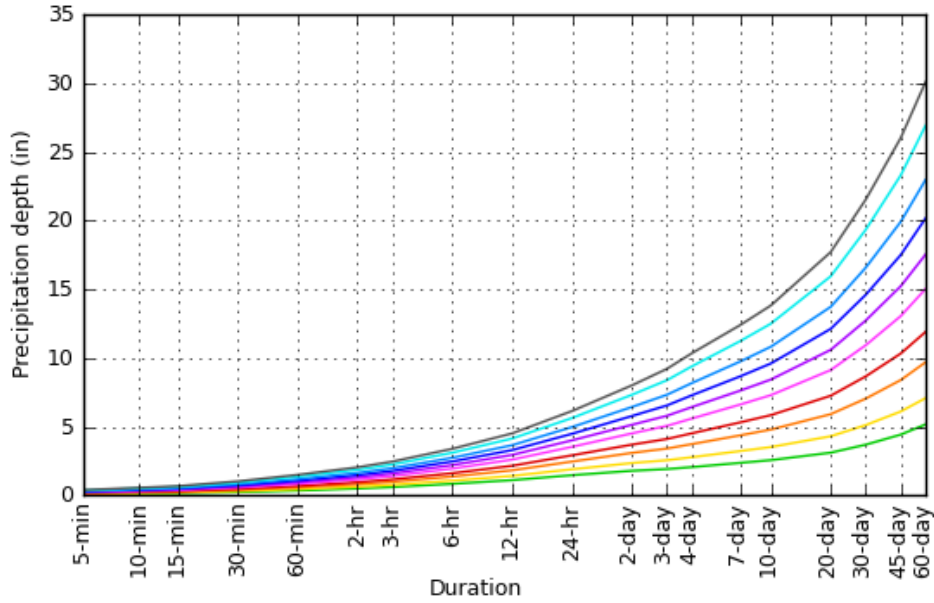

[Back to Top](#)

Maps & arials

Small scale terrain

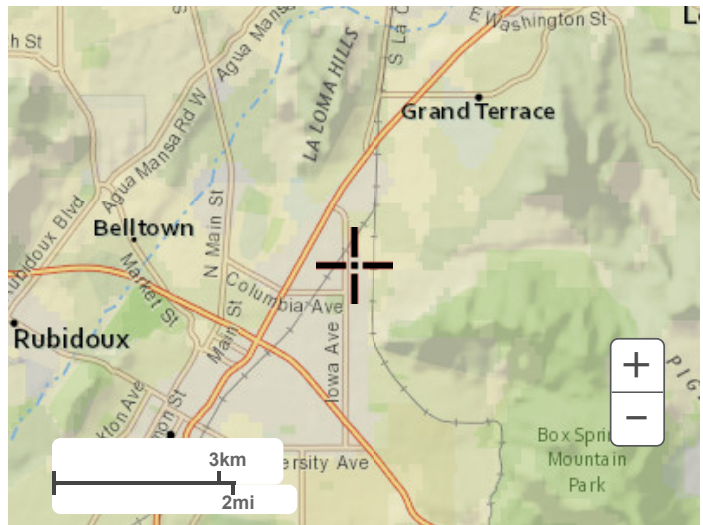

Large scale terrain



Large scale map



Large scale aerial



[Back to Top](#)

[US Department of Commerce](#)
[National Oceanic and Atmospheric Administration](#)
[National Weather Service](#)
[National Water Center](#)
1325 East West Highway
Silver Spring, MD 20910
Questions?: HDSC.Questions@noaa.gov

[Disclaimer](#)

PROJECT INFORMATION	
ENGINEERED PRODUCT MANAGER	
ADS SALES REP	
PROJECT NO.	



PALMYRITA AVENUE WAREHOUSES NO.1

RIVERSIDE, CA

MC-3500 STORMTECH CHAMBER SPECIFICATIONS

1. CHAMBERS SHALL BE STORMTECH MC-3500.
2. CHAMBERS SHALL BE ARCH-SHAPED AND SHALL BE MANUFACTURED FROM VIRGIN, IMPACT-MODIFIED POLYPROPYLENE COPOLYMERS.
3. CHAMBERS SHALL MEET THE REQUIREMENTS OF ASTM F2418, "STANDARD SPECIFICATION FOR POLYPROPYLENE (PP) CORRUGATED WALL STORMWATER COLLECTION CHAMBERS" CHAMBER CLASSIFICATION 45x76 DESIGNATION SS.
4. CHAMBER ROWS SHALL PROVIDE CONTINUOUS, UNOBSTRUCTED INTERNAL SPACE WITH NO INTERNAL SUPPORTS THAT WOULD IMPEDE FLOW OR LIMIT ACCESS FOR INSPECTION.
5. THE STRUCTURAL DESIGN OF THE CHAMBERS, THE STRUCTURAL BACKFILL, AND THE INSTALLATION REQUIREMENTS SHALL ENSURE THAT THE LOAD FACTORS SPECIFIED IN THE AASHTO LRFD BRIDGE DESIGN SPECIFICATIONS, SECTION 12.12, ARE MET FOR: 1) LONG-DURATION DEAD LOADS AND 2) SHORT-DURATION LIVE LOADS, BASED ON THE AASHTO DESIGN TRUCK WITH CONSIDERATION FOR IMPACT AND MULTIPLE VEHICLE PRESENCES.
6. CHAMBERS SHALL BE DESIGNED, TESTED AND ALLOWABLE LOAD CONFIGURATIONS DETERMINED IN ACCORDANCE WITH ASTM F2787, "STANDARD PRACTICE FOR STRUCTURAL DESIGN OF THERMOPLASTIC CORRUGATED WALL STORMWATER COLLECTION CHAMBERS". LOAD CONFIGURATIONS SHALL INCLUDE: 1) INSTANTANEOUS (<1 MIN) AASHTO DESIGN TRUCK LIVE LOAD ON MINIMUM COVER 2) MAXIMUM PERMANENT (75-YR) COVER LOAD AND 3) ALLOWABLE COVER WITH PARKED (1-WEEK) AASHTO DESIGN TRUCK.
7. REQUIREMENTS FOR HANDLING AND INSTALLATION:
 - TO MAINTAIN THE WIDTH OF CHAMBERS DURING SHIPPING AND HANDLING, CHAMBERS SHALL HAVE INTEGRAL, INTERLOCKING STACKING LUGS.
 - TO ENSURE A SECURE JOINT DURING INSTALLATION AND BACKFILL, THE HEIGHT OF THE CHAMBER JOINT SHALL NOT BE LESS THAN 3".
 - TO ENSURE THE INTEGRITY OF THE ARCH SHAPE DURING INSTALLATION, a) THE ARCH STIFFNESS CONSTANT SHALL BE GREATER THAN OR EQUAL TO 450 LBS/FT/%. THE ASC IS DEFINED IN SECTION 6.2.8 OF ASTM F2418. AND b) TO RESIST CHAMBER DEFORMATION DURING INSTALLATION AT ELEVATED TEMPERATURES (ABOVE 73° F / 23° C), CHAMBERS SHALL BE PRODUCED FROM REFLECTIVE GOLD OR YELLOW COLORS.
8. ONLY CHAMBERS THAT ARE APPROVED BY THE SITE DESIGN ENGINEER WILL BE ALLOWED. UPON REQUEST BY THE SITE DESIGN ENGINEER OR OWNER, THE CHAMBER MANUFACTURER SHALL SUBMIT A STRUCTURAL EVALUATION FOR APPROVAL BEFORE DELIVERING CHAMBERS TO THE PROJECT SITE AS FOLLOWS:
 - THE STRUCTURAL EVALUATION SHALL BE SEALED BY A REGISTERED PROFESSIONAL ENGINEER.
 - THE STRUCTURAL EVALUATION SHALL DEMONSTRATE THAT THE SAFETY FACTORS ARE GREATER THAN OR EQUAL TO 1.95 FOR DEAD LOAD AND 1.75 FOR LIVE LOAD, THE MINIMUM REQUIRED BY ASTM F2787 AND BY SECTIONS 3 AND 12.12 OF THE AASHTO LRFD BRIDGE DESIGN SPECIFICATIONS FOR THERMOPLASTIC PIPE.
 - THE TEST DERIVED CREEP MODULUS AS SPECIFIED IN ASTM F2418 SHALL BE USED FOR PERMANENT DEAD LOAD DESIGN EXCEPT THAT IT SHALL BE THE 75-YEAR MODULUS USED FOR DESIGN.
9. CHAMBERS AND END CAPS SHALL BE PRODUCED AT AN ISO 9001 CERTIFIED MANUFACTURING FACILITY.

IMPORTANT - NOTES FOR THE BIDDING AND INSTALLATION OF MC-3500 CHAMBER SYSTEM

1. STORMTECH MC-3500 CHAMBERS SHALL NOT BE INSTALLED UNTIL THE MANUFACTURER'S REPRESENTATIVE HAS COMPLETED A PRE-CONSTRUCTION MEETING WITH THE INSTALLERS.
2. STORMTECH MC-3500 CHAMBERS SHALL BE INSTALLED IN ACCORDANCE WITH THE "STORMTECH MC-3500/MC-4500 CONSTRUCTION GUIDE".
3. CHAMBERS ARE NOT TO BE BACKFILLED WITH A DOZER OR AN EXCAVATOR SITUATED OVER THE CHAMBERS. STORMTECH RECOMMENDS 3 BACKFILL METHODS:
 - STONESHOOTER LOCATED OFF THE CHAMBER BED.
 - BACKFILL AS ROWS ARE BUILT USING AN EXCAVATOR ON THE FOUNDATION STONE OR SUBGRADE.
 - BACKFILL FROM OUTSIDE THE EXCAVATION USING A LONG BOOM HOE OR EXCAVATOR.
4. THE FOUNDATION STONE SHALL BE LEVELED AND COMPACTED PRIOR TO PLACING CHAMBERS.
5. JOINTS BETWEEN CHAMBERS SHALL BE PROPERLY SEATED PRIOR TO PLACING STONE.
6. MAINTAIN MINIMUM - 6" (150 mm) SPACING BETWEEN THE CHAMBER ROWS.
7. INLET AND OUTLET MANIFOLDS MUST BE INSERTED A MINIMUM OF 12" (300 mm) INTO CHAMBER END CAPS.
8. EMBEDMENT STONE SURROUNDING CHAMBERS MUST BE A CLEAN, CRUSHED, ANGULAR STONE MEETING THE AASHTO M43 DESIGNATION OF #3 OR #4.
9. STONE MUST BE PLACED ON THE TOP CENTER OF THE CHAMBER TO ANCHOR THE CHAMBERS IN PLACE AND PRESERVE ROW SPACING.
10. THE CONTRACTOR MUST REPORT ANY DISCREPANCIES WITH CHAMBER FOUNDATION MATERIALS BEARING CAPACITIES TO THE SITE DESIGN ENGINEER.
11. ADS RECOMMENDS THE USE OF "FLEXSTORM CATCH IT" INSERTS DURING CONSTRUCTION FOR ALL INLETS TO PROTECT THE SUBSURFACE STORMWATER MANAGEMENT SYSTEM FROM CONSTRUCTION SITE RUNOFF.

NOTES FOR CONSTRUCTION EQUIPMENT



1. STORMTECH MC-3500 CHAMBERS SHALL BE INSTALLED IN ACCORDANCE WITH THE "STORMTECH MC-3500/MC-4500 CONSTRUCTION GUIDE".
2. THE USE OF EQUIPMENT OVER MC-3500 CHAMBERS IS LIMITED:
 - NO EQUIPMENT IS ALLOWED ON BARE CHAMBERS.
 - NO RUBBER TIRE LOADER, DUMP TRUCK, OR EXCAVATORS ARE ALLOWED UNTIL PROPER FILL DEPTHS ARE REACHED IN ACCORDANCE WITH THE "STORMTECH MC-3500/MC-4500 CONSTRUCTION GUIDE".
 - WEIGHT LIMITS FOR CONSTRUCTION EQUIPMENT CAN BE FOUND IN THE "STORMTECH MC-3500/MC-4500 CONSTRUCTION GUIDE".
3. FULL 36" (900 mm) OF STABILIZED COVER MATERIALS OVER THE CHAMBERS IS REQUIRED FOR DUMP TRUCK TRAVEL OR DUMPING.

USE OF A DOZER TO PUSH EMBEDMENT STONE BETWEEN THE ROWS OF CHAMBERS MAY CAUSE DAMAGE TO CHAMBERS AND IS NOT AN ACCEPTABLE BACKFILL METHOD. ANY CHAMBERS DAMAGED BY USING THE "DUMP AND PUSH" METHOD ARE NOT COVERED UNDER THE STORMTECH STANDARD WARRANTY.

CONTACT STORMTECH AT 1-888-892-2694 WITH ANY QUESTIONS ON INSTALLATION REQUIREMENTS OR WEIGHT LIMITS FOR CONSTRUCTION EQUIPMENT.

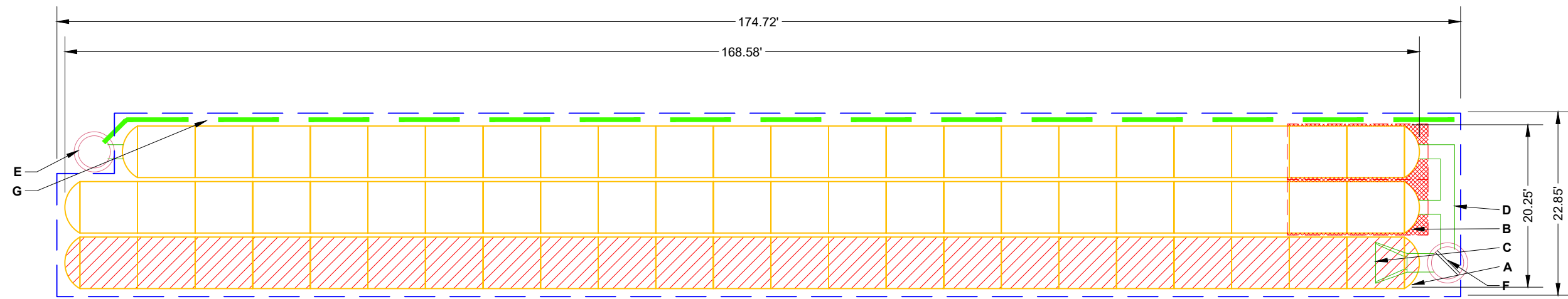
PROPOSED LAYOUT		CONCEPTUAL ELEVATIONS		*INVERT ABOVE BASE OF CHAMBER				
				PART TYPE	ITEM ON LAYOUT	DESCRIPTION	INVERT*	MAX FLOW
68	STORMTECH MC-3500 CHAMBERS	MAXIMUM ALLOWABLE GRADE (TOP OF PAVEMENT/UNPAVED):	12.50					
6	STORMTECH MC-3500 END CAPS	MINIMUM ALLOWABLE GRADE (UNPAVED WITH TRAFFIC):	6.50					
12	STONE ABOVE (in)	MINIMUM ALLOWABLE GRADE (UNPAVED NO TRAFFIC):	6.00	PREFABRICATED END CAP	A	24" BOTTOM CORED END CAP, PART#: MC3500IEPP24BC / TYP OF ALL 24" BOTTOM CONNECTIONS AND ISOLATOR PLUS ROWS	2.06"	
9	STONE BELOW (in)	MINIMUM ALLOWABLE GRADE (TOP OF RIGID CONCRETE PAVEMENT):	6.00					
40	STONE VOID	MINIMUM ALLOWABLE GRADE (BASE OF FLEXIBLE PAVEMENT):	6.00	PREFABRICATED END CAP	B	18" BOTTOM CORED END CAP, PART#: MC3500IEPP18BC / TYP OF ALL 18" BOTTOM CONNECTIONS	1.77"	
13204	INSTALLED SYSTEM VOLUME (CF) (PERIMETER STONE INCLUDED) (COVER STONE INCLUDED) (BASE STONE INCLUDED)	TOP OF STONE:	5.50	FLAMP	C	INSTALL FLAMP ON 24" ACCESS PIPE / PART#: MC350024RAMP		
		TOP OF MC-3500 CHAMBER:	4.50	MANIFOLD	D	18" x 18" BOTTOM MANIFOLD, ADS N-12	1.77"	
		24" ISOLATOR ROW PLUS INVERT:	0.92	CONCRETE STRUCTURE	E	OCS (DESIGN BY ENGINEER / PROVIDED BY OTHERS)		4.0 CFS OUT
		18" x 18" BOTTOM MANIFOLD INVERT:	0.90	CONCRETE STRUCTURE	F	(DESIGN BY ENGINEER / PROVIDED BY OTHERS)		11.0 CFS IN
3938	SYSTEM AREA (SF)	18" BOTTOM CONNECTION INVERT:	0.90					
395.1	SYSTEM PERIMETER (ft)	BOTTOM OF MC-3500 CHAMBER:	0.75	W/WEIR				
		UNDERDRAIN INVERT:	0.00	UNDERDRAIN	G	6" ADS N-12 DUAL WALL PERFORATED HDPE UNDERDRAIN		
		BOTTOM OF STONE:	0.00					

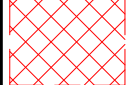

-  ISOLATOR ROW PLUS (SEE DETAIL)
-  PLACE MINIMUM 17.50' OF ADSPLUS175 WOVEN GEOTEXTILE OVER BEDDING STONE AND UNDERNEATH CHAMBER FEET FOR SCOUR PROTECTION AT ALL CHAMBER INLET ROWS
-  BED LIMITS

NOTES

- MANIFOLD SIZE TO BE DETERMINED BY SITE DESIGN ENGINEER. SEE TECH NOTE #6.32 FOR MANIFOLD SIZING GUIDANCE.
- DUE TO THE ADAPTATION OF THIS CHAMBER SYSTEM TO SPECIFIC SITE AND DESIGN CONSTRAINTS, IT MAY BE NECESSARY TO CUT AND COUPLE ADDITIONAL PIPE TO STANDARD MANIFOLD COMPONENTS IN THE FIELD.
- THE SITE DESIGN ENGINEER MUST REVIEW ELEVATIONS AND IF NECESSARY ADJUST GRADING TO ENSURE THE CHAMBER COVER REQUIREMENTS ARE MET.
- THIS CHAMBER SYSTEM WAS DESIGNED WITHOUT SITE-SPECIFIC INFORMATION ON SOIL CONDITIONS OR BEARING CAPACITY. THE SITE DESIGN ENGINEER IS RESPONSIBLE FOR DETERMINING THE SUITABILITY OF THE SOIL AND PROVIDING THE BEARING CAPACITY OF THE INSITU SOILS. THE BASE STONE DEPTH MAY BE INCREASED OR DECREASED ONCE THIS INFORMATION IS PROVIDED.
- **NOT FOR CONSTRUCTION:** THIS LAYOUT IS FOR DIMENSIONAL PURPOSES ONLY TO PROVE CONCEPT & THE REQUIRED STORAGE VOLUME CAN BE ACHIEVED ON SITE.

StormTech®
Chamber System

888-892-2694 | WWW.STORMTECH.COM

4640 TRUEMAN BLVD
HILLIARD, OH 43026
1-800-733-7473

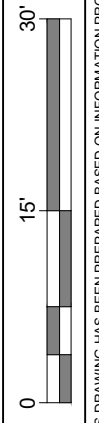

PALMYRITA AVENUE
WAREHOUSES NO. 1
RIVERSIDE, CA

DATE: _____ DRAWN: AS

PROJECT #: _____ CHECKED: N/A

SHEET
2 OF 5

THIS DRAWING HAS BEEN PREPARED BASED ON INFORMATION PROVIDED TO ADS UNDER THE DIRECTION OF THE SITE DESIGN ENGINEER OR OTHER PROJECT REPRESENTATIVE. THE SITE DESIGN ENGINEER SHALL REVIEW THIS DRAWING PRIOR TO CONSTRUCTION. IT IS THE ULTIMATE RESPONSIBILITY OF THE SITE DESIGN ENGINEER TO ENSURE THAT THE PRODUCT(S) DEPICTED AND ALL ASSOCIATED DETAILS MEET ALL APPLICABLE LAWS, REGULATIONS, AND PROJECT REQUIREMENTS.

ACCEPTABLE FILL MATERIALS: STORMTECH MC-3500 CHAMBER SYSTEMS

MATERIAL LOCATION		DESCRIPTION	AASHTO MATERIAL CLASSIFICATIONS	COMPACTION / DENSITY REQUIREMENT
D	FINAL FILL: FILL MATERIAL FOR LAYER 'D' STARTS FROM THE TOP OF THE 'C' LAYER TO THE BOTTOM OF FLEXIBLE PAVEMENT OR UNPAVED FINISHED GRADE ABOVE. NOTE THAT PAVEMENT SUBBASE MAY BE PART OF THE 'D' LAYER	ANY SOIL/ROCK MATERIALS, NATIVE SOILS, OR PER ENGINEER'S PLANS. CHECK PLANS FOR PAVEMENT SUBGRADE REQUIREMENTS.	N/A	PREPARE PER SITE DESIGN ENGINEER'S PLANS. PAVED INSTALLATIONS MAY HAVE STRINGENT MATERIAL AND PREPARATION REQUIREMENTS.
C	INITIAL FILL: FILL MATERIAL FOR LAYER 'C' STARTS FROM THE TOP OF THE EMBEDMENT STONE ('B' LAYER) TO 24" (600 mm) ABOVE THE TOP OF THE CHAMBER. NOTE THAT PAVEMENT SUBBASE MAY BE A PART OF THE 'C' LAYER.	GRANULAR WELL-GRADED SOIL/AGGREGATE MIXTURES, <35% FINES OR PROCESSED AGGREGATE. MOST PAVEMENT SUBBASE MATERIALS CAN BE USED IN LIEU OF THIS LAYER.	AASHTO M145 ¹ A-1, A-2-4, A-3 OR AASHTO M43 ¹ 3, 357, 4, 467, 5, 56, 57, 6, 67, 68, 7, 78, 8, 89, 9, 10	BEGIN COMPACTIONS AFTER 24" (600 mm) OF MATERIAL OVER THE CHAMBERS IS REACHED. COMPACT ADDITIONAL LAYERS IN 12" (300 mm) MAX LIFTS TO A MIN. 95% PROCTOR DENSITY FOR WELL GRADED MATERIAL AND 95% RELATIVE DENSITY FOR PROCESSED AGGREGATE MATERIALS.
B	EMBEDMENT STONE: FILL SURROUNDING THE CHAMBERS FROM THE FOUNDATION STONE ('A' LAYER) TO THE 'C' LAYER ABOVE.	CLEAN, CRUSHED, ANGULAR STONE	AASHTO M43 ¹ 3, 4	NO COMPACTION REQUIRED.
A	FOUNDATION STONE: FILL BELOW CHAMBERS FROM THE SUBGRADE UP TO THE FOOT (BOTTOM) OF THE CHAMBER.	CLEAN, CRUSHED, ANGULAR STONE	AASHTO M43 ¹ 3, 4	PLATE COMPACT OR ROLL TO ACHIEVE A FLAT SURFACE. ^{2,3}

PLEASE NOTE:

- THE LISTED AASHTO DESIGNATIONS ARE FOR GRADATIONS ONLY. THE STONE MUST ALSO BE CLEAN, CRUSHED, ANGULAR. FOR EXAMPLE, A SPECIFICATION FOR #4 STONE WOULD STATE: "CLEAN, CRUSHED, ANGULAR NO. 4 (AASHTO M43) STONE".
- STORMTECH COMPACTION REQUIREMENTS ARE MET FOR 'A' LOCATION MATERIALS WHEN PLACED AND COMPACTED IN 9" (230 mm) (MAX) LIFTS USING TWO FULL COVERAGES WITH A VIBRATORY COMPACTOR.
- WHERE INFILTRATION SURFACES MAY BE COMPROMISED BY COMPACTION, FOR STANDARD DESIGN LOAD CONDITIONS, A FLAT SURFACE MAY BE ACHIEVED BY RAKING OR DRAGGING WITHOUT COMPACTION EQUIPMENT. FOR SPECIAL LOAD DESIGNS, CONTACT STORMTECH FOR COMPACTION REQUIREMENTS.
- ONCE LAYER 'C' IS PLACED, ANY SOIL/MATERIAL CAN BE PLACED IN LAYER 'D' UP TO THE FINISHED GRADE. MOST PAVEMENT SUBBASE SOILS CAN BE USED TO REPLACE THE MATERIAL REQUIREMENTS OF LAYER 'C' OR 'D' AT THE SITE DESIGN ENGINEER'S DISCRETION.

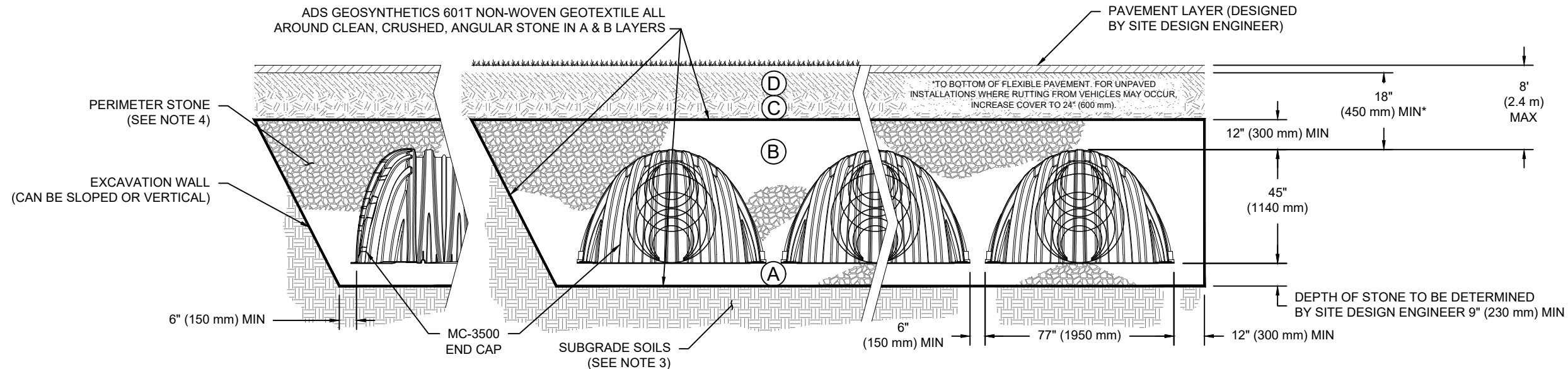

NOTES:

- CHAMBERS SHALL MEET THE REQUIREMENTS OF ASTM F2418, "STANDARD SPECIFICATION FOR POLYPROPYLENE (PP) CORRUGATED WALL STORMWATER COLLECTION CHAMBERS" CHAMBER CLASSIFICATION 45x76 DESIGNATION SS.
- MC-3500 CHAMBERS SHALL BE DESIGNED IN ACCORDANCE WITH ASTM F2787 "STANDARD PRACTICE FOR STRUCTURAL DESIGN OF THERMOPLASTIC CORRUGATED WALL STORMWATER COLLECTION CHAMBERS".
- THE SITE DESIGN ENGINEER IS RESPONSIBLE FOR ASSESSING THE BEARING RESISTANCE (ALLOWABLE BEARING CAPACITY) OF THE SUBGRADE SOILS AND THE DEPTH OF FOUNDATION STONE WITH CONSIDERATION FOR THE RANGE OF EXPECTED SOIL MOISTURE CONDITIONS.
- PERIMETER STONE MUST BE EXTENDED HORIZONTALLY TO THE EXCAVATION WALL FOR BOTH VERTICAL AND SLOPED EXCAVATION WALLS.
- REQUIREMENTS FOR HANDLING AND INSTALLATION:
 - TO MAINTAIN THE WIDTH OF CHAMBERS DURING SHIPPING AND HANDLING, CHAMBERS SHALL HAVE INTEGRAL, INTERLOCKING STACKING LUGS.
 - TO ENSURE A SECURE JOINT DURING INSTALLATION AND BACKFILL, THE HEIGHT OF THE CHAMBER JOINT SHALL NOT BE LESS THAN 3".
 - TO ENSURE THE INTEGRITY OF THE ARCH SHAPE DURING INSTALLATION, a) THE ARCH STIFFNESS CONSTANT SHALL BE GREATER THAN OR EQUAL TO 450 LBS/FT²%. THE ASC IS DEFINED IN SECTION 6.2.8 OF ASTM F2418. AND b) TO RESIST CHAMBER DEFORMATION DURING INSTALLATION AT ELEVATED TEMPERATURES (ABOVE 73° F / 23° C), CHAMBERS SHALL BE PRODUCED FROM REFLECTIVE GOLD OR YELLOW COLORS.

PALMYRITA AVENUE
WAREHOUSES NO. 1
RIVERSIDE, CA

DRAWN: AS
DATE:
PROJECT #:
CHECKED: N/A

DATE	DRW	CHK	DESCRIPTION

StormTech®
Chamber System

888-892-2694 | WWW.STORMTECH.COM

4640 TRUEMAN BLVD
HILLIARD, OH 43026
1-800-733-7473



THIS DRAWING HAS BEEN PREPARED BASED ON INFORMATION PROVIDED TO ADS UNDER THE DIRECTION OF THE SITE DESIGN ENGINEER OR OTHER PROJECT REPRESENTATIVE. THE SITE DESIGN ENGINEER SHALL REVIEW THIS DRAWING PRIOR TO CONSTRUCTION. IT IS THE ULTIMATE RESPONSIBILITY OF THE SITE DESIGN ENGINEER TO ENSURE THAT THE PRODUCT(S) DEPICTED AND ALL ASSOCIATED DETAILS MEET ALL APPLICABLE LAWS, REGULATIONS, AND PROJECT REQUIREMENTS.

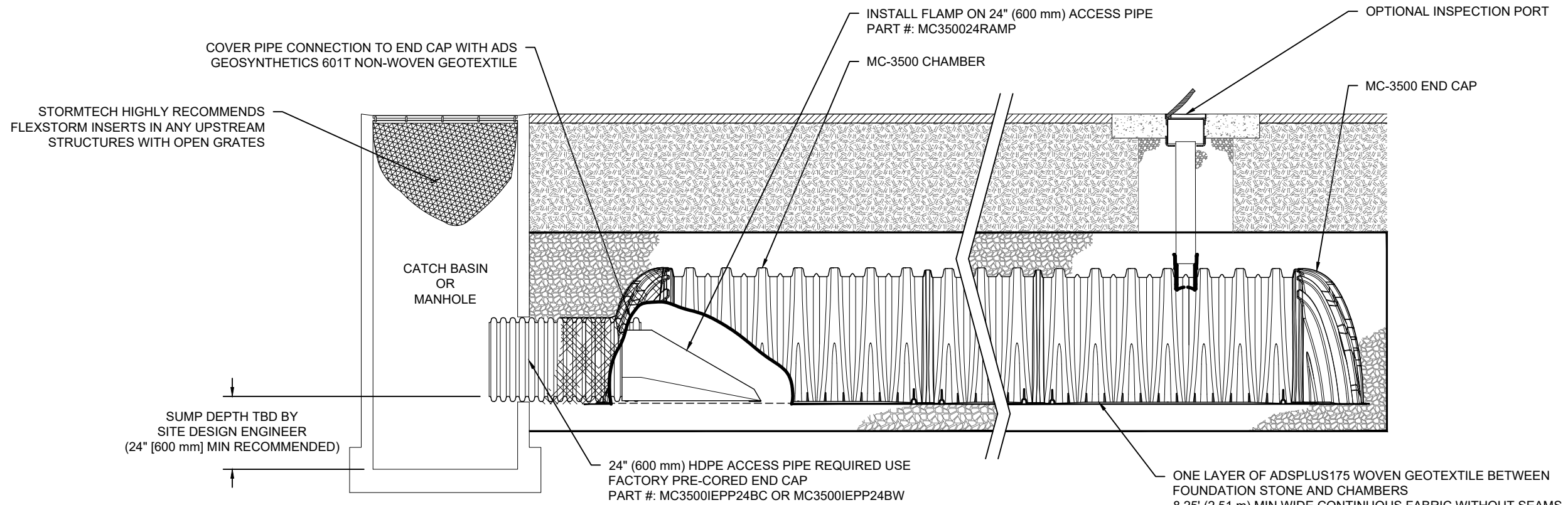

MC-3500 ISOLATOR ROW PLUS DETAIL

NTS

INSPECTION & MAINTENANCE

- STEP 1) INSPECT ISOLATOR ROW PLUS FOR SEDIMENT
- A. INSPECTION PORTS (IF PRESENT)
 - A.1. REMOVE/OPEN LID ON NYLOPLAST INLINE DRAIN
 - A.2. REMOVE AND CLEAN FLEXSTORM FILTER IF INSTALLED
 - A.3. USING A FLASHLIGHT AND STADIA ROD, MEASURE DEPTH OF SEDIMENT AND RECORD ON MAINTENANCE LOG
 - A.4. LOWER A CAMERA INTO ISOLATOR ROW PLUS FOR VISUAL INSPECTION OF SEDIMENT LEVELS (OPTIONAL)
 - A.5. IF SEDIMENT IS AT, OR ABOVE, 3" (80 mm) PROCEED TO STEP 2. IF NOT, PROCEED TO STEP 3.
 - B. ALL ISOLATOR PLUS ROWS
 - B.1. REMOVE COVER FROM STRUCTURE AT UPSTREAM END OF ISOLATOR ROW PLUS
 - B.2. USING A FLASHLIGHT, INSPECT DOWN THE ISOLATOR ROW PLUS THROUGH OUTLET PIPE
 - i) MIRRORS ON POLES OR CAMERAS MAY BE USED TO AVOID A CONFINED SPACE ENTRY
 - ii) FOLLOW OSHA REGULATIONS FOR CONFINED SPACE ENTRY IF ENTERING MANHOLE
 - B.3. IF SEDIMENT IS AT, OR ABOVE, 3" (80 mm) PROCEED TO STEP 2. IF NOT, PROCEED TO STEP 3.
- STEP 2) CLEAN OUT ISOLATOR ROW PLUS USING THE JETVAC PROCESS
- A. A FIXED CULVERT CLEANING NOZZLE WITH REAR FACING SPREAD OF 45" (1.1 m) OR MORE IS PREFERRED
 - B. APPLY MULTIPLE PASSES OF JETVAC UNTIL BACKFLUSH WATER IS CLEAN
 - C. VACUUM STRUCTURE SUMP AS REQUIRED
- STEP 3) REPLACE ALL COVERS, GRATES, FILTERS, AND LIDS; RECORD OBSERVATIONS AND ACTIONS.
- STEP 4) INSPECT AND CLEAN BASINS AND MANHOLES UPSTREAM OF THE STORMTECH SYSTEM.

NOTES

1. INSPECT EVERY 6 MONTHS DURING THE FIRST YEAR OF OPERATION. ADJUST THE INSPECTION INTERVAL BASED ON PREVIOUS OBSERVATIONS OF SEDIMENT ACCUMULATION AND HIGH WATER ELEVATIONS.
2. CONDUCT JETTING AND VACTORING ANNUALLY OR WHEN INSPECTION SHOWS THAT MAINTENANCE IS NECESSARY.

PALMYRITA AVENUE
WAREHOUSES NO. 1
RIVERSIDE, CA

DATE: DRAWN: AS
PROJECT #: CHECKED: N/A

DATE	DRW	CHK	DESCRIPTION

StormTech®
Chamber System

888-892-2694 | WWW.STORMTECH.COM

4640 TRUEMAN BLVD
HILLIARD, OH 43026
1-800-733-7473



THIS DRAWING HAS BEEN PREPARED BASED ON INFORMATION PROVIDED TO ADS UNDER THE DIRECTION OF THE SITE DESIGN ENGINEER OR OTHER PROJECT REPRESENTATIVE. THE SITE DESIGN ENGINEER SHALL REVIEW THIS DRAWING PRIOR TO CONSTRUCTION. IT IS THE ULTIMATE RESPONSIBILITY OF THE SITE DESIGN ENGINEER TO ENSURE THAT THE PRODUCT(S) DEPICTED AND ALL ASSOCIATED DETAILS MEET ALL APPLICABLE LAWS, REGULATIONS, AND PROJECT REQUIREMENTS.

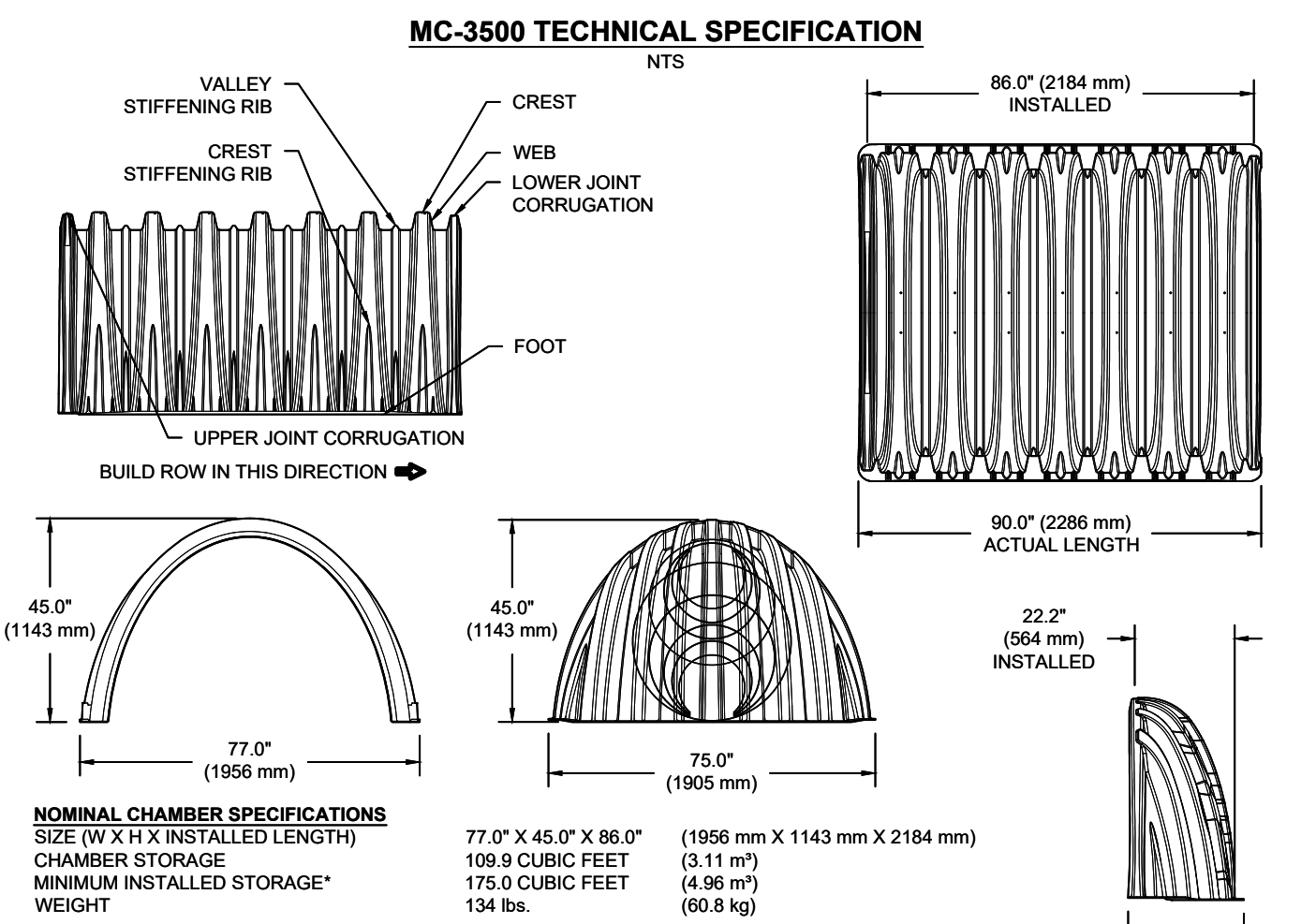
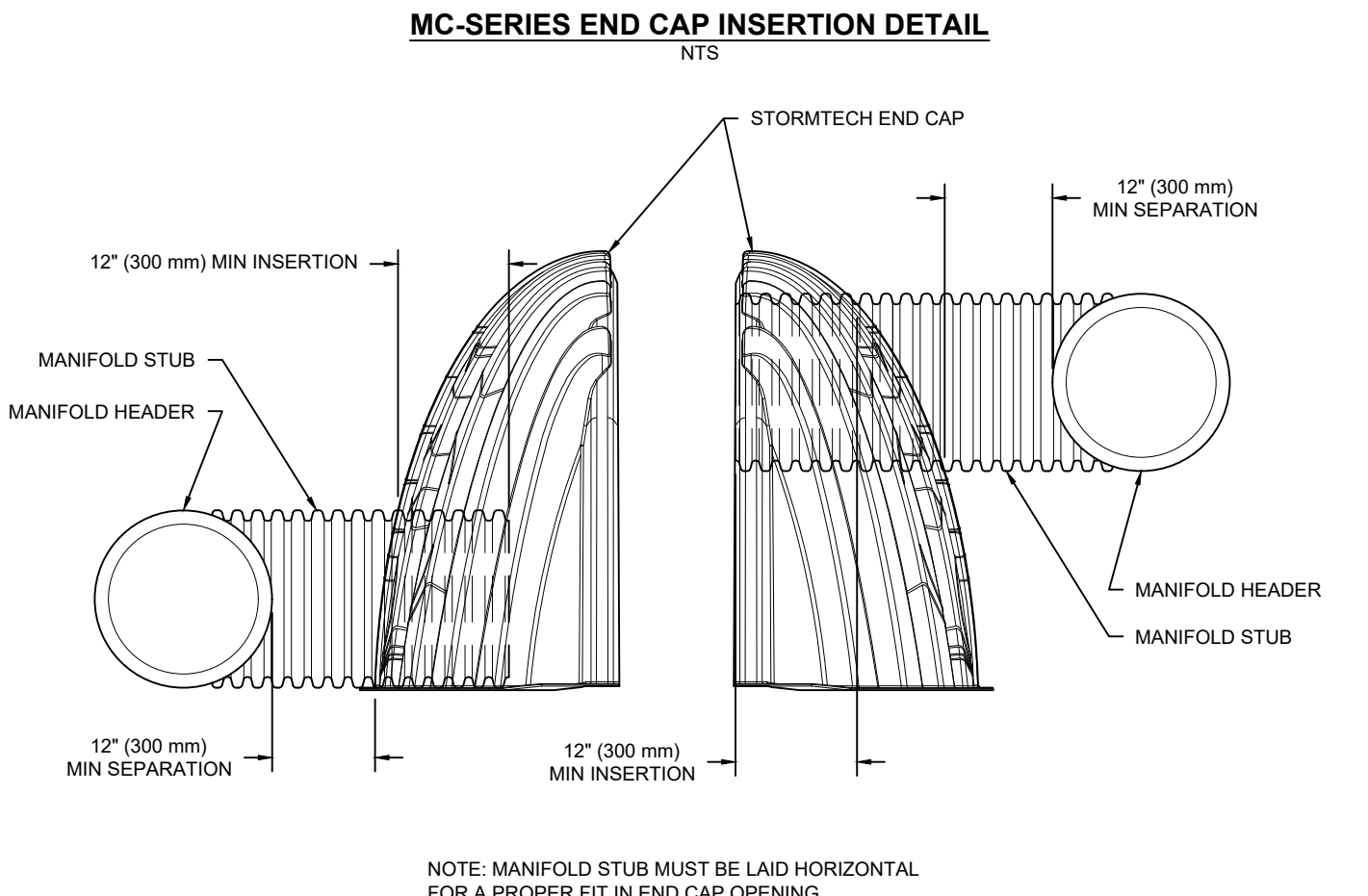
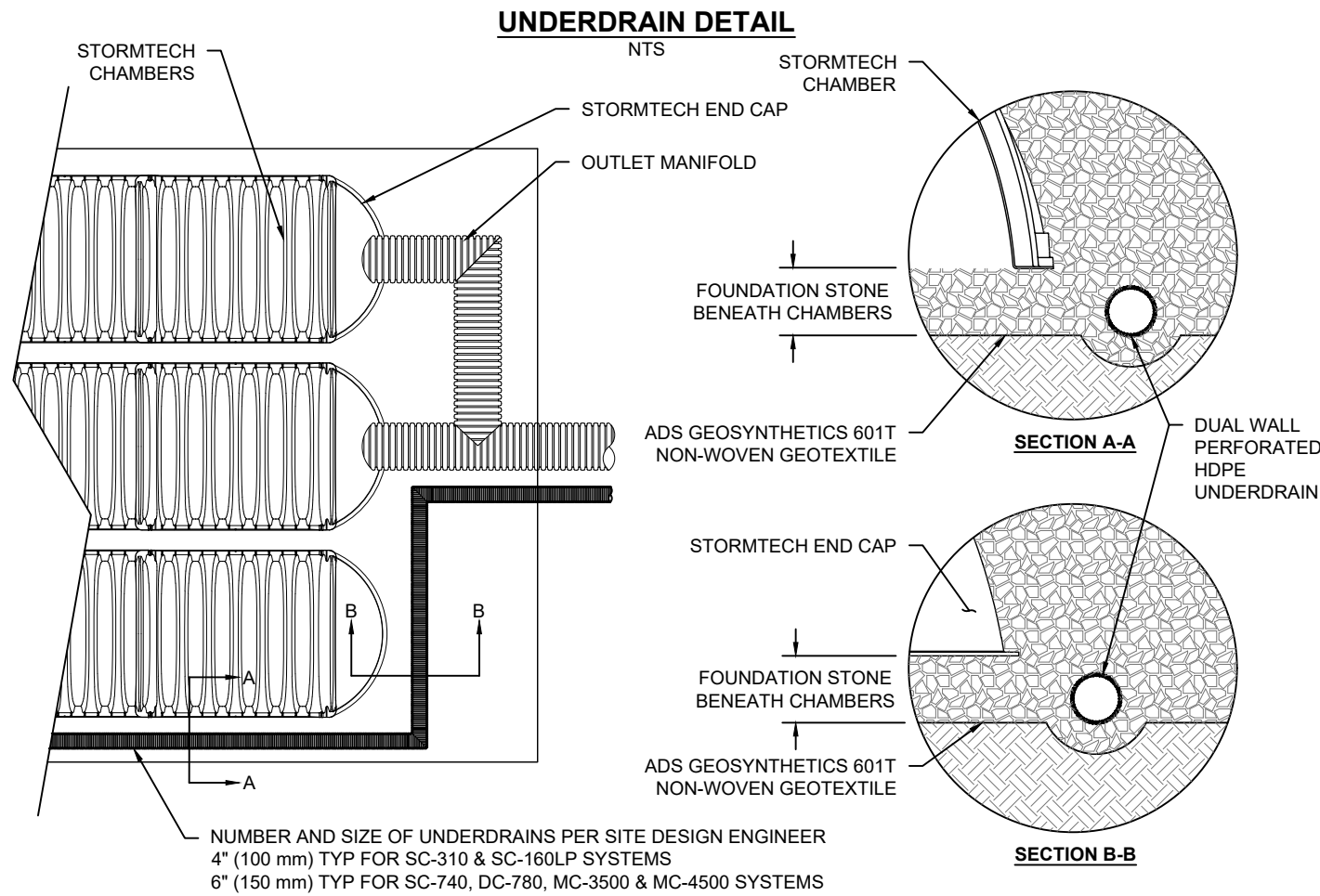

STUBS AT BOTTOM OF END CAP FOR PART NUMBERS ENDING WITH "B"
 STUBS AT TOP OF END CAP FOR PART NUMBERS ENDING WITH "T"
 END CAPS WITH A WELDED CROWN PLATE END WITH "C"
 END CAPS WITH A PREFABRICATED WELDED STUB END WITH "W"

PART #	STUB	B	C
MC3500IEPP06T		33.21" (844 mm)	---
MC3500IEPP06B	6" (150 mm)	---	0.66" (17 mm)
MC3500IEPP08T		31.16" (791 mm)	---
MC3500IEPP08B	8" (200 mm)	---	0.81" (21 mm)
MC3500IEPP10T		29.04" (738 mm)	---
MC3500IEPP10B	10" (250 mm)	---	0.93" (24 mm)
MC3500IEPP12T		26.36" (670 mm)	---
MC3500IEPP12B	12" (300 mm)	---	1.35" (34 mm)
MC3500IEPP15T		23.39" (594 mm)	---
MC3500IEPP15B	15" (375 mm)	---	1.50" (38 mm)
MC3500IEPP18TC		20.03" (509 mm)	---
MC3500IEPP18TW			
MC3500IEPP18BC	18" (450 mm)	---	1.77" (45 mm)
MC3500IEPP18BW			
MC3500IEPP24TC		14.48" (368 mm)	---
MC3500IEPP24TW			
MC3500IEPP24BC	24" (600 mm)	---	2.06" (52 mm)
MC3500IEPP24BW			
MC3500IEPP30BC	30" (750 mm)	---	2.75" (70 mm)

CUSTOM PRECORED INVERTS ARE AVAILABLE UPON REQUEST. INVENTORIED MANIFOLDS INCLUDE 12-24" (300-600 mm) SIZE ON SIZE AND 15-48" (375-1200 mm) ECCENTRIC MANIFOLDS. CUSTOM INVERT LOCATIONS ON THE MC-3500 END CAP CUT IN THE FIELD ARE NOT RECOMMENDED FOR PIPE SIZES GREATER THAN 10" (250 mm). THE INVERT LOCATION IN COLUMN 'B' ARE THE HIGHEST POSSIBLE FOR THE PIPE SIZE.

PALMYRITA AVENUE
WAREHOUSES NO. 1
RIVERSIDE, CA

DATE: _____ PROJECT #: _____

DRAWN: AS CHECKED: N/A

DESCRIPTION

DATE

DRW

CHK

DATE

DRW

CHK

DATE

DRW

CHK

DATE

DRW

CHK

StormTech®
Chamber System

888-892-2694 | WWW.STORMTECH.COM

4640 TRUEMAN BLVD
HILLIARD, OH 43026
1-800-733-7473

ADS

THIS DRAWING HAS BEEN PREPARED BASED ON INFORMATION PROVIDED TO ADS UNDER THE DIRECTION OF THE SITE DESIGN ENGINEER OR OTHER PROJECT REPRESENTATIVE. THE SITE DESIGN ENGINEER SHALL REVIEW THIS DRAWING PRIOR TO CONSTRUCTION. IT IS THE ULTIMATE RESPONSIBILITY OF THE SITE DESIGN ENGINEER TO ENSURE THAT THE PRODUCT(S) DEPICTED AND ALL ASSOCIATED DETAILS MEET ALL APPLICABLE LAWS, REGULATIONS, AND PROJECT REQUIREMENTS.

SHEET
5 OF 5

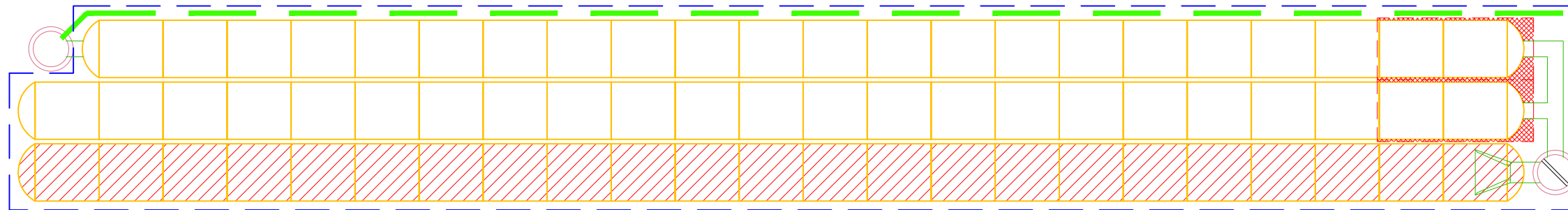

PROJECT INFORMATION	
ENGINEERED PRODUCT MANAGER	
ADS SALES REP	
PROJECT NO.	



PALMYRITA AVENUE WAREHOUSES NO. 2

RIVERSIDE, CA

MC-3500 STORMTECH CHAMBER SPECIFICATIONS

1. CHAMBERS SHALL BE STORMTECH MC-3500.
2. CHAMBERS SHALL BE ARCH-SHAPED AND SHALL BE MANUFACTURED FROM VIRGIN, IMPACT-MODIFIED POLYPROPYLENE COPOLYMERS.
3. CHAMBERS SHALL MEET THE REQUIREMENTS OF ASTM F2418, "STANDARD SPECIFICATION FOR POLYPROPYLENE (PP) CORRUGATED WALL STORMWATER COLLECTION CHAMBERS" CHAMBER CLASSIFICATION 45x76 DESIGNATION SS.
4. CHAMBER ROWS SHALL PROVIDE CONTINUOUS, UNOBSTRUCTED INTERNAL SPACE WITH NO INTERNAL SUPPORTS THAT WOULD IMPEDE FLOW OR LIMIT ACCESS FOR INSPECTION.
5. THE STRUCTURAL DESIGN OF THE CHAMBERS, THE STRUCTURAL BACKFILL, AND THE INSTALLATION REQUIREMENTS SHALL ENSURE THAT THE LOAD FACTORS SPECIFIED IN THE AASHTO LRFD BRIDGE DESIGN SPECIFICATIONS, SECTION 12.12, ARE MET FOR: 1) LONG-DURATION DEAD LOADS AND 2) SHORT-DURATION LIVE LOADS, BASED ON THE AASHTO DESIGN TRUCK WITH CONSIDERATION FOR IMPACT AND MULTIPLE VEHICLE PRESENCES.
6. CHAMBERS SHALL BE DESIGNED, TESTED AND ALLOWABLE LOAD CONFIGURATIONS DETERMINED IN ACCORDANCE WITH ASTM F2787, "STANDARD PRACTICE FOR STRUCTURAL DESIGN OF THERMOPLASTIC CORRUGATED WALL STORMWATER COLLECTION CHAMBERS". LOAD CONFIGURATIONS SHALL INCLUDE: 1) INSTANTANEOUS (<1 MIN) AASHTO DESIGN TRUCK LIVE LOAD ON MINIMUM COVER 2) MAXIMUM PERMANENT (75-YR) COVER LOAD AND 3) ALLOWABLE COVER WITH PARKED (1-WEEK) AASHTO DESIGN TRUCK.
7. REQUIREMENTS FOR HANDLING AND INSTALLATION:
 - TO MAINTAIN THE WIDTH OF CHAMBERS DURING SHIPPING AND HANDLING, CHAMBERS SHALL HAVE INTEGRAL, INTERLOCKING STACKING LUGS.
 - TO ENSURE A SECURE JOINT DURING INSTALLATION AND BACKFILL, THE HEIGHT OF THE CHAMBER JOINT SHALL NOT BE LESS THAN 3".
 - TO ENSURE THE INTEGRITY OF THE ARCH SHAPE DURING INSTALLATION, a) THE ARCH STIFFNESS CONSTANT SHALL BE GREATER THAN OR EQUAL TO 450 LBS/FT/%. THE ASC IS DEFINED IN SECTION 6.2.8 OF ASTM F2418. AND b) TO RESIST CHAMBER DEFORMATION DURING INSTALLATION AT ELEVATED TEMPERATURES (ABOVE 73° F / 23° C), CHAMBERS SHALL BE PRODUCED FROM REFLECTIVE GOLD OR YELLOW COLORS.
8. ONLY CHAMBERS THAT ARE APPROVED BY THE SITE DESIGN ENGINEER WILL BE ALLOWED. UPON REQUEST BY THE SITE DESIGN ENGINEER OR OWNER, THE CHAMBER MANUFACTURER SHALL SUBMIT A STRUCTURAL EVALUATION FOR APPROVAL BEFORE DELIVERING CHAMBERS TO THE PROJECT SITE AS FOLLOWS:
 - THE STRUCTURAL EVALUATION SHALL BE SEALED BY A REGISTERED PROFESSIONAL ENGINEER.
 - THE STRUCTURAL EVALUATION SHALL DEMONSTRATE THAT THE SAFETY FACTORS ARE GREATER THAN OR EQUAL TO 1.95 FOR DEAD LOAD AND 1.75 FOR LIVE LOAD, THE MINIMUM REQUIRED BY ASTM F2787 AND BY SECTIONS 3 AND 12.12 OF THE AASHTO LRFD BRIDGE DESIGN SPECIFICATIONS FOR THERMOPLASTIC PIPE.
 - THE TEST DERIVED CREEP MODULUS AS SPECIFIED IN ASTM F2418 SHALL BE USED FOR PERMANENT DEAD LOAD DESIGN EXCEPT THAT IT SHALL BE THE 75-YEAR MODULUS USED FOR DESIGN.
9. CHAMBERS AND END CAPS SHALL BE PRODUCED AT AN ISO 9001 CERTIFIED MANUFACTURING FACILITY.

IMPORTANT - NOTES FOR THE BIDDING AND INSTALLATION OF MC-3500 CHAMBER SYSTEM

1. STORMTECH MC-3500 CHAMBERS SHALL NOT BE INSTALLED UNTIL THE MANUFACTURER'S REPRESENTATIVE HAS COMPLETED A PRE-CONSTRUCTION MEETING WITH THE INSTALLERS.
2. STORMTECH MC-3500 CHAMBERS SHALL BE INSTALLED IN ACCORDANCE WITH THE "STORMTECH MC-3500/MC-4500 CONSTRUCTION GUIDE".
3. CHAMBERS ARE NOT TO BE BACKFILLED WITH A DOZER OR AN EXCAVATOR SITUATED OVER THE CHAMBERS. STORMTECH RECOMMENDS 3 BACKFILL METHODS:
 - STONESHOOTER LOCATED OFF THE CHAMBER BED.
 - BACKFILL AS ROWS ARE BUILT USING AN EXCAVATOR ON THE FOUNDATION STONE OR SUBGRADE.
 - BACKFILL FROM OUTSIDE THE EXCAVATION USING A LONG BOOM HOE OR EXCAVATOR.
4. THE FOUNDATION STONE SHALL BE LEVELED AND COMPACTED PRIOR TO PLACING CHAMBERS.
5. JOINTS BETWEEN CHAMBERS SHALL BE PROPERLY SEATED PRIOR TO PLACING STONE.
6. MAINTAIN MINIMUM - 6" (150 mm) SPACING BETWEEN THE CHAMBER ROWS.
7. INLET AND OUTLET MANIFOLDS MUST BE INSERTED A MINIMUM OF 12" (300 mm) INTO CHAMBER END CAPS.
8. EMBEDMENT STONE SURROUNDING CHAMBERS MUST BE A CLEAN, CRUSHED, ANGULAR STONE MEETING THE AASHTO M43 DESIGNATION OF #3 OR #4.
9. STONE MUST BE PLACED ON THE TOP CENTER OF THE CHAMBER TO ANCHOR THE CHAMBERS IN PLACE AND PRESERVE ROW SPACING.
10. THE CONTRACTOR MUST REPORT ANY DISCREPANCIES WITH CHAMBER FOUNDATION MATERIALS BEARING CAPACITIES TO THE SITE DESIGN ENGINEER.
11. ADS RECOMMENDS THE USE OF "FLEXSTORM CATCH IT" INSERTS DURING CONSTRUCTION FOR ALL INLETS TO PROTECT THE SUBSURFACE STORMWATER MANAGEMENT SYSTEM FROM CONSTRUCTION SITE RUNOFF.

NOTES FOR CONSTRUCTION EQUIPMENT

1. STORMTECH MC-3500 CHAMBERS SHALL BE INSTALLED IN ACCORDANCE WITH THE "STORMTECH MC-3500/MC-4500 CONSTRUCTION GUIDE".
2. THE USE OF EQUIPMENT OVER MC-3500 CHAMBERS IS LIMITED:
 - NO EQUIPMENT IS ALLOWED ON BARE CHAMBERS.
 - NO RUBBER TIRE LOADER, DUMP TRUCK, OR EXCAVATORS ARE ALLOWED UNTIL PROPER FILL DEPTHS ARE REACHED IN ACCORDANCE WITH THE "STORMTECH MC-3500/MC-4500 CONSTRUCTION GUIDE".
 - WEIGHT LIMITS FOR CONSTRUCTION EQUIPMENT CAN BE FOUND IN THE "STORMTECH MC-3500/MC-4500 CONSTRUCTION GUIDE".
3. FULL 36" (900 mm) OF STABILIZED COVER MATERIALS OVER THE CHAMBERS IS REQUIRED FOR DUMP TRUCK TRAVEL OR DUMPING.

USE OF A DOZER TO PUSH EMBEDMENT STONE BETWEEN THE ROWS OF CHAMBERS MAY CAUSE DAMAGE TO CHAMBERS AND IS NOT AN ACCEPTABLE BACKFILL METHOD. ANY CHAMBERS DAMAGED BY USING THE "DUMP AND PUSH" METHOD ARE NOT COVERED UNDER THE STORMTECH STANDARD WARRANTY.

CONTACT STORMTECH AT 1-888-892-2694 WITH ANY QUESTIONS ON INSTALLATION REQUIREMENTS OR WEIGHT LIMITS FOR CONSTRUCTION EQUIPMENT.

PROPOSED LAYOUT		CONCEPTUAL ELEVATIONS		*INVERT ABOVE BASE OF CHAMBER				
				PART TYPE	ITEM ON LAYOUT	DESCRIPTION	INVERT*	MAX FLOW
67	STORMTECH MC-3500 CHAMBERS	MAXIMUM ALLOWABLE GRADE (TOP OF PAVEMENT/UNPAVED):	12.50					
6	STORMTECH MC-3500 END CAPS	MINIMUM ALLOWABLE GRADE (UNPAVED WITH TRAFFIC):	6.50					
12	STONE ABOVE (in)	MINIMUM ALLOWABLE GRADE (UNPAVED NO TRAFFIC):	6.00	PREFABRICATED END CAP	A	24" BOTTOM CORED END CAP, PART#: MC3500IEPP24BC / TYP OF ALL 24" BOTTOM CONNECTIONS AND ISOLATOR PLUS ROWS	2.06"	
9	STONE BELOW (in)	MINIMUM ALLOWABLE GRADE (TOP OF RIGID CONCRETE PAVEMENT):	6.00					
40	STONE VOID	MINIMUM ALLOWABLE GRADE (BASE OF FLEXIBLE PAVEMENT):	6.00	PREFABRICATED END CAP	B	18" BOTTOM CORED END CAP, PART#: MC3500IEPP18BC / TYP OF ALL 18" BOTTOM CONNECTIONS	1.77"	
13160	INSTALLED SYSTEM VOLUME (CF) (PERIMETER STONE INCLUDED) (COVER STONE INCLUDED) (BASE STONE INCLUDED)	TOP OF STONE:	5.50	FLAMP	C	INSTALL FLAMP ON 24" ACCESS PIPE / PART#: MC350024RAMP		
		TOP OF MC-3500 CHAMBER:	4.50	MANIFOLD	D	18" x 18" BOTTOM MANIFOLD, ADS N-12	1.77"	
		24" ISOLATOR ROW PLUS INVERT:	0.92	MANIFOLD	E	18" x 18" BOTTOM MANIFOLD, ADS N-12	1.77"	
		18" x 18" BOTTOM MANIFOLD INVERT:	0.90	CONCRETE STRUCTURE	F	OCS (DESIGN BY ENGINEER / PROVIDED BY OTHERS)		8.0 CFS OUT
3948	SYSTEM AREA (SF)	18" x 18" BOTTOM MANIFOLD INVERT:	0.90	CONCRETE STRUCTURE	G	(DESIGN BY ENGINEER / PROVIDED BY OTHERS)		11.0 CFS IN
395.1	SYSTEM PERIMETER (ft)	18" BOTTOM CONNECTION INVERT:	0.90	UNDERDRAIN	H	6" ADS N-12 DUAL WALL PERFORATED HDPE UNDERDRAIN		
		BOTTOM OF MC-3500 CHAMBER:	0.75					
		UNDERDRAIN INVERT:	0.00					
		BOTTOM OF STONE:	0.00					

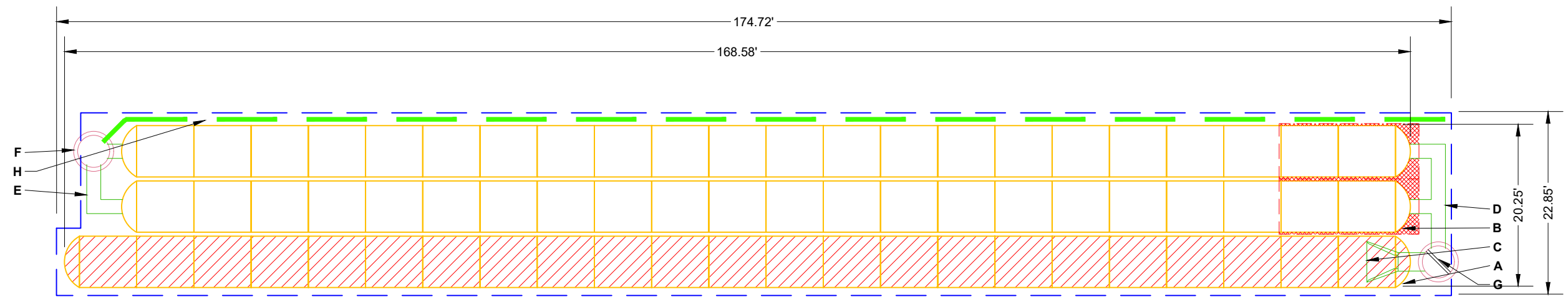

- ISOLATOR ROW PLUS (SEE DETAIL)
- PLACE MINIMUM 17.50' OF ADSPLUS175 WOVEN GEOTEXTILE OVER BEDDING STONE AND UNDERNEATH CHAMBER FEET FOR SCOUR PROTECTION AT ALL CHAMBER INLET ROWS
- BED LIMITS

NOTES

- MANIFOLD SIZE TO BE DETERMINED BY SITE DESIGN ENGINEER. SEE TECH NOTE #6.32 FOR MANIFOLD SIZING GUIDANCE.
- DUE TO THE ADAPTATION OF THIS CHAMBER SYSTEM TO SPECIFIC SITE AND DESIGN CONSTRAINTS, IT MAY BE NECESSARY TO CUT AND COUPLE ADDITIONAL PIPE TO STANDARD MANIFOLD COMPONENTS IN THE FIELD.
- THE SITE DESIGN ENGINEER MUST REVIEW ELEVATIONS AND IF NECESSARY ADJUST GRADING TO ENSURE THE CHAMBER COVER REQUIREMENTS ARE MET.
- THIS CHAMBER SYSTEM WAS DESIGNED WITHOUT SITE-SPECIFIC INFORMATION ON SOIL CONDITIONS OR BEARING CAPACITY. THE SITE DESIGN ENGINEER IS RESPONSIBLE FOR DETERMINING THE SUITABILITY OF THE SOIL AND PROVIDING THE BEARING CAPACITY OF THE INSITU SOILS. THE BASE STONE DEPTH MAY BE INCREASED OR DECREASED ONCE THIS INFORMATION IS PROVIDED.
- **NOT FOR CONSTRUCTION:** THIS LAYOUT IS FOR DIMENSIONAL PURPOSES ONLY TO PROVE CONCEPT & THE REQUIRED STORAGE VOLUME CAN BE ACHIEVED ON SITE.

PALMYRITA AVENUE
WAREHOUSES NO. 2
RIVERSIDE, CA

DATE: _____

PROJECT #: _____

DRAWN: AS

CHECKED: N/A

DATE	DRW	CHK	DESCRIPTION

StormTech®
Chamber System

888-892-2694 | WWW.STORMTECH.COM

4640 TRUEMAN BLVD
HILLIARD, OH 43026
1-800-733-7473

SHEET
2 OF 5

THIS DRAWING HAS BEEN PREPARED BASED ON INFORMATION PROVIDED TO ADS UNDER THE DIRECTION OF THE SITE DESIGN ENGINEER OR OTHER PROJECT REPRESENTATIVE. THE SITE DESIGN ENGINEER SHALL REVIEW THIS DRAWING PRIOR TO CONSTRUCTION. IT IS THE ULTIMATE RESPONSIBILITY OF THE SITE DESIGN ENGINEER TO ENSURE THAT THE PRODUCT(S) DEPICTED AND ALL ASSOCIATED DETAILS MEET ALL APPLICABLE LAWS, REGULATIONS, AND PROJECT REQUIREMENTS.

ACCEPTABLE FILL MATERIALS: STORMTECH MC-3500 CHAMBER SYSTEMS

MATERIAL LOCATION	DESCRIPTION	AASHTO MATERIAL CLASSIFICATIONS	COMPACTION / DENSITY REQUIREMENT
D	FINAL FILL: FILL MATERIAL FOR LAYER 'D' STARTS FROM THE TOP OF THE 'C' LAYER TO THE BOTTOM OF FLEXIBLE PAVEMENT OR UNPAVED FINISHED GRADE ABOVE. NOTE THAT PAVEMENT SUBBASE MAY BE PART OF THE 'D' LAYER	N/A	PREPARE PER SITE DESIGN ENGINEER'S PLANS. PAVED INSTALLATIONS MAY HAVE STRINGENT MATERIAL AND PREPARATION REQUIREMENTS.
C	INITIAL FILL: FILL MATERIAL FOR LAYER 'C' STARTS FROM THE TOP OF THE EMBEDMENT STONE ('B' LAYER) TO 24" (600 mm) ABOVE THE TOP OF THE CHAMBER. NOTE THAT PAVEMENT SUBBASE MAY BE A PART OF THE 'C' LAYER.	AASHTO M145 ¹ A-1, A-2-4, A-3 OR AASHTO M43 ¹ 3, 357, 4, 467, 5, 56, 57, 6, 67, 68, 7, 78, 8, 89, 9, 10	BEGIN COMPACTIONS AFTER 24" (600 mm) OF MATERIAL OVER THE CHAMBERS IS REACHED. COMPACT ADDITIONAL LAYERS IN 12" (300 mm) MAX LIFTS TO A MIN. 95% PROCTOR DENSITY FOR WELL GRADED MATERIAL AND 95% RELATIVE DENSITY FOR PROCESSED AGGREGATE MATERIALS.
B	EMBEDMENT STONE: FILL SURROUNDING THE CHAMBERS FROM THE FOUNDATION STONE ('A' LAYER) TO THE 'C' LAYER ABOVE.	AASHTO M43 ¹ 3, 4	NO COMPACTION REQUIRED.
A	FOUNDATION STONE: FILL BELOW CHAMBERS FROM THE SUBGRADE UP TO THE FOOT (BOTTOM) OF THE CHAMBER.	AASHTO M43 ¹ 3, 4	PLATE COMPACT OR ROLL TO ACHIEVE A FLAT SURFACE. ^{2,3}

PLEASE NOTE:

1. THE LISTED AASHTO DESIGNATIONS ARE FOR GRADATIONS ONLY. THE STONE MUST ALSO BE CLEAN, CRUSHED, ANGULAR. FOR EXAMPLE, A SPECIFICATION FOR #4 STONE WOULD STATE: "CLEAN, CRUSHED, ANGULAR NO. 4 (AASHTO M43) STONE".
2. STORMTECH COMPACTION REQUIREMENTS ARE MET FOR 'A' LOCATION MATERIALS WHEN PLACED AND COMPACTED IN 9" (230 mm) (MAX) LIFTS USING TWO FULL COVERAGES WITH A VIBRATORY COMPACTOR.
3. WHERE INFILTRATION SURFACES MAY BE COMPROMISED BY COMPACTION, FOR STANDARD DESIGN LOAD CONDITIONS, A FLAT SURFACE MAY BE ACHIEVED BY RAKING OR DRAGGING WITHOUT COMPACTION EQUIPMENT. FOR SPECIAL LOAD DESIGNS, CONTACT STORMTECH FOR COMPACTION REQUIREMENTS.
4. ONCE LAYER 'C' IS PLACED, ANY SOIL/MATERIAL CAN BE PLACED IN LAYER 'D' UP TO THE FINISHED GRADE. MOST PAVEMENT SUBBASE SOILS CAN BE USED TO REPLACE THE MATERIAL REQUIREMENTS OF LAYER 'C' OR 'D' AT THE SITE DESIGN ENGINEER'S DISCRETION.

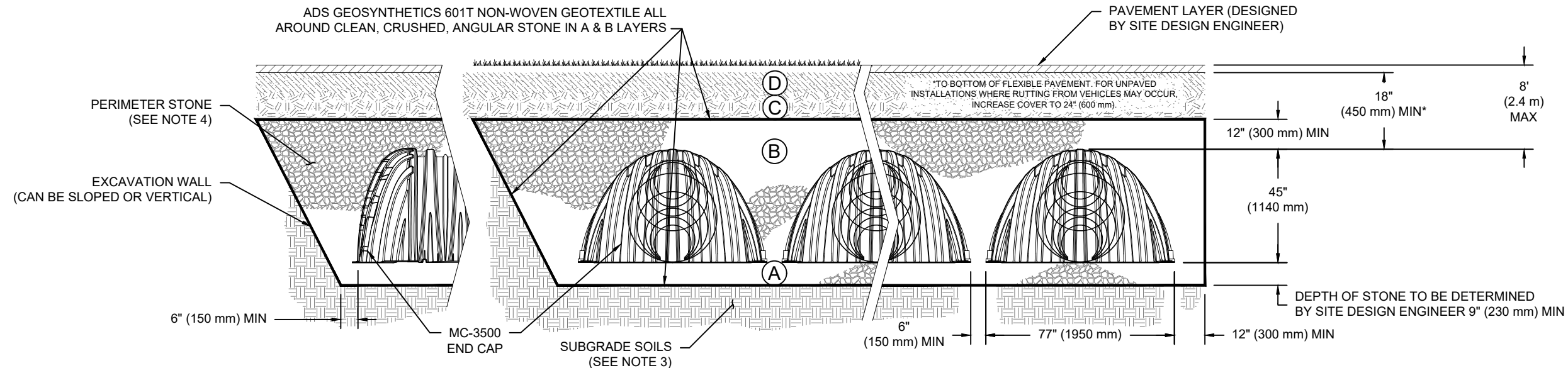

NOTES:

1. CHAMBERS SHALL MEET THE REQUIREMENTS OF ASTM F2418, "STANDARD SPECIFICATION FOR POLYPROPYLENE (PP) CORRUGATED WALL STORMWATER COLLECTION CHAMBERS" CHAMBER CLASSIFICATION 45x76 DESIGNATION SS.
2. MC-3500 CHAMBERS SHALL BE DESIGNED IN ACCORDANCE WITH ASTM F2787 "STANDARD PRACTICE FOR STRUCTURAL DESIGN OF THERMOPLASTIC CORRUGATED WALL STORMWATER COLLECTION CHAMBERS".
3. THE SITE DESIGN ENGINEER IS RESPONSIBLE FOR ASSESSING THE BEARING RESISTANCE (ALLOWABLE BEARING CAPACITY) OF THE SUBGRADE SOILS AND THE DEPTH OF FOUNDATION STONE WITH CONSIDERATION FOR THE RANGE OF EXPECTED SOIL MOISTURE CONDITIONS.
4. PERIMETER STONE MUST BE EXTENDED HORIZONTALLY TO THE EXCAVATION WALL FOR BOTH VERTICAL AND SLOPED EXCAVATION WALLS.
5. REQUIREMENTS FOR HANDLING AND INSTALLATION:
 - TO MAINTAIN THE WIDTH OF CHAMBERS DURING SHIPPING AND HANDLING, CHAMBERS SHALL HAVE INTEGRAL, INTERLOCKING STACKING LUGS.
 - TO ENSURE A SECURE JOINT DURING INSTALLATION AND BACKFILL, THE HEIGHT OF THE CHAMBER JOINT SHALL NOT BE LESS THAN 3".
 - TO ENSURE THE INTEGRITY OF THE ARCH SHAPE DURING INSTALLATION, a) THE ARCH STIFFNESS CONSTANT SHALL BE GREATER THAN OR EQUAL TO 450 LBS/FT²%. THE ASC IS DEFINED IN SECTION 6.2.8 OF ASTM F2418. AND b) TO RESIST CHAMBER DEFORMATION DURING INSTALLATION AT ELEVATED TEMPERATURES (ABOVE 73° F / 23° C), CHAMBERS SHALL BE PRODUCED FROM REFLECTIVE GOLD OR YELLOW COLORS.

PALMYRITA AVENUE
WAREHOUSES NO. 2
RIVERSIDE, CA

DRAWN: AS
CHECKED: N/A
DATE:
PROJECT #:

DESCRIPTION
CHK
DRW
DATE

StormTech®
Chamber System

888-892-2694 | WWW.STORMTECH.COM

4640 TRUEMAN BLVD
HILLIARD, OH 43026
1-800-733-7473



THIS DRAWING HAS BEEN PREPARED BASED ON INFORMATION PROVIDED TO ADS UNDER THE DIRECTION OF THE SITE DESIGN ENGINEER OR OTHER PROJECT REPRESENTATIVE. THE SITE DESIGN ENGINEER SHALL REVIEW THIS DRAWING PRIOR TO CONSTRUCTION. IT IS THE ULTIMATE RESPONSIBILITY OF THE SITE DESIGN ENGINEER TO ENSURE THAT THE PRODUCT(S) DEPICTED AND ALL ASSOCIATED DETAILS MEET ALL APPLICABLE LAWS, REGULATIONS, AND PROJECT REQUIREMENTS.

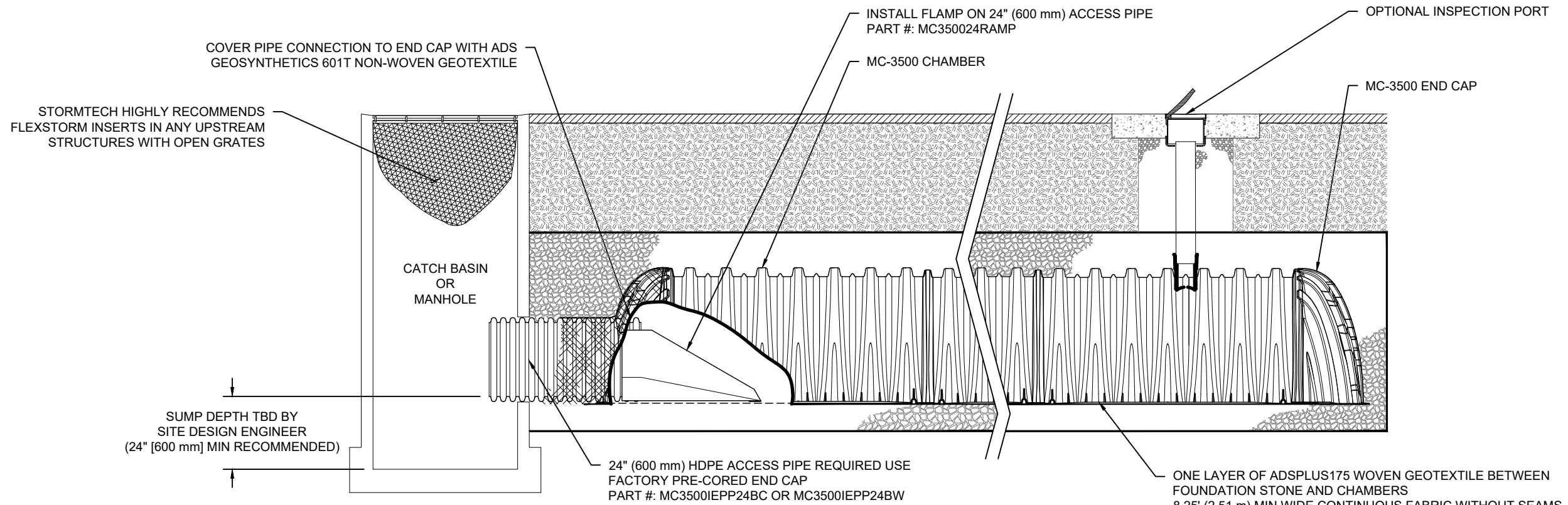

MC-3500 ISOLATOR ROW PLUS DETAIL

NTS

INSPECTION & MAINTENANCE

- STEP 1) INSPECT ISOLATOR ROW PLUS FOR SEDIMENT
- A. INSPECTION PORTS (IF PRESENT)
 - A.1. REMOVE/OPEN LID ON NYLOPLAST INLINE DRAIN
 - A.2. REMOVE AND CLEAN FLEXSTORM FILTER IF INSTALLED
 - A.3. USING A FLASHLIGHT AND STADIA ROD, MEASURE DEPTH OF SEDIMENT AND RECORD ON MAINTENANCE LOG
 - A.4. LOWER A CAMERA INTO ISOLATOR ROW PLUS FOR VISUAL INSPECTION OF SEDIMENT LEVELS (OPTIONAL)
 - A.5. IF SEDIMENT IS AT, OR ABOVE, 3" (80 mm) PROCEED TO STEP 2. IF NOT, PROCEED TO STEP 3.
 - B. ALL ISOLATOR PLUS ROWS
 - B.1. REMOVE COVER FROM STRUCTURE AT UPSTREAM END OF ISOLATOR ROW PLUS
 - B.2. USING A FLASHLIGHT, INSPECT DOWN THE ISOLATOR ROW PLUS THROUGH OUTLET PIPE
 - i) MIRRORS ON POLES OR CAMERAS MAY BE USED TO AVOID A CONFINED SPACE ENTRY
 - ii) FOLLOW OSHA REGULATIONS FOR CONFINED SPACE ENTRY IF ENTERING MANHOLE
 - B.3. IF SEDIMENT IS AT, OR ABOVE, 3" (80 mm) PROCEED TO STEP 2. IF NOT, PROCEED TO STEP 3.
- STEP 2) CLEAN OUT ISOLATOR ROW PLUS USING THE JETVAC PROCESS
- A. A FIXED CULVERT CLEANING NOZZLE WITH REAR FACING SPREAD OF 45" (1.1 m) OR MORE IS PREFERRED
 - B. APPLY MULTIPLE PASSES OF JETVAC UNTIL BACKFLUSH WATER IS CLEAN
 - C. VACUUM STRUCTURE SUMP AS REQUIRED
- STEP 3) REPLACE ALL COVERS, GRATES, FILTERS, AND LIDS; RECORD OBSERVATIONS AND ACTIONS.
- STEP 4) INSPECT AND CLEAN BASINS AND MANHOLES UPSTREAM OF THE STORMTECH SYSTEM.

NOTES

1. INSPECT EVERY 6 MONTHS DURING THE FIRST YEAR OF OPERATION. ADJUST THE INSPECTION INTERVAL BASED ON PREVIOUS OBSERVATIONS OF SEDIMENT ACCUMULATION AND HIGH WATER ELEVATIONS.
2. CONDUCT JETTING AND VACTORING ANNUALLY OR WHEN INSPECTION SHOWS THAT MAINTENANCE IS NECESSARY.

PALMYRITA AVENUE
WAREHOUSES NO. 2
RIVERSIDE, CA

DATE: _____ DRAWN: AS
PROJECT #: _____ CHECKED: N/A

DATE	DRW	CHK	DESCRIPTION

StormTech®
Chamber System

888-892-2694 | WWW.STORMTECH.COM

4640 TRUEMAN BLVD
HILLIARD, OH 43026
1-800-733-7473



THIS DRAWING HAS BEEN PREPARED BASED ON INFORMATION PROVIDED TO ADS UNDER THE DIRECTION OF THE SITE DESIGN ENGINEER OR OTHER PROJECT REPRESENTATIVE. THE SITE DESIGN ENGINEER SHALL REVIEW THIS DRAWING PRIOR TO CONSTRUCTION. IT IS THE ULTIMATE RESPONSIBILITY OF THE SITE DESIGN ENGINEER TO ENSURE THAT THE PRODUCT(S) DEPICTED AND ALL ASSOCIATED DETAILS MEET ALL APPLICABLE LAWS, REGULATIONS, AND PROJECT REQUIREMENTS.

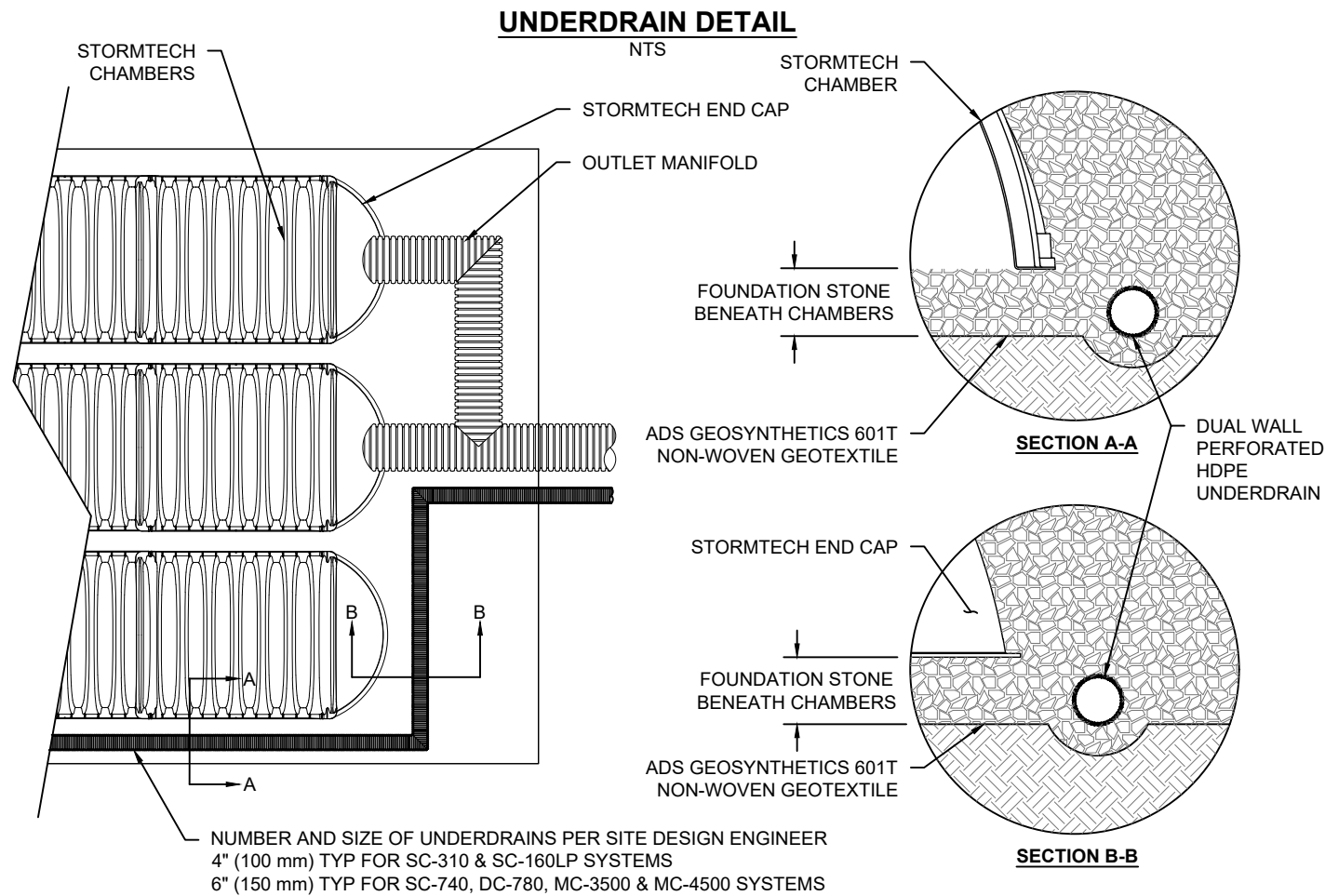

MC-3500 TECHNICAL SPECIFICATION

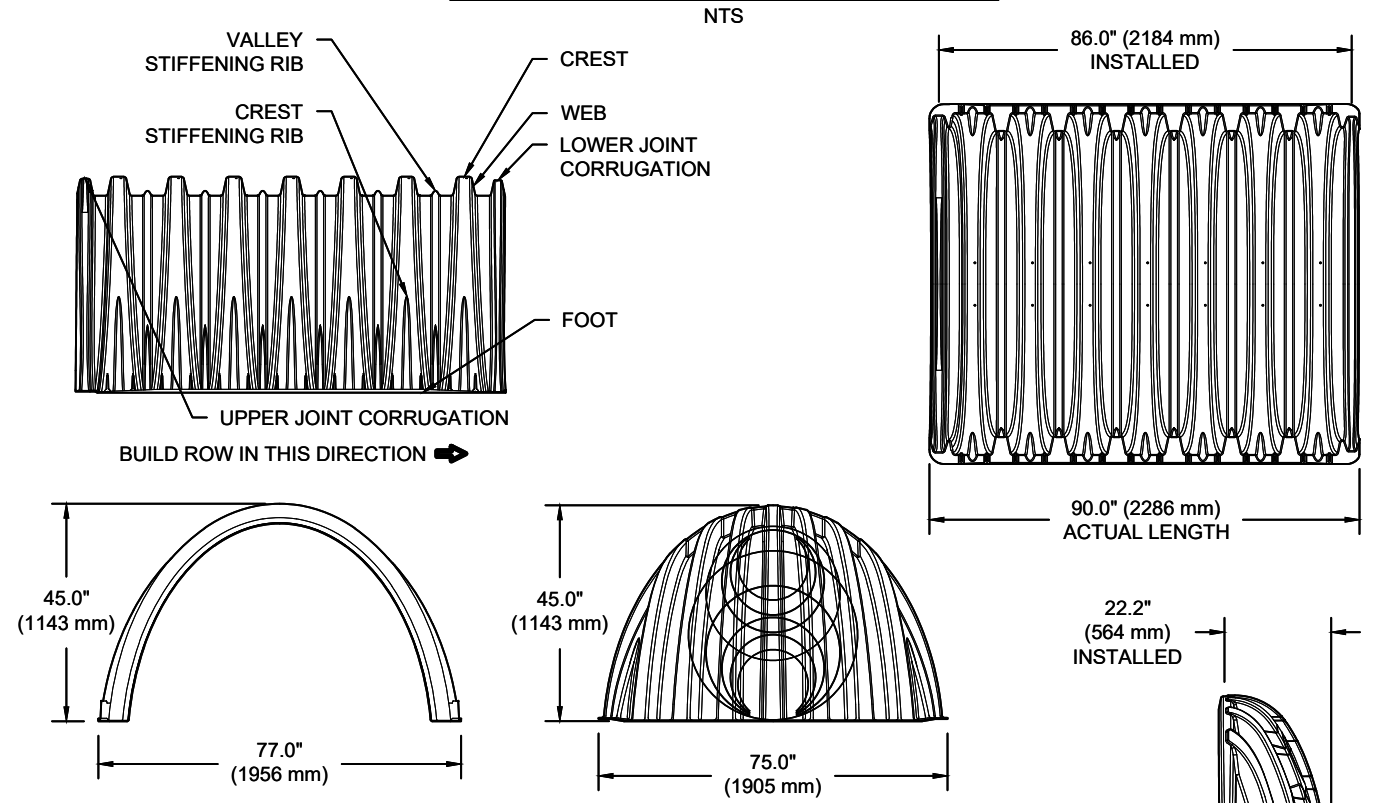

NOMINAL CHAMBER SPECIFICATIONS

SIZE (W X H X INSTALLED LENGTH)		
77.0" X 45.0" X 86.0"	(1956 mm X 1143 mm X 2184 mm)	
CHAMBER STORAGE	109.9 CUBIC FEET	(3.11 m ³)
MINIMUM INSTALLED STORAGE*	175.0 CUBIC FEET	(4.96 m ³)
WEIGHT	134 lbs.	(60.8 kg)

NOMINAL END CAP SPECIFICATIONS

SIZE (W X H X INSTALLED LENGTH)		
75.0" X 45.0" X 22.2"	(1905 mm X 1143 mm X 564 mm)	
END CAP STORAGE	14.9 CUBIC FEET	(0.42 m ³)
MINIMUM INSTALLED STORAGE*	45.1 CUBIC FEET	(1.28 m ³)
WEIGHT	49 lbs.	(22.2 kg)

*ASSUMES 12" (305 mm) STONE ABOVE, 9" (229 mm) STONE FOUNDATION, 6" SPACING BETWEEN CHAMBERS, 6" (152 mm) STONE PERIMETER IN FRONT OF END CAPS AND 40% STONE POROSITY

STUBS AT BOTTOM OF END CAP FOR PART NUMBERS ENDING WITH "B"
 STUBS AT TOP OF END CAP FOR PART NUMBERS ENDING WITH "T"
 END CAPS WITH A WELDED CROWN PLATE END WITH "C"
 END CAPS WITH A PREFABRICATED WELDED STUB END WITH "W"

PART #	STUB	B	C
MC3500IEPP06T	6" (150 mm)	33.21" (844 mm)	---
MC3500IEPP06B		---	0.66" (17 mm)
MC3500IEPP08T	8" (200 mm)	31.16" (791 mm)	---
MC3500IEPP08B		---	0.81" (21 mm)
MC3500IEPP10T	10" (250 mm)	29.04" (738 mm)	---
MC3500IEPP10B		---	0.93" (24 mm)
MC3500IEPP12T	12" (300 mm)	26.36" (670 mm)	---
MC3500IEPP12B		---	1.35" (34 mm)
MC3500IEPP15T	15" (375 mm)	23.39" (594 mm)	---
MC3500IEPP15B		---	1.50" (38 mm)
MC3500IEPP18TC	18" (450 mm)	20.03" (509 mm)	---
MC3500IEPP18TW			---
MC3500IEPP18BC			1.77" (45 mm)
MC3500IEPP18BW			---
MC3500IEPP24TC	24" (600 mm)	14.48" (368 mm)	---
MC3500IEPP24TW			---
MC3500IEPP24BC			2.06" (52 mm)
MC3500IEPP24BW			---
MC3500IEPP30BC	30" (750 mm)	---	2.75" (70 mm)

NOTE: ALL DIMENSIONS ARE NOMINAL

MC-SERIES END CAP INSERTION DETAIL

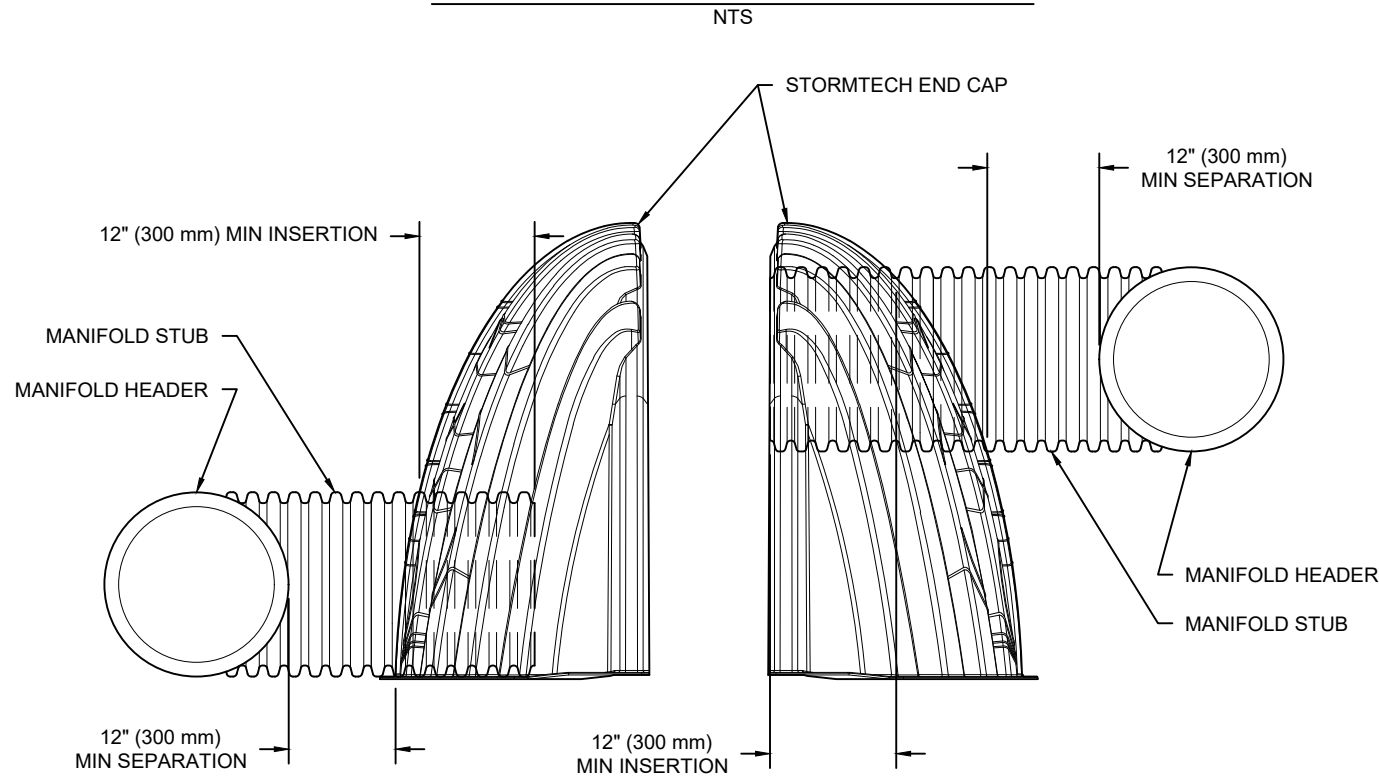

NOTE: MANIFOLD STUB MUST BE LAID HORIZONTAL FOR A PROPER FIT IN END CAP OPENING.

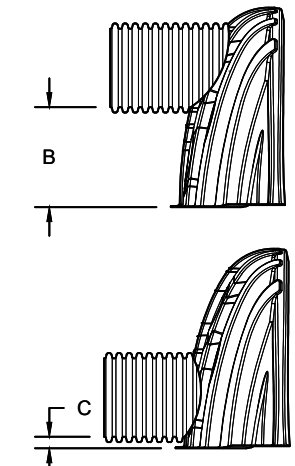

CUSTOM PRECORED INVERTS ARE AVAILABLE UPON REQUEST. INVENTORIED MANIFOLDS INCLUDE 12-24" (300-600 mm) SIZE ON SIZE AND 15-48" (375-1200 mm) ECCENTRIC MANIFOLDS. CUSTOM INVERT LOCATIONS ON THE MC-3500 END CAP CUT IN THE FIELD ARE NOT RECOMMENDED FOR PIPE SIZES GREATER THAN 10" (250 mm). THE INVERT LOCATION IN COLUMN 'B' ARE THE HIGHEST POSSIBLE FOR THE PIPE SIZE.

PALMYRITA AVENUE
 WAREHOUSES NO. 2
 RIVERSIDE, CA

DATE: _____ DRAWN: AS
 PROJECT #: _____ CHECKED: N/A

NO.	DESCRIPTION	DATE	DRW	CHK

StormTech®
 Chamber System

888-892-2694 | WWW.STORMTECH.COM

4640 TRUEMAN BLVD
 HILLIARD, OH 43026
 1-800-733-7473

ADS

THIS DRAWING HAS BEEN PREPARED BASED ON INFORMATION PROVIDED TO ADS UNDER THE DIRECTION OF THE SITE DESIGN ENGINEER OR OTHER PROJECT REPRESENTATIVE. THE SITE DESIGN ENGINEER SHALL REVIEW THIS DRAWING PRIOR TO CONSTRUCTION. IT IS THE ULTIMATE RESPONSIBILITY OF THE SITE DESIGN ENGINEER TO ENSURE THAT THE PRODUCT(S) DEPICTED AND ALL ASSOCIATED DETAILS MEET ALL APPLICABLE LAWS, REGULATIONS, AND PROJECT REQUIREMENTS.

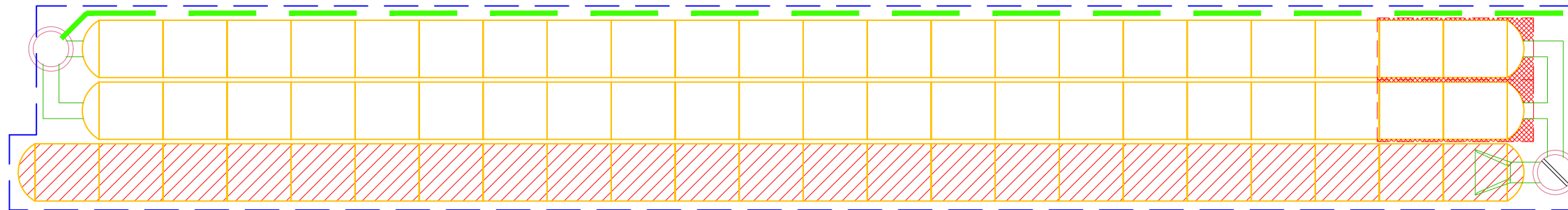

Appendix 7: Hydromodification

Supporting Detail Relating to Hydrologic Conditions of Concern

HCOOC Applicability Map

WQMP Report

County of Riverside Stormwater Project

Santa Ana River Watershed Geodatabase

Report generated: Thu Jul 07 2022 10:19:47 GMT-0700 (Pacific Daylight Time)

Note: The information provided in this report and on the Stormwater Geodatabase for the County of Riverside Stormwater Program is intended to provide basic guidance in the preparation of the applicant's Water Quality Management Plan (WQMP) and should not be relied upon without independent verification. All searches will include any data found within 200 feet of the provided coordinates unless otherwise noted.

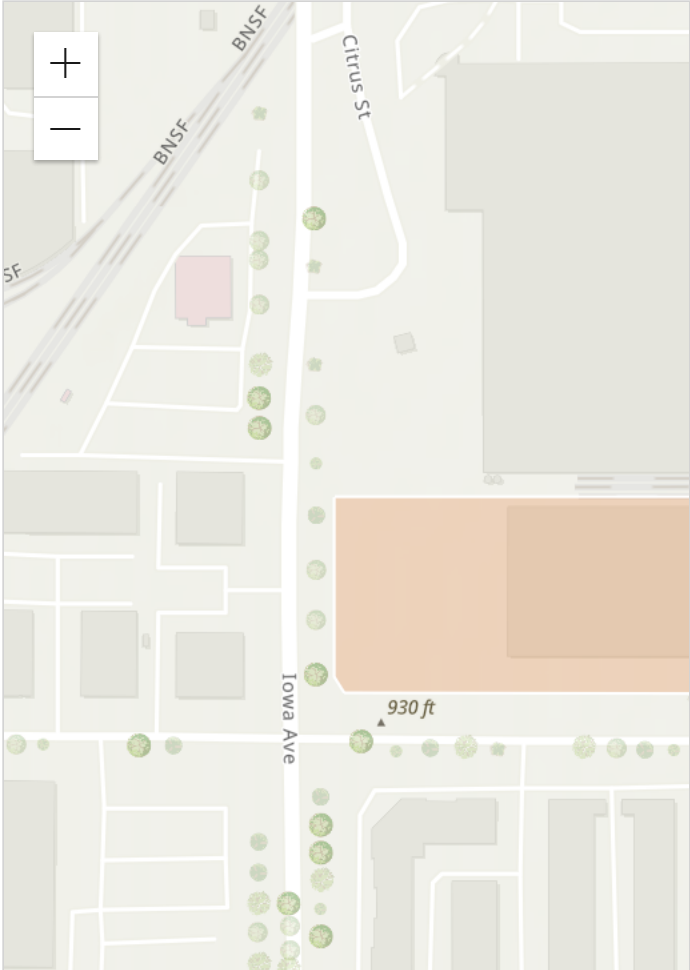
Center Point	34.00581950530195, -117.33695089794539
Map	 <p>Esri, NASA, NGA, USGS, FEMA Esri Co... Powered by Esri</p>
Parcel Number(s)	247170020 , 247140034 , 249060024 , 249060025 , 247170030 , 249040015 , 247170047 , 247170024 , 247170042 , 249060003 , 249060021 , 247170039 ,

[247170023](#), [249060004](#), [247170046](#),
[249060020](#), [247170021](#), [247140009](#),
[247140035](#), [249060033](#)

	<p>247170023, 249060004, 247170046, 249060020, 247170021, 247140009, 247140035, 249060033</p>									
Site Acreage	13.06									
Watershed(s)	SANTA ANA									
Cities (within 1 mile)	RIVERSIDE									
Hydrologic Units	<table border="1"> <thead> <tr> <th data-bbox="829 470 1333 585">HUC Number</th> <th data-bbox="1333 470 1511 585">HUC Name</th> </tr> </thead> <tbody> <tr> <td data-bbox="829 585 1333 856">180702030804</td> <td data-bbox="1333 585 1511 856">East Etiwanda Creek-Santa Ana River</td> </tr> </tbody> </table>		HUC Number	HUC Name	180702030804	East Etiwanda Creek-Santa Ana River				
HUC Number	HUC Name									
180702030804	East Etiwanda Creek-Santa Ana River									
The HUCs Contribute stormwater to the following 303d listed water bodies and TMDLs which may include drainage from your proposed Project Site	<table border="1"> <thead> <tr> <th data-bbox="829 898 1365 1014">WBID Number</th> <th data-bbox="1365 898 1511 1014">WBID Name</th> </tr> </thead> <tbody> <tr> <td data-bbox="829 1014 1365 1247">CAR8012100019990211140353</td> <td data-bbox="1365 1014 1511 1247">Santa Ana River, Reach 3</td> </tr> </tbody> </table>		WBID Number	WBID Name	CAR8012100019990211140353	Santa Ana River, Reach 3				
WBID Number	WBID Name									
CAR8012100019990211140353	Santa Ana River, Reach 3									
These 303d listed water bodies and TMDLs have the following Pollutants of Concern (POC)	<table border="1"> <thead> <tr> <th data-bbox="829 1289 1312 1369">Category</th> <th data-bbox="1312 1289 1511 1369">Pollutants</th> </tr> </thead> <tbody> <tr> <td data-bbox="829 1369 1312 1449">Bacterial Indicators</td> <td data-bbox="1312 1369 1511 1449">Pathogens</td> </tr> <tr> <td data-bbox="829 1449 1312 1528">Metals/Metalloids</td> <td data-bbox="1312 1449 1511 1528">Copper</td> </tr> <tr> <td data-bbox="829 1528 1312 1608">Metals/Metalloids</td> <td data-bbox="1312 1528 1511 1608">Lead</td> </tr> </tbody> </table>		Category	Pollutants	Bacterial Indicators	Pathogens	Metals/Metalloids	Copper	Metals/Metalloids	Lead
Category	Pollutants									
Bacterial Indicators	Pathogens									
Metals/Metalloids	Copper									
Metals/Metalloids	Lead									
Is the Project Site subject to Hydromodification?	NO									
Limitations of Infiltration	<table border="1"> <tr> <td data-bbox="829 1770 1230 1923">Onsite Soils Group(s)</td> <td data-bbox="1230 1770 1511 1923">C _____</td> </tr> <tr> <td data-bbox="829 1923 1230 2022">Known Groundwater Contamination Plumes</td> <td data-bbox="1230 1923 1511 2022">NO</td> </tr> </table>		Onsite Soils Group(s)	C _____	Known Groundwater Contamination Plumes	NO				
Onsite Soils Group(s)	C _____									
Known Groundwater Contamination Plumes	NO									

	(within 1000 ft)										
Environmentally Sensitive Areas within 200 feet	Adjacent Water Wells	NO - Please contact your local water agency for more information.									
	Local Supplier	CITY OF RIVERSIDE W.S.A									
	Wholesale Supplier	METROPOLITAN WATER DISTRICT									
Groundwater Elevation from Mean Sea Level	795 ft.										
85th Percentile Design Storm Depth	0.643 in.										
Groundwater Basin	Riverside-F										
MSHCP / CVMSHCP Criteria Cell(s)	No data										
Retention Ordinance Information	<table border="1"> <thead> <tr> <th data-bbox="829 1556 930 1822">City</th> <th data-bbox="930 1556 1118 1822">Ordinance</th> <th data-bbox="1118 1556 1325 1822">Description</th> <th data-bbox="1325 1556 1507 1822">Storm Event (Required Design Capture Volume)</th> </tr> </thead> <tbody> <tr> <td colspan="4" data-bbox="829 1822 1507 1900">No ordinances found</td> </tr> </tbody> </table>			City	Ordinance	Description	Storm Event (Required Design Capture Volume)	No ordinances found			
	City	Ordinance	Description	Storm Event (Required Design Capture Volume)							
No ordinances found											
Related Studies and Reports	<ul style="list-style-type: none"> IBI Scores - Southern Cal.pdf RiversideBasin.pdf 										

- [bulletin118_4-sc.pdf](#)
- [WaterFacts2022.pdf](#)
- [8039-SAR-Hydromodification.pdf](#)
- [CBRP.pdf](#)
- [University MDP.pdf](#)
- [2012 Annual Report of SAR.pdf](#)

Appendix 8: Source Control

Pollutant Sources/Source Control Checklist

STORMWATER POLLUTANT SOURCES / SOURCE CONTROL CHECKLIST

How to use this worksheet (also see instructions in Section G of the WQMP Template):

1. Review Column 1 and identify which of these potential sources of stormwater pollutants apply to your site. Check each box that applies.
2. Review Column 2 and incorporate all of the corresponding applicable BMPs in your WQMP Exhibit.
3. Review Columns 3 and 4 and incorporate all of the corresponding applicable permanent controls and operational BMPs in your WQMP. Use the format shown in Table G.1 on page 23 of this WQMP Template. Describe your specific BMPs in an accompanying narrative, and explain any special conditions or situations that required omitting BMPs or substituting alternative BMPs for those shown here.

... THEN YOUR WQMP SHOULD INCLUDE THESE SOURCE CONTROL BMPs, AS APPLICABLE			
1	2	3	4
Potential Sources of Runoff Pollutants	Permanent Controls—Show on WQMP Drawings	Permanent Controls—List in WQMP Table and Narrative	Operational BMPs—Include in WQMP Table and Narrative
<input checked="" type="checkbox"/> A. On-site storm drain inlets	<input checked="" type="checkbox"/> Locations of inlets.	<input checked="" type="checkbox"/> Mark all inlets with the words “Only Rain Down the Storm Drain” or similar. Catch Basin Markers may be available from the Riverside County Flood Control and Water Conservation District, call 951.955.1200 to verify.	<input checked="" type="checkbox"/> Maintain and periodically repaint or replace inlet markings. <input checked="" type="checkbox"/> Provide stormwater pollution prevention information to new site owners, lessees, or operators. <input checked="" type="checkbox"/> See applicable operational BMPs in Fact Sheet SC-44, “Drainage System Maintenance,” in the CASQA Stormwater Quality Handbooks at www.cabmphandbooks.com <input checked="" type="checkbox"/> Include the following in lease agreements: “Tenant shall not allow anyone to discharge anything to storm drains or to store or deposit materials so as to create a potential discharge to storm drains.”
<input type="checkbox"/> B. Interior floor drains and elevator shaft sump pumps <input type="checkbox"/> C. Interior parking garages		<input type="checkbox"/> State that interior floor drains and elevator shaft sump pumps will be plumbed to sanitary sewer. <input type="checkbox"/> State that parking garage floor drains will be plumbed to the sanitary sewer.	<input type="checkbox"/> Inspect and maintain drains to prevent blockages and overflow. <input type="checkbox"/> Inspect and maintain drains to prevent blockages and overflow.

STORMWATER POLLUTANT SOURCES / SOURCE CONTROL CHECKLIST

<p>IF THESE SOURCES WILL BE ON THE PROJECT SITE ...</p>	<p align="center">1</p> <p>Potential Sources of Runoff Pollutants</p>	<p align="center">2</p> <p>Permanent Controls—Show on WQMP Drawings</p>	<p align="center">3</p> <p>Permanent Controls—List in WQMP Table and Narrative</p>	<p align="center">4</p> <p>Operational BMPs—Include in WQMP Table and Narrative</p>
<p><input type="checkbox"/> D1. Need for future indoor & structural pest control</p>		<p><input type="checkbox"/> Note building design features that discourage entry of pests.</p>	<p><input type="checkbox"/> Provide Integrated Pest Management information to owners, lessees, and operators.</p>	
<p><input checked="" type="checkbox"/> D2. Landscape/ Outdoor Pesticide Use</p>	<p><input type="checkbox"/> Show locations of native trees or areas of shrubs and ground cover to be undisturbed and retained.</p> <p><input checked="" type="checkbox"/> Show self-retaining landscape areas, if any.</p> <p><input type="checkbox"/> Show stormwater treatment and hydrograph modification management BMPs. (See instructions in Chapter 3, Step 5 and guidance in Chapter 5.)</p>	<p><input type="checkbox"/> State that final landscape plans will accomplish all of the following.</p> <p><input type="checkbox"/> Preserve existing native trees, shrubs, and ground cover to the maximum extent possible.</p> <p><input checked="" type="checkbox"/> Design landscaping to minimize irrigation and runoff, to promote surface infiltration where appropriate, and to minimize the use of fertilizers and pesticides that can contribute to stormwater pollution.</p> <p><input checked="" type="checkbox"/> Where landscaped areas are used to retain or detain stormwater, specify plants that are tolerant of saturated soil conditions.</p> <p><input checked="" type="checkbox"/> Consider using pest-resistant plants, especially adjacent to hardscape.</p> <p>To insure successful establishment, select plants appropriate to site soils, slopes, climate, sun, wind, rain, land use, air movement, ecological consistency, and plant interactions.</p>	<p><input checked="" type="checkbox"/> Maintain landscaping using minimum or no pesticides.</p> <p><input checked="" type="checkbox"/> See applicable operational BMPs in “What you should know for....Landscape and Gardening” at http://rcflood.org/stormwater/Error Hyperlink reference not valid.</p> <p><input checked="" type="checkbox"/> Provide IPM information to new owners, lessees and operators.</p>	

STORMWATER POLLUTANT SOURCES / SOURCE CONTROL CHECKLIST

... THEN YOUR WQMP SHOULD INCLUDE THESE SOURCE CONTROL BMPs, AS APPLICABLE			
1	2	3	4
IF THESE SOURCES WILL BE ON THE PROJECT SITE ...	Permanent Controls—Show on WQMP Drawings	Permanent Controls—List in WQMP Table and Narrative	Operational BMPs—Include in WQMP Table and Narrative
<p><input type="checkbox"/> E. Pools, spas, ponds, decorative fountains, and other water features.</p>	<p><input type="checkbox"/> Show location of water feature and a sanitary sewer cleanout in an accessible area within 10 feet. (Exception: Public pools must be plumbed according to County Department of Environmental Health Guidelines.)</p>	<p>If the Co-Permittee requires pools to be plumbed to the sanitary sewer, place a note on the plans and state in the narrative that this connection will be made according to local requirements.</p>	<p><input type="checkbox"/> See applicable operational BMPs in "Guidelines for Maintaining Your Swimming Pool, Jacuzzi and Garden Fountain" at http://rcflood.org/stormwater/</p>
<p><input type="checkbox"/> F. Food service</p>	<p><input type="checkbox"/> For restaurants, grocery stores, and other food service operations, show location (indoors or in a covered area outdoors) of a floor sink or other area for cleaning floor mats, containers, and equipment.</p> <p><input type="checkbox"/> On the drawing, show a note that this drain will be connected to a grease interceptor before discharging to the sanitary sewer.</p>	<p><input type="checkbox"/> Describe the location and features of the designated cleaning area.</p> <p><input type="checkbox"/> Describe the items to be cleaned in this facility and how it has been sized to insure that the largest items can be accommodated.</p>	<p><input type="checkbox"/> See the brochure, "The Food Service Industry Best Management Practices for: Restaurants, Grocery Stores, Delicatessens and Bakeries" at http://rcflood.org/stormwater/</p> <p>Provide this brochure to new site owners, lessees, and operators.</p>
<p><input type="checkbox"/> G. Refuse areas</p>	<p><input checked="" type="checkbox"/> Show where site refuse and recycled materials will be handled and stored for pickup. See local municipal requirements for sizes and other details of refuse areas.</p> <p><input type="checkbox"/> If dumpsters or other receptacles are outdoors, show how the designated area will be covered, graded, and paved to prevent runoff and show locations of berms to prevent runoff from the area.</p> <p><input type="checkbox"/> Any drains from dumpsters, compactors, and tallow bin areas shall be connected to a grease removal device before discharge to sanitary sewer.</p>	<p><input checked="" type="checkbox"/> State how site refuse will be handled and provide supporting detail to what is shown on plans.</p> <p><input checked="" type="checkbox"/> State that signs will be posted on or near dumpsters with the words "Do not dump hazardous materials here" or similar.</p>	<p><input checked="" type="checkbox"/> State how the following will be implemented:</p> <p>Provide adequate number of receptacles. Inspect receptacles regularly; repair or replace leaky receptacles. Keep receptacles covered. Prohibit/prevent dumping of liquid or hazardous wastes. Post "no hazardous materials" signs. Inspect and pick up litter daily and clean up spills immediately. Keep spill control materials available on-site. See Fact Sheet SC-34, "Waste Handling and Disposal" in the CASQA Stormwater Quality Handbooks at www.cabmphandbooks.com</p>

STORMWATER POLLUTANT SOURCES/SOURCE CONTROL CHECKLIST

<p>IF THESE SOURCES WILL BE ON THE PROJECT SITE ...</p>	<p align="center">... THEN YOUR WQMP SHOULD INCLUDE THESE SOURCE CONTROL BMPs, AS APPLICABLE</p>			
<p>1 <input type="checkbox"/> H. Industrial processes.</p>	<p align="center">2</p> <p>Permanent Controls—Show on WQMP Drawings</p> <p><input type="checkbox"/> Show process area.</p>	<p align="center">3</p> <p>Permanent Controls—List in WQMP Table and Narrative</p> <p><input type="checkbox"/> If industrial processes are to be located on site, state: “All process activities to be performed indoors. No processes to drain to exterior or to storm drain system.”</p>	<p align="center">4</p> <p>Operational BMPs—Include in WQMP Table and Narrative</p> <p><input type="checkbox"/> See Fact Sheet SC-10, “Non-Stormwater Discharges” in the CASQA Stormwater Quality Handbooks at www.cabmphandbooks.com See the brochure “Industrial & Commercial Facilities Best Management Practices for: Industrial, Commercial Facilities” at http://rcflood.org/stormwater/</p>	

STORMWATER POLLUTANT SOURCES / SOURCE CONTROL CHECKLIST

IF THESE SOURCES WILL BE ON THE PROJECT SITE THEN YOUR WQMP SHOULD INCLUDE THESE SOURCE CONTROL BMPs, AS APPLICABLE		
1 Potential Sources of Runoff Pollutants	2 Permanent Controls—Show on WQMP Drawings	3 Permanent Controls—List in WQMP Table and Narrative	4 Operational BMPs—Include in WQMP Table and Narrative
<input type="checkbox"/> I. Outdoor storage of equipment or materials. (See rows J and K for source control measures for vehicle cleaning, repair, and maintenance.)	<input type="checkbox"/> Show any outdoor storage areas, including how materials will be covered. Show how areas will be graded and bermed to prevent runoff or run-off from area. <input type="checkbox"/> Storage of non-hazardous liquids shall be covered by a roof and/or drain to the sanitary sewer system, and be contained by berms, dikes, liners, or vaults. <input type="checkbox"/> Storage of hazardous materials and wastes must be in compliance with the local hazardous materials ordinance and a Hazardous Materials Management Plan for the site.	<p>Include a detailed description of materials to be stored, storage areas, and structural features to prevent pollutants from entering storm drains.</p> <p>Where appropriate, reference documentation of compliance with the requirements of Hazardous Materials Programs for:</p> <ul style="list-style-type: none"> ▪ Hazardous Waste Generation ▪ Hazardous Materials Release Response and Inventory ▪ California Accidental Release (CalARP) ▪ Aboveground Storage Tank ▪ Uniform Fire Code Article 80 Section 103(b) & (c) 1991 ▪ Underground Storage Tank <p>www.cchealth.org/groups/hazmat /</p>	<input type="checkbox"/> See the Fact Sheets SC-31, “Outdoor Liquid Container Storage” and SC-33, “Outdoor Storage of Raw Materials” in the CASQA Stormwater Quality Handbooks at www.cabmphandbooks.com

STORMWATER POLLUTANT SOURCES / SOURCE CONTROL CHECKLIST

<p align="center">IF THESE SOURCES WILL BE ON THE PROJECT SITE ...</p>	<p align="center">... THEN YOUR WQMP SHOULD INCLUDE THESE SOURCE CONTROL BMPs, AS APPLICABLE</p>		
<p align="center">1 Potential Sources of Runoff Pollutants</p>	<p align="center">2 Permanent Controls—Show on WQMP Drawings</p>	<p align="center">3 Permanent Controls—List in WQMP Table and Narrative</p>	<p align="center">4 Operational BMPs—Include in WQMP Table and Narrative</p>
<p><input type="checkbox"/> J. Vehicle and Equipment Cleaning</p>	<p><input type="checkbox"/> Show on drawings as appropriate: (1) Commercial/industrial facilities having vehicle/equipment cleaning needs shall either provide a covered, bermed area for washing activities or discourage vehicle/equipment washing by removing hose bibs and installing signs prohibiting such uses. (2) Multi-dwelling complexes shall have a paved, bermed, and covered car wash area (unless car washing is prohibited on-site and hoses are provided with an automatic shut-off to discourage such use). (3) Washing areas for cars, vehicles, and equipment shall be paved, designed to prevent run-on to or runoff from the area, and plumbed to drain to the sanitary sewer. (4) Commercial car wash facilities shall be designed such that no runoff from the facility is discharged to the storm drain system. Wastewater from the facility shall discharge to the sanitary sewer, or a wastewater reclamation system shall be installed.</p>	<p><input type="checkbox"/> If a car wash area is not provided, describe any measures taken to discourage on-site car washing and explain how these will be enforced.</p>	<p>Describe operational measures to implement the following (if applicable):</p> <p><input type="checkbox"/> Washwater from vehicle and equipment washing operations shall not be discharged to the storm drain system. Refer to “Outdoor Cleaning Activities and Professional Mobile Service Providers” for many of the Potential Sources of Runoff Pollutants categories below. Brochure can be found at http://rcflood.org/stormwater/</p> <p><input type="checkbox"/> Car dealerships and similar may rinse cars with water only.</p>

STORMWATER POLLUTANT SOURCES / SOURCE CONTROL CHECKLIST

<p align="center">1</p> <p align="center">Potential Sources of Runoff Pollutants</p>	<p align="center">2</p> <p align="center">Permanent Controls—Show on WQMP Drawings</p>	<p align="center">3</p> <p align="center">Permanent Controls—List in WQMP Table and Narrative</p>	<p align="center">4</p> <p align="center">Operational BMPs—Include in WQMP Table and Narrative</p>
<p><input type="checkbox"/> K. Vehicle/Equipment Repair and Maintenance</p>	<p><input type="checkbox"/> Accommodate all vehicle equipment repair and maintenance indoors. Or designate an outdoor work area and design the area to prevent run-on and runoff of stormwater.</p> <p><input type="checkbox"/> Show secondary containment for exterior work areas where motor oil, brake fluid, gasoline, diesel fuel, radiator fluid, acid-containing batteries or other hazardous materials or hazardous wastes are used or stored. Drains shall not be installed within the secondary containment areas.</p> <p><input type="checkbox"/> Add a note on the plans that states either (1) there are no floor drains, or (2) floor drains are connected to wastewater pretreatment systems prior to discharge to the sanitary sewer and an industrial waste discharge permit will be obtained.</p>	<p><input type="checkbox"/> State that no vehicle repair or maintenance will be done outdoors, or else describe the required features of the outdoor work area.</p> <p><input type="checkbox"/> State that there are no floor drains or if there are floor drains, note the agency from which an industrial waste discharge permit will be obtained and that the design meets that agency's requirements.</p> <p><input type="checkbox"/> State that there are no tanks, containers or sinks to be used for parts cleaning or rinsing or, if there are, note the agency from which an industrial waste discharge permit will be obtained and that the design meets that agency's requirements.</p>	<p>In the Stormwater Control Plan, note that all of the following restrictions apply to use the site:</p> <p><input type="checkbox"/> No person shall dispose of, nor permit the disposal, directly or indirectly of vehicle fluids, hazardous materials, or rinsewater from parts cleaning into storm drains.</p> <p><input type="checkbox"/> No vehicle fluid removal shall be performed outside a building, nor on asphalt or ground surfaces, whether inside or outside a building, except in such a manner as to ensure that any spilled fluid will be in an area of secondary containment. Leaking vehicle fluids shall be contained or drained from the vehicle immediately.</p> <p><input type="checkbox"/> No person shall leave unattended drip parts or other open containers containing vehicle fluid, unless such containers are in use or in an area of secondary containment.</p> <p>Refer to "Automotive Maintenance & Car Care Best Management Practices for Auto Body Shops, Auto Repair Shops, Car Dealerships, Gas Stations and Fleet Service Operations". Brochure can be found at http://rcflood.org/stormwater/</p> <p>Refer to Outdoor Cleaning Activities and Professional Mobile Service Providers for many of the Potential Sources of Runoff Pollutants categories below. Brochure can be found at http://rcflood.org/stormwater/</p>

STORMWATER POLLUTANT SOURCES / SOURCE CONTROL CHECKLIST

IF THESE SOURCES WILL BE ON THE PROJECT SITE THEN YOUR WQMP SHOULD INCLUDE THESE SOURCE CONTROL BMPs, AS APPLICABLE		
1 Potential Sources of Runoff Pollutants	2 Permanent Controls—Show on WQMP Drawings	3 Permanent Controls—List in WQMP Table and Narrative	4 Operational BMPs—Include in WQMP Table and Narrative
<input type="checkbox"/> L. Fuel Dispensing Areas	<input type="checkbox"/> Fueling areas ⁶ shall have impermeable floors (i.e., portland cement concrete or equivalent smooth impervious surface) that are: a) graded at the minimum slope necessary to prevent ponding; and b) separated from the rest of the site by a grade break that prevents run-on of stormwater to the maximum extent practicable. <input type="checkbox"/> Fueling areas shall be covered by a canopy that extends a minimum of ten feet in each direction from each pump. [Alternative: The fueling area must be covered and the cover's minimum dimensions must be equal to or greater than the area within the grade break or fuel dispensing area ¹ .] The canopy [or cover] shall not drain onto the fueling area.		<input type="checkbox"/> The property owner shall dry sweep the fueling area routinely. <input type="checkbox"/> See the Fact Sheet SD-30, "Fueling Areas" in the CASQA Stormwater Quality Handbooks at www.cabmphandbooks.com

⁶ The fueling area shall be defined as the area extending a minimum of 6.5 feet from the corner of each fuel dispenser or the length at which the hose and nozzle assembly may be operated plus a minimum of one foot, whichever is greater.

STORMWATER POLLUTANT SOURCES / SOURCE CONTROL CHECKLIST

<p>IF THESE SOURCES WILL BE ON THE PROJECT SITE ...</p>	<p align="center">... THEN YOUR WQMP SHOULD INCLUDE THESE SOURCE CONTROL BMPs, AS APPLICABLE</p>		
<p>1 Potential Sources of Runoff Pollutants</p>	<p align="center">2 Permanent Controls—Show on WQMP Drawings</p>	<p align="center">3 Permanent Controls—List in WQMP Table and Narrative</p>	<p align="center">4 Operational BMPs—Include in WQMP Table and Narrative</p>
<p><input type="checkbox"/> M. Loading Docks</p>	<p><input type="checkbox"/> Show a preliminary design for the loading dock area, including roofing and drainage. Loading docks shall be covered and/or graded to minimize run-on to and runoff from the loading area. Roof downspouts shall be positioned to direct stormwater away from the loading area. Water from loading dock areas shall be drained to the sanitary sewer, or diverted and collected for ultimate discharge to the sanitary sewer.</p> <p><input type="checkbox"/> Loading dock areas draining directly to the sanitary sewer shall be equipped with a spill control valve or equivalent device, which shall be kept closed during periods of operation.</p> <p><input type="checkbox"/> Provide a roof overhang over the loading area or install door skirts (cowling) at each bay that enclose the end of the trailer.</p>		<p><input type="checkbox"/> Move loaded and unloaded items indoors as soon as possible.</p> <p><input type="checkbox"/> See Fact Sheet SC-30, “Outdoor Loading and Unloading,” in the CASQA Stormwater Quality Handbooks at www.cabmphandbooks.com</p>

STORMWATER POLLUTANT SOURCES / SOURCE CONTROL CHECKLIST

<p>IF THESE SOURCES WILL BE ON THE PROJECT SITE ...</p>	<p align="center">... THEN YOUR WQMP SHOULD INCLUDE THESE SOURCE CONTROL BMPs, AS APPLICABLE</p>		
<p>1 Potential Sources of Runoff Pollutants</p>	<p align="center">2 Permanent Controls—Show on WQMP Drawings</p>	<p align="center">3 Permanent Controls—List in WQMP Table and Narrative</p>	<p align="center">4 Operational BMPs—Include in WQMP Table and Narrative</p>
<p><input type="checkbox"/> N. Fire Sprinkler Test Water</p>		<p><input type="checkbox"/> Provide a means to drain fire sprinkler test water to the sanitary sewer.</p>	<p><input type="checkbox"/> See the note in Fact Sheet SC-41, “Building and Grounds Maintenance,” in the CASQA Stormwater Quality Handbooks at www.cabmphandbooks.com</p>
<p><input type="checkbox"/> O. Miscellaneous Drain or Wash Water or Other Sources</p> <p><input type="checkbox"/> Boiler drain lines</p> <p><input checked="" type="checkbox"/> Condensate drain lines</p> <p><input type="checkbox"/> Rooftop equipment</p> <p><input type="checkbox"/> Drainage sumps</p> <p><input type="checkbox"/> Roofing, gutters, and trim.</p> <p><input type="checkbox"/> Other sources</p>		<p><input type="checkbox"/> Boiler drain lines shall be directly or indirectly connected to the sanitary sewer system and may not discharge to the storm drain system.</p> <p><input checked="" type="checkbox"/> Condensate drain lines may discharge to landscaped areas if the flow is small enough that runoff will not occur. Condensate drain lines may not discharge to the storm drain system.</p> <p><input type="checkbox"/> Rooftop equipment with potential to produce pollutants shall be roofed and/or have secondary containment.</p> <p><input type="checkbox"/> Any drainage sumps on-site shall feature a sediment sump to reduce the quantity of sediment in pumped water.</p> <p><input type="checkbox"/> Avoid roofing, gutters, and trim made of copper or other unprotected metals that may leach into runoff.</p> <p><input type="checkbox"/> Include controls for other sources as specified by local reviewer.</p>	

STORMWATER POLLUTANT SOURCES/SOURCE CONTROL CHECKLIST

IF THESE SOURCES WILL BE ON THE PROJECT SITE THEN YOUR WQMP SHOULD INCLUDE THESE SOURCE CONTROL BMPs, AS APPLICABLE			
1 Potential Sources of Runoff Pollutants	2 Permanent Controls—Show on WQMP Drawings	3 Permanent Controls—List in WQMP Table and Narrative	4 Operational BMPs—Include in WQMP Table and Narrative	
<input checked="" type="checkbox"/> P. Plazas, sidewalks, and parking lots.			<input checked="" type="checkbox"/> Sweep plazas, sidewalks, and parking lots regularly to prevent accumulation of litter and debris. Collect debris from pressure washing to prevent entry into the storm drain system. Collect washwater containing any cleaning agent or degreaser and discharge to the sanitary sewer not to a storm drain.	

Appendix 9: O&M

Operation and Maintenance Plan and Documentation of Finance, Maintenance and Recording Mechanisms

Appendix 10: Educational Materials

BMP Fact Sheets, Maintenance Guidelines and Other End-User BMP Information

10 Ways to **Save** Water Outdoors

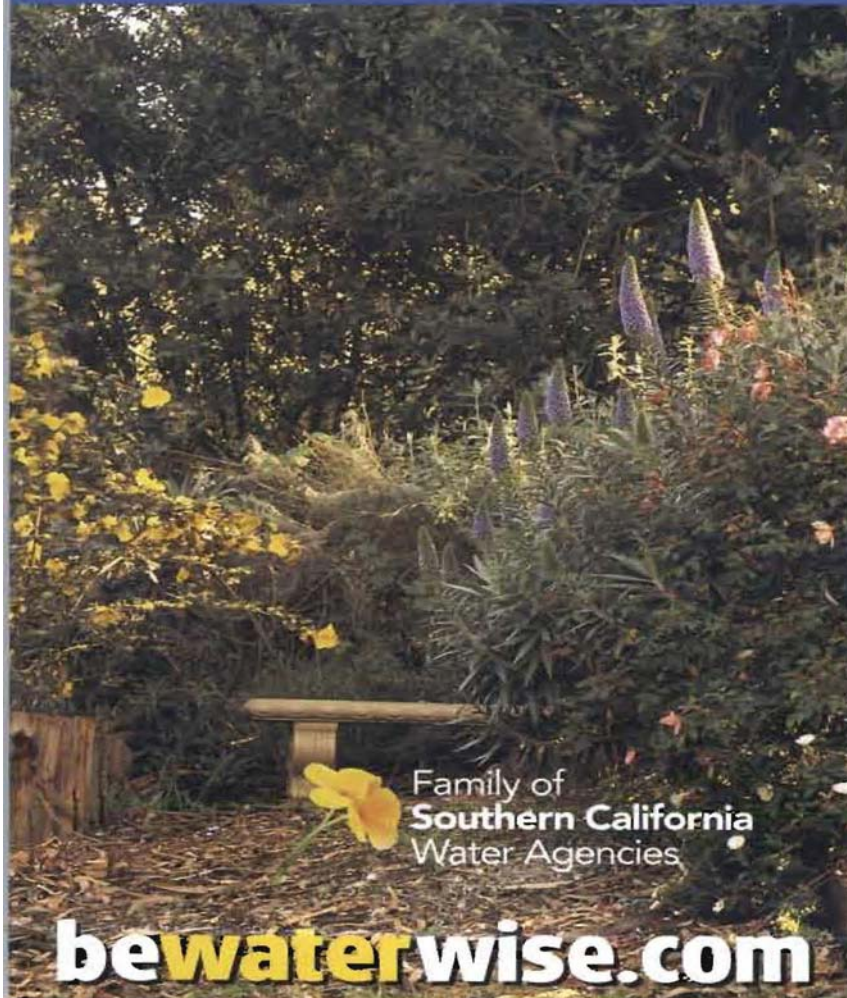

Family of
Southern California
Water Agencies

bewaterwise.com

TIP #1 The average homeowner uses twice the amount of water needed to keep plants healthy. Use the watering calculator and index at bewaterwise.com to know exactly how much water your plants need.

TIP #2 Check your sprinkler system for leaks, overspray and broken sprinkler heads. Update with drip or other more water-efficient sprinklers where appropriate.

TIP #3 This fall, plant a portion of your garden with beautiful native and California Friendly plants. Browse the plant database at bewaterwise.com to find just the right look for your outdoor spaces.

TIP #4 Reduce the amount of water-thirsty grass. Keep only what you need and replace the rest with less-thirsty plants or permeable paving.

TIP #5 For the grass you keep, set your lawnmower blade higher.

TIP #6 Adjust your sprinkler timer downward in September. Plants need less water when days are shorter.

TIP #7 Use a broom instead of the hose for cleaning sidewalks and patios.

TIP #8 Mulch! A layer of bark, gravel, compost, sawdust or low-growing groundcover evens out soil temperature and allows better water retention.

TIP #9 Check the list of invasive plants that hurt our environment at caleppc.org and remove any from your garden.

TIP #10 Share these tips with your gardener, neighbors and friends. Water conservation should be a part of every Southern Californian's lifestyle, but that doesn't mean we can't have lush and beautiful outdoor spaces.

bewaterwise.com

For Information:

LOCAL SEWERING AGENCIES IN RIVERSIDE COUNTY:

City of Beaumont	(909) 769-8520
Belair Homeowners Association	(909) 277-1414
City of Banning	(909) 922-3130
City of Blythe	(760) 922-6161
City of Coachella	(760) 391-5008
Coachella Valley Water District	(760) 398-2651
City of Corona	(909) 736-2259
Desert Center, CSA #51	(760) 227-3203
Eastern Municipal Water District	(909) 928-3777
Elsinore Valley MWD	(909) 674-3146
Farm Mutual Water Company	(909) 244-4198
Idyllwild Water District	(909) 659-2143
Jurupa Community Services Dist.	(909) 685-7434
Lake Hemet MWD	(909) 658-3241
Lee Lake Water District	(909) 277-1414
March Air Force Base	(909) 656-7000
Mission Springs Water District	(760) 329-6448
City of Palm Springs	(760) 323-8242
Rancho Caballero	(909) 780-9272
Rancho California Water Dist.	(909) 676-4101
Ripley, CSA #62	(760) 922-4909
Rubidoux Community Services Dist.	(909) 684-7580
City of Riverside	(909) 782-5341
Silent Valley Club, Inc	(909) 849-4501
Valley Sanitary District	(760) 347-2356
Western Municipal Water District	(909) 780-4170

SPILL RESPONSE AGENCY:

HAZ-MAT: (909) 358-5055

HAZARDOUS WASTE DISPOSAL: (909) 358-5055

TO REPORT ILLEGAL DUMPING OR A CLOGGED

STORM DRAIN: 1-800-506-2555



Storm Water Clean Water

PROTECTION PROGRAM

Riverside County gratefully acknowledges the Bay Area Stormwater Management Agencies Association and the Cleaning Equipment Trade Association for information provided in this brochure.

StormWater Pollution

What you should know for...

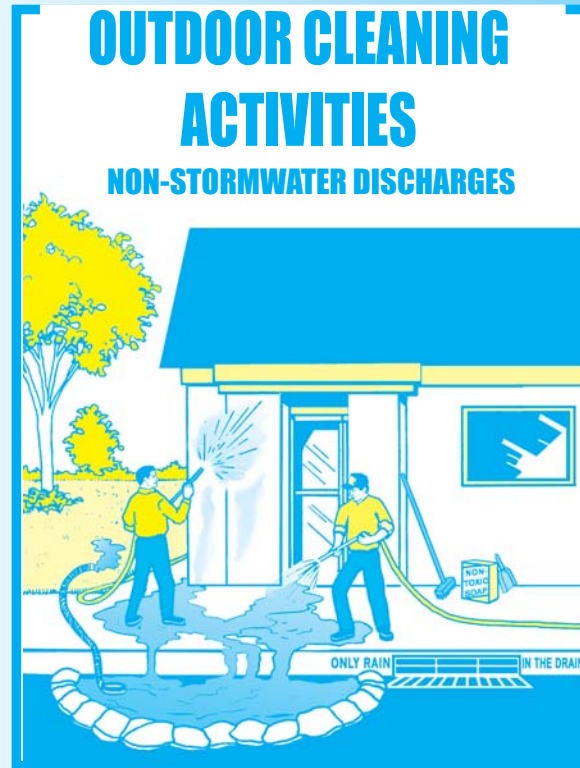

GUIDELINES for disposal of washwater from:

- Sidewalk, plaza or parking lot cleaning
- Vehicle washing or detailing
- Building exterior cleaning
- Waterproofing
- Equipment cleaning or degreasing

Do you know . . . where the water should go?



Riverside County has two drainage systems - sanitary sewers and storm drains. The storm drain system is designed to prevent flooding by carrying excess rainwater away from streets. . . it's not designed to be a waste disposal system. Since the storm drain system does not provide for water treatment, it often serves the unintended function of transporting pollutants directly to our waterways.

Unlike sanitary sewers, storm drains are not connected to a treatment plant - they flow directly to our local streams, rivers and lakes.

Soaps, degreasers, automotive fluids, litter, and a host of other materials washed off buildings, sidewalks, plazas, parking areas, vehicles, and equipment can all pollute our waterways.

Non-stormwater discharges such as washwater generated from outdoor cleaning projects often transport harmful pollutants into storm drains and our local waterways. Polluted runoff contaminates local waterways and poses a threat to groundwater resources.

The Cities and County of Riverside StormWater/CleanWater Protection Program

Since preventing pollution is much easier, and less costly than cleaning up "after the fact," the Cities and County of Riverside StormWater/CleanWater Protection Program informs residents and businesses of pollution prevention activities such as those described in this pamphlet.

The Cities and County of Riverside have adopted ordinances for stormwater management and discharge control. In accordance with state and federal law, these local stormwater ordinances **prohibit** the discharge of wastes into the storm drain system or local surface waters. This includes non-stormwater discharges containing oil, grease, detergents, degreasers, trash, or other waste materials.



PLEASE NOTE: The discharge of pollutants into the street, gutters, storm drain system, or waterways - without a Regional Water Quality Control Board permit or waiver - is **strictly prohibited** by local ordinances and state and federal law.

Help Protect Our Waterways!

Use These Guidelines For Outdoor Cleaning Activities and Washwater Disposal

DO . . . Dispose of **small amounts** of washwater from cleaning **building exteriors, sidewalks, or plazas** onto landscaped or unpaved surfaces provided you have the owner's permission and the discharge will not cause flooding or nuisance problems, or flow into a storm drain.

DO NOT . . . Discharge **large amounts** of these types of washwater onto landscaped areas or soil where water may run to a street or storm drain. Wastewater from exterior cleaning may be pumped to a sewer line with specific permission from the local sewerage agency.

DO . . . Check with your local sewerage agency's policies and requirements concerning waste water disposal. **Water from many outdoor cleaning activities** may be acceptable for disposal to the sewer system. See the list on the back of this flyer for phone numbers of the sewerage agencies in your area.

DO NOT . . . Pour **hazardous wastes** or toxic materials into the storm drain or sewer system . . . properly dispose of it instead. When in doubt, contact the local sewerage agency! The agency will tell you what types of liquid wastes can be accepted.

DO . . . Understand that **water (without soap)** used to remove dust from clean vehicles may be discharged to a street or storm drain. **Washwater from sidewalk, plaza, and building surface cleaning** may go into a street or storm drain if ALL of the following conditions are met:

- 1) The surface being washed is free of residual oil stains, debris and similar pollutants by using dry cleanup methods (sweeping, and cleaning any oil or chemical spills with rags or other absorbent materials before using water).
- 2) Washing is done with water only - no soap or other cleaning materials.
- 3) You have not used the water to remove paint from surfaces during cleaning.

DO NOT . . . Dispose of water containing **soap or any other type of cleaning agent** into a storm drain or water body. This is a direct violation of state and/or local regulations. Because **wastewater from cleaning parking areas or roadways** normally contains metallic brake pad dust, oil and other automotive fluids, it should never be discharged to a street, gutter, or storm drain.

DO . . . Understand that **mobile auto detailers** should divert washwater to landscaped or dirt areas. Note: Be aware that soapy washwater may adversely affect landscaping; consult with the property owner. Residual washwater may remain on paved surfaces to evaporate; sweep up any remaining residue. If there is sufficient water volume to reach the storm drain, collect the runoff and obtain permission to pump it into the sanitary sewer. Follow local sewerage agency's requirements for disposal.

DO NOT . . . Dispose of left over cleaning agents into the gutter, storm drain or sanitary sewer.

Regarding Cleaning Agents:

If you must use soap, use biodegradable/phosphate free cleaners. Avoid use of petroleum based cleaning products. Although the use of nontoxic cleaning products is strongly encouraged, do understand that these products can still degrade water quality and, therefore, the discharge of these products into

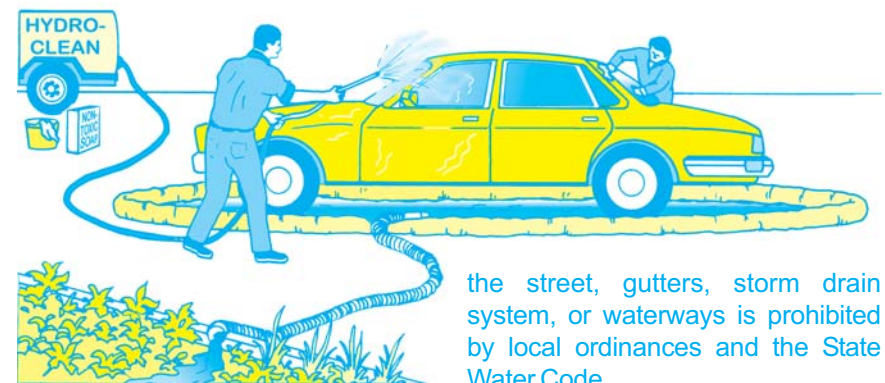

the street, gutters, storm drain system, or waterways is prohibited by local ordinances and the State Water Code.

Note: When cleaning surfaces with a high pressure washer or steam cleaning methods, additional precautions should be taken to prevent the discharge of pollutants into the storm drain system. These two methods of surface cleaning, as compared to the use of a low pressure hose, can remove additional materials that can contaminate local waterways.

OTHER TIPS TO HELP PROTECT OUR WATER . . .

SCREENING WASH WATER

A thorough dry cleanup before washing (without soap) surfaces such as building exteriors and decks without loose paint, sidewalks, or plaza areas, *should be sufficient to protect storm drains*. **However**, if any debris (solids) could enter storm drains or remain in the gutter or street after cleaning, washwater should first pass through a "20 mesh" or finer screen to catch the solid material, which should then be disposed of in the trash.

DRAIN INLET PROTECTION/CONTAINING & COLLECTING WASH WATER

- Sand bags can be used to create a barrier around storm drain inlets.
- Plugs or rubber mats can be used to temporarily seal storm drain openings.
- You can also use vacuum booms, containment pads, or temporary berms to keep wash water away from the street, gutter, or storm drain.

EQUIPMENT AND SUPPLIES

Special materials such as absorbents, storm drain plugs and seals, small sump pumps, and vacuum booms are available from many vendors. For more information check catalogs such as New Pig (800-468-4647), Lab Safety Supply (800-356-0783), C&H (800-558-9966), and W.W. Grainger (800-994-9174); or call the Cleaning Equipment Trade Association (800-441-0111) or the Power Washers of North America (800-393-PWNA).

For Information:

For information on “closed-loop” suppliers and recycling/disposal vendors, contact:
County of Riverside
Health Services Agency
Department of Environmental Health
at (909) 358-5055.

SPILL RESPONSE AGENCY:

HAZ-MAT: (909) 358-5055
AFTER 5:00 P.M.: (909) 358-5245 OR 911

RECYCLING AND HAZARDOUS WASTE

DISPOSAL: (909) 358-5055

TO REPORT ILLEGAL DUMPING OR A
CLOGGED STORM DRAIN: 1-800-506-2555

To order additional brochures or to obtain information on other pollution prevention activities, call: (909) 955-1111.

The Cities and County of Riverside
StormWater/CleanWater Protection Program

1-800-506-2555



Riverside County gratefully acknowledges the Santa Clara Valley Nonpoint Source Pollution Control Program and the City of Los Angeles Stormwater Management Division for information provided in this brochure.

StormWater Pollution

What you should know for...

AUTOMOTIVE MAINTENANCE & CAR CARE



Best Management Practices (BMPS) for:

- Auto Body Shops
- Auto Repair Shops
- Car Dealerships
- Gas Stations
- Fleet Service Operations

StormWater Pollution . . . What You Should Know

Riverside County has two drainage systems - sanitary sewers and storm drains. The storm drain system is designed to help prevent flooding by carrying excess rainwater away from streets. Since the storm drain system does not provide for water treatment, it also serves the *unintended* function of transporting pollutants directly to our waterways.

Unlike sanitary sewers, storm drains are not connected to a treatment plant - they flow directly to our local streams, rivers and lakes.

Rain and water runoff from automotive shops and businesses can carry pollutant material into storm drains. Examples of pollutants include oil and grease from cars, copper and asbestos from worn brake linings, zinc from tires, and toxics from spilled fluids.

Stormwater pollution causes as much as 60% of our water pollution problem. It jeopardizes the quality of our waterways and poses a threat to groundwater resources if pollutants percolate through soil.



The Cities and County of Riverside StormWater/CleanWater Protection Program

Since preventing pollution is much easier, and less costly, than cleaning up “after the fact,” the Cities and County of Riverside StormWater/CleanWater Protection Program informs residents and businesses on pollution prevention activities such as the Best Management Practices (BMPs) described in this pamphlet.

The Cities and County of Riverside have adopted ordinances for stormwater management and discharge control. In accordance with state and federal law, these local stormwater ordinances **prohibit** the discharge of wastes into the storm drain system or local surface waters. This includes discharges containing oil, antifreeze, gasoline and other waste materials.

PLEASE NOTE: A common stormwater pollution problem associated with automotive shops and businesses is the hosing down of service bays, parking and other areas. Often, this activity flushes pollutants into the storm drain system. The discharges of pollutants is **strictly prohibited** by local ordinances and state and federal regulations.

Keep your shop in tune. Follow these Practices to help prevent stormwater pollution . . .

1. Changing Automotive Fluids

- Designate an area away from storm or sanitary drains to change automotive fluids.
- Collect, separate, and recycle motor oil, antifreeze, transmission fluid, and gear oil.
- Drain brake fluid and other non-recyclables into a proper container and handle as a hazardous waste.
- Use a radiator flushing fluid that can be recycled, and add it to the waste antifreeze.

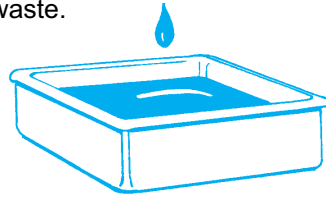

2. Working on Transmissions, Engines, and Miscellaneous Repairs

- Keep a drip pan or a wide low-rimmed container under vehicles to catch fluids whenever you unclip hoses, unscrew filters, or change parts, to contain unexpected leaks.

3. Preventing Leaks and Spills

- Avoid spills by emptying and wiping drip pans when you move them to another vehicle or when they are half-full.
- Routinely check equipment to wipe up spills and repair leaks.
- Place large pans or an inflatable portable berm under wrecked cars.
- Drain all fluids from wrecked vehicles or "parts" cars you keep on site.

4. Cleaning up Spills

- Clean up small spills immediately using shop rags.



- Keep dry absorbent materials and/or a wet/dry vacuum cleaner on hand for mid-sized spills.
- Contain large spills immediately; block or shut off floor and parking lot drains and notify the authorities.
- Train employees to be familiar with hazardous spill response plans and emergency procedures.

5. Identify and Control Wastewater Discharges

- Ensure that shop sinks and floor drains are connected to the sanitary sewer. Check with the local sewer authority regarding permitting or other requirements.
- Post signs to prevent disposal of liquid wastes into sanitary drains.

6. Fueling Vehicles

- Clean-up minor spills, with a dry absorbent, rather than allowing them to evaporate. Dispose of the absorbent as a dry hazardous waste.
- Use a damp cloth and a damp mop to keep the area clean rather than a hose or a wet mop.

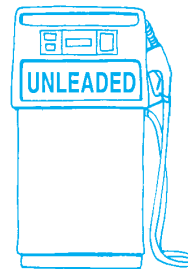

7. Removing and Storing Batteries

- Store batteries indoors, on an open rack.
- Return used batteries to a battery vendor.
- Contain cracked batteries to prevent hazardous spills.

8. Cleaning Parts

- Clean parts in a self-contained unit, solvent sink, or parts washer to prevent solvents and grease from entering a sewer or storm drain connection.



9. Metal Grinding and Finishing

- Catch metal filings in an enclosed unit or on a tarpaulin.
- Sweep filing area to prevent washing metals into floor drains.

10. Storing and Disposing of Waste

- Store recyclable and non-recyclable waste separately.
- Place liquid waste (hazardous or otherwise) within a bermed or secondary containment area.
- Cover outdoor storage areas to prevent contact with rain water.
- Collect used parts for delivery to a scrap metal dealer.

11. Selecting and Controlling Inventory

- Purchase recyclable or non-toxic materials.
- Select "closed-loop" suppliers and purchase supplies in bulk.

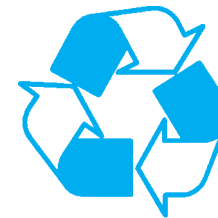

12. Outdoor Parking and Auto Maintenance

- Treat outdoor areas as an extension of your service bays or avoid using altogether.
- Sweep-up trash and dirt from outdoor parking and maintenance areas. Do not hose down areas. All non-storm water discharges are prohibited.
- Drain work areas to a sanitary drain rather than a storm drain. Contact the local sewer authority to determine if pretreatment is required.

13. Washing Vehicles, Cleaning Engines, and Other Steam Cleaning

- For occasional car exterior cleaning, minimize the water used and divert runoff to landscaped areas, keeping it out of the storm drain.
- Wash vehicles with biodegradable, phosphate-free detergent.
- Make sure no wastewater from engine or parts cleaning or steam cleaning is discharged where it may flow to a street, gutter, or storm drain.

14. Cleaning Work Areas

- Sweep or vacuum the shop floor frequently.
- Damp mop work areas - do not hose down work areas into the street or gutter.
- Do not pour mop water into the parking lot, street, gutter or storm drain.
- Use non-toxic cleaning products whenever possible.

Please remember:





Riverside County Stormwater Members

Flood Control District
(Lead Agency)
(951) 955-1250

County of Riverside
(951) 955-1000

City of Banning
(951) 922-3130

City of Beaumont
(951) 769-8520

City of Calimesa
(909) 795-9801

City of Canyon Lake
(951) 244-2955

Cathedral City
(760) 770-0349

City of Coachella
(760) 398-3502

City of Corona
(951) 736-2248

City of Desert Hot Springs
(760) 329-6411

City of Hemet
(951) 765-2300

City of Indian Wells
(760) 346-2489

City of San Jacinto
(951) 487-7330

City of Indio
(760) 391-4000

City of Lake Elsinore
(951) 674-3124

City of La Quinta
(760) 777-7000

City of Menifee
(951) 672-6777

City of Moreno Valley
(951) 413-3120

City of Murrieta
(951) 304-2489

City of Norco
(951) 735-3900

City of Palm Desert
(760) 346-0611

City of Palm Springs
(760) 323-8253

City of Perris
(951) 943-6100

City of Rancho Mirage
(760) 324-4511

City of Riverside
(951) 926-5311

City of Temecula
(951) 694-6444

City of Wildomar
(951) 677-7751

Coachella Valley Water District
(760) 398-2651

Stormwater Pollution

What you should know for...

Industrial & Commercial Facilities

Best Management Practices (BMPS) for:

- Industrial
- Commercial Facilities



The Riverside County "Only Rain Down the Storm Drain" Pollution Prevention Program gratefully acknowledges San Bernardino County's Stormwater Program for their contribution to this brochure.

3.2 INFILTRATION TRENCH

Type of BMP	LID - Infiltration
Treatment Mechanisms	Infiltration, Evapotranspiration (when vegetated), Evaporation
Maximum Drainage Area	10-acres
Other Names	None

Description

Infiltration trenches are shallow excavated areas that are filled with rock material to create a subsurface reservoir layer. The trench is sized to store the design capture volume, V_{BMP} , in the void space between the rocks. Over a period of 72 hours, the stormwater infiltrates through the bottom of the trench into the surrounding soil. Infiltration basins are highly effective in removing all targeted pollutants from stormwater runoff.

Figure 1 shows the components of an infiltration trench. The section shows the reservoir layer and observation well, which is used to monitor water depth. An overflow pipe that is used to bypass flows once the trench fills with stormwater is also shown.

Site Considerations

Location

The use of infiltration trenches may be restricted by concerns over groundwater contamination, soil permeability, and clogging at the site. See the applicable WQMP for any specific feasibility considerations for using infiltration BMPs. Where this BMP is being used, the soil beneath the basin must be thoroughly evaluated in a geotechnical report since the underlying soils are critical to the basin's long term performance. These basins may not be appropriate for the following site conditions:

- Industrial sites or locations where spills of toxic materials may occur.
- Sites with very low soil infiltration rates.
- Sites with high groundwater tables or excessively high soil infiltration rates, where pollutants can affect groundwater quality.
- Sites with unstabilized soil or construction activity upstream.
- On steeply sloping terrain.
- Infiltration trenches located in a fill condition should refer to Appendix A of this Handbook for details on special requirements/restrictions.

This BMP has a flat surface area, so it may be challenging to incorporate into steeply sloping terrain.

INFILTRATION TRENCH BMP FACT SHEET

Setbacks

Always consult your geotechnical engineer for site specific recommendations regarding setbacks for infiltration trenches. Recommended setbacks are needed to protect buildings, walls, onsite or nearby wells, streams, and tanks. Setbacks should be considered early in the design process as they affect where infiltration facilities may be placed and how deep they are allowed to be. For instance, depth setbacks can dictate fairly shallow facilities that will have a larger footprint and, in some cases, may make an infiltration trench infeasible. In that instance, another BMP must be selected.

In addition to setbacks recommended by the geotechnical engineer, infiltration trenches must be set back:

- 10 feet from the historic high groundwater mark (measured vertically from the bottom of the trench, as shown in Figure 1)
- 5 feet from bedrock or impermeable surface layer (measured vertically from the bottom of the trench, as shown in Figure 1)
- From all mature tree drip lines as indicated in Figure 1
- 100 feet horizontally from wells, tanks or springs

Setbacks to walls and foundations must be included as part of the Geotechnical Report.

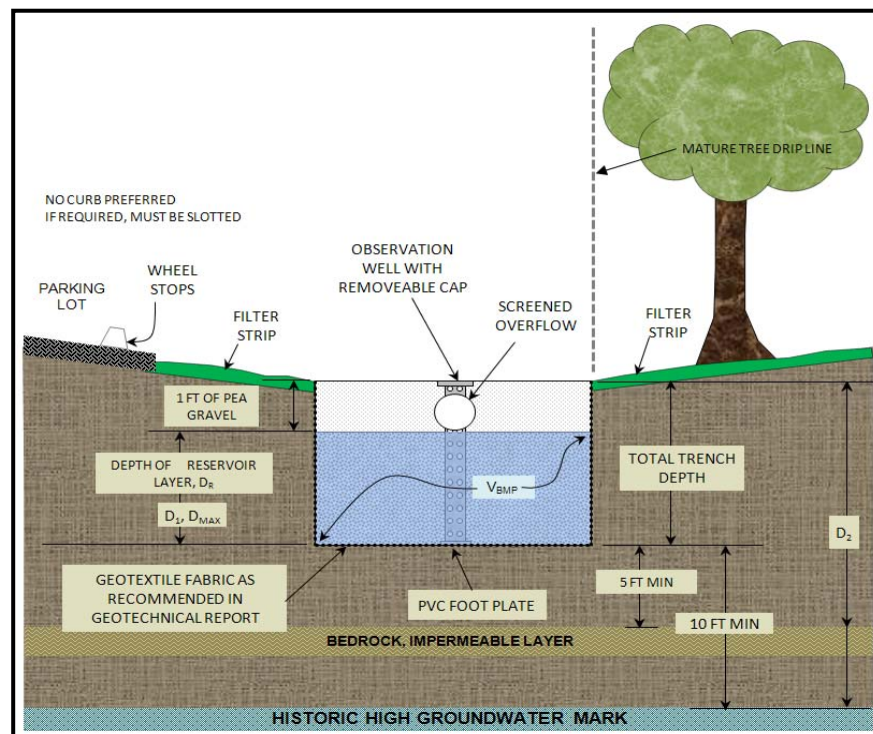

Figure 1 Section View of an Infiltration Trench

INFILTRATION TRENCH BMP FACT SHEET

Sediment Control

Infiltration BMPs have the risk of becoming plugged over time. To prevent this, sediment must be removed before stormwater enters the trench. Both sheet and concentrated flow types have requirements that should be considered in the design of an infiltration trench.

When sheet type flows approach the trench along its length (as illustrated in Figure 2), a vegetated filter strip should be placed between the trench

and the upstream drainage area. The filter strip must be a minimum of 5 feet wide and planted with grasses (preferably native) or covered with mulch.

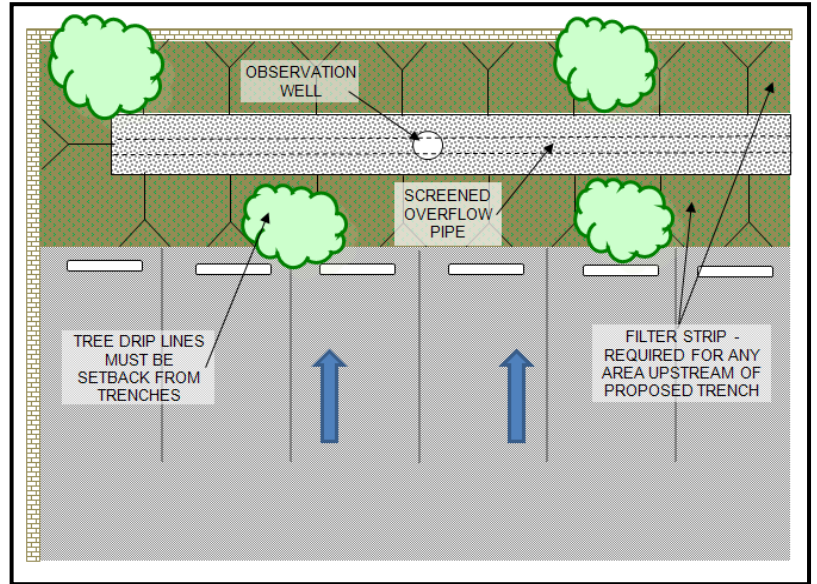

Figure 2 Plan View, Sheet Type Flows

Concentrated flows require a different approach. A 2004 Caltrans BMP Retrofit Report found that flow spreaders recommended in many water quality manuals are ineffective in distributing concentrated flows. As such, concentrated flows should either be directed toward a traditional vegetated swale (as shown on the right side of Figure 3) or to catch basin filters that can remove litter and sediment. Catch basins must discharge runoff as surface flow above the trench; they cannot outlet directly into the reservoir layer of the infiltration trench. If catch basins are used, the short and long term costs of the catch basin filters should be considered.

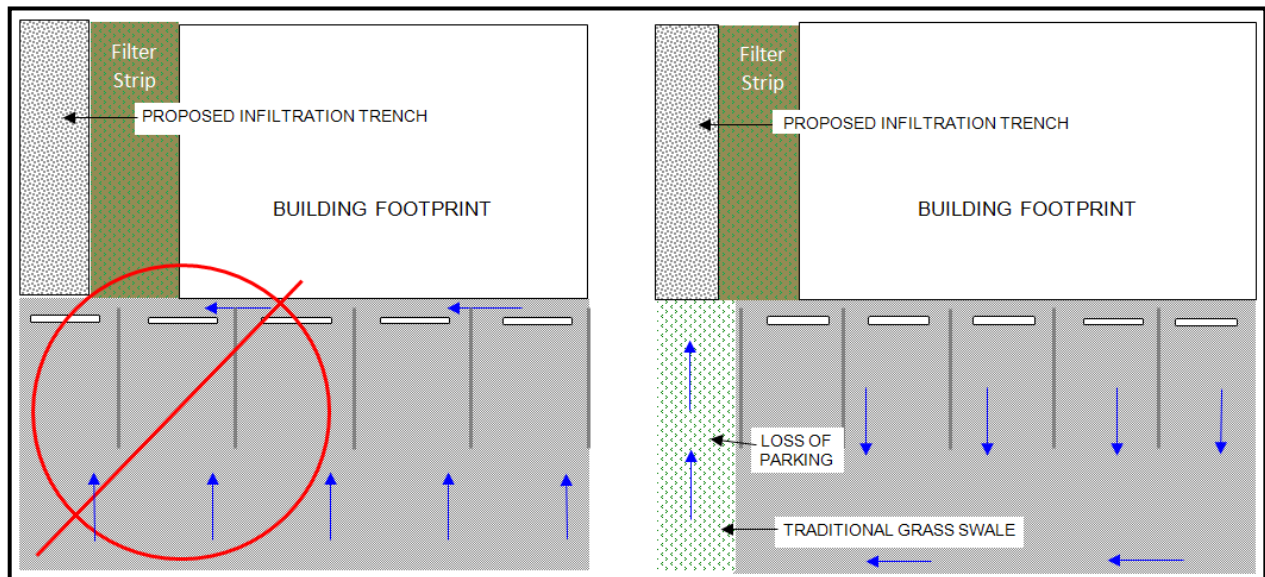

Figure 3 Plan View, Concentrated Flows

INFILTRATION TRENCH BMP FACT SHEET

Additional Considerations

Class V Status

In certain circumstances, for example, if an infiltration trench is “deeper than its widest surface dimension,” or includes an assemblage of perforated pipes, drain tiles, or other similar mechanisms intended to distribute fluids below the surface of the ground, it would probably be considered by the EPA to be a Class V injection well. Class V injection wells are subject to regulations and reporting requirements via the Underground Injection Control (UIC) Program. To ensure that infiltration trenches are not considered Class V wells, the design procedure in this manual requires that the trench not be deeper than it is wide.

Geotechnical Report

A geotechnical report must be included for all infiltration trenches. Appendix A of this Handbook entitled “Infiltration Testing Guidelines”, details which types of infiltration tests are acceptable and how many tests or boring logs must be performed. A Geotechnical Report must be submitted in support of all infiltration trenches. Setbacks to walls and foundations must be included in the Geotechnical Report.

Observation Wells

One or more observation wells should be provided. The observation well consists of a vertical section of perforated pipe, 4 to 6 inches in diameter, installed flush with top of trench on a foot plate and have a locking, removable cap.

Overflow

An overflow route is needed to bypass storm flows larger than the V_{BMP} or in the event of clogging. Overflow systems must connect to an acceptable discharge point such as a downstream conveyance system.

Maintenance Access

Normal maintenance of an infiltration trench includes maintenance of the filter strip as well as debris and trash removal from the surface of the trench and filter strip. More substantial maintenance requiring vehicle access may be required every 5 to 10 years. Vehicular access along the length of the swale should be provided to all infiltration trenches. It is preferred that trenches be placed longitudinally along a street or adjacent to a parking lot area. These conditions have high visibility which makes it more likely that the trench will be maintained on a regular basis.

INFILTRATION TRENCH BMP FACT SHEET

Inspection and Maintenance

Schedule	Inspection and Maintenance Activity
Every two weeks, or as often as necessary to maintain a pleasant appearance	<ul style="list-style-type: none"> - Maintain adjacent landscaped areas. Remove clippings from landscape maintenance activities. - Remove trash & debris
3 days after Major Storm Events	<ul style="list-style-type: none"> - Check for surface ponding. If ponding is only above the trench, remove, wash and replace pea gravel. May be needed every 5-10 years. - Check observation well for ponding. If the trench becomes plugged, remove rock materials. Provide a fresh infiltration surface by excavating an additional 2-4 inches of soil. Replace the rock materials.

Design and Sizing Criteria

Design Parameter	Design Criteria
Design Volume	V_{BMP}
Design Drawdown time	72 hrs
Maximum Tributary Drainage Area	10 acres
Maximum Trench Depth	8.0 ft
Width to Depth Ratio	Width must be greater than depth
Reservoir Rock Material	AASHTO #3 or 57 material or a clean, washed aggregate 1 to 3-in diameter equivalent
Filter Strip Width	Minimum of 5 feet in the direction of flow for all areas draining to trench
Filter Strip Slope	Max slope = 1%
Filter Strip Materials	Mulch or grasses (non-mowed variety preferred)
Historic High Groundwater Mark	10 ft or more below bottom of trench
Bedrock/Impermeable Layer Setback	5 ft or more below bottom of trench
Tree Setbacks	Mature tree drip line must not overhang the trench
Trench Lining Material	As recommended in Geotechnical Report

INFILTRATION TRENCH BMP FACT SHEET

Infiltration Trench Design Procedure

1. Enter the area tributary to the trench, maximum drainage area is 10 acres.
2. Enter the Design Volume, V_{BMP} , determined from Section 2.1 of this Handbook.
3. Enter the site infiltration rate, found in the geotechnical report.
4. Enter the factor of safety from Table 1 of Appendix A, Infiltration Testing.
5. Determine the maximum reservoir layer depth, D_{MAX} . The value is obtained by taking the smaller of two depth equations but may never exceed 8 feet. The first depth, D_1 is related to the infiltration rate of the soil. The second depth, D_2 , is related to required setbacks to groundwater, bedrock/impermeable layer. These parameters are shown in Figure 1.

Calculate D_1 .

$$D_1 = \frac{I \left(\frac{\text{in}}{\text{hr}} \right) \times 72 \text{ (hrs)}}{12 \left(\frac{\text{in}}{\text{ft}} \right) \times n/100 \times FS}$$

Where:

- I = site infiltration rate (in/hr), found in the geotechnical report
- FS = factor of safety, refer to Appendix A - Infiltration Testing
- n = porosity of the trench material, 40%

Calculate D_2 . Enter the depth to the seasonal high groundwater and bedrock/impermeable layer measured from the finished grade. The spreadsheet checks the minimum setbacks shown in Figure 1 and selects the smallest value. The equations are listed below for those doing hand calculations.

Minimum Setbacks (includes 1 foot for pea gravel):

- = Depth to historic high groundwater mark - 11 feet
- = Depth to impermeable layer - 6 feet

D_2 is the smaller of the two values.

D_{MAX} is the smaller value of D_1 and D_2 , and must be less than or equal to 8 feet.

6. Enter the proposed reservoir layer depth, D_R . The value must be no greater than D_{MAX} .

INFILTRATION TRENCH BMP FACT SHEET

7. Find the required surface area of the trench, A_S . Once D_R is entered, the spreadsheet will calculate the corresponding depth of water and the minimum surface area of the trench.

$$\text{Design } d_W = D_R \times (n/100) \qquad A_S = \frac{V_{BMP}}{\text{Design } d_W}$$

Where:

A_S = minimum area required (ft^2)

V_{BMP} = BMP storage volume (ft^3)

Design d_W = Depth of water in reservoir layer (ft)

8. Enter the proposed design surface area; it must be greater than the minimum surface area.
9. Calculate the minimum trench width. This is to ensure that EPA's Class V Injection well status is not triggered. The total trench depth (shown in Figure 1) includes the upper foot where the overflow pipe is located. The minimum surface dimension is $D_R + 1$ foot.

Additional Items

The following items detailed in the preceding sections should also be addressed in the design.

- Sediment Control
- Geotechnical Report
- Observation well(s)
- Overflow

INFILTRATION TRENCH BMP FACT SHEET

Reference Material

California Stormwater Quality Association. California Stormwater BMP Handbook New Development and Redevelopment. 2003.

County of Los Angeles Department of Public Works. Stormwater BMP Best Management Practice Design and Maintenance Manual for Publicly Maintained Storm Drain Systems. Los Angeles, CA, 2009.

LandSaver Stormwater Management System. Tech Sheet - Porosity of Structural Backfill. 2006.

United States Environmental Protection Agency. Office of Water, Washington D.C. Storm Water Technology Fact Sheet Vegetated Swales. 1999.

United States Environmental Protection Agency. Office of Water. Memorandum on Clarification on Which Stormwater Infiltration Practices/technologies Have the Potential to Be Regulated as "Class V" Wells by Underground Injection Control Program. By Linda Boornazian and Steve Heare. Washington D.C., 2008.

Ventura Countywide Stormwater Quality Management Program. Land Development Guidelines Biofilter Fact Sheet. Ventura, CA, 2001.

Ventura Countywide Stormwater Quality Management Program. Technical Guidance Manual for Stormwater Quality Control Measures. Ventura, CA, 2002.

STORMTECH SC-740 CHAMBER

Designed to meet the most stringent industry performance standards for superior structural integrity while providing designers with a cost-effective method to save valuable land and protect water resources. The StormTech system is designed primarily to be used under parking lots, thus maximizing land usage for private (commercial) and public applications. StormTech chambers can also be used in conjunction with Green Infrastructure, thus enhancing the performance and extending the service life of these practices.

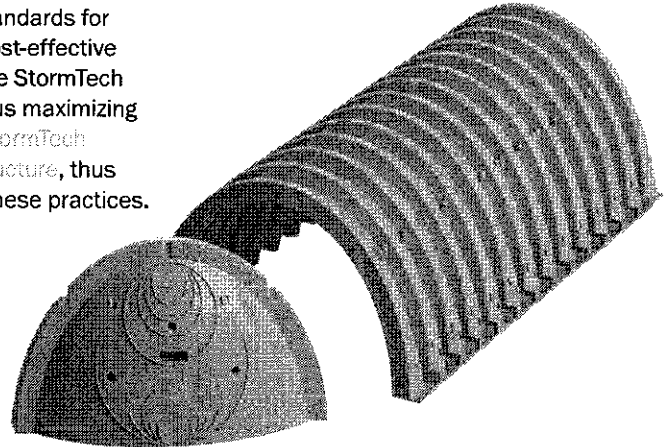

STORMTECH SC-740 CHAMBER (not to scale)

Nominal Chamber Specifications

Size (L x W x H)
85.4" x 51" x 30"
2,170 mm x 1,295 mm x 762 mm

Chamber Storage
45.9 ft³ (1.30 m³)

Min. Installed Storage*
74.9 ft³ (2.12 m³)

Weight
74.0 lbs (33.6 kg)

Shipping
30 chambers/pallet
60 end caps/pallet
12 pallets/truck

*Assumes 6" (150 mm) stone above, below and between chambers and 40% stone porosity.

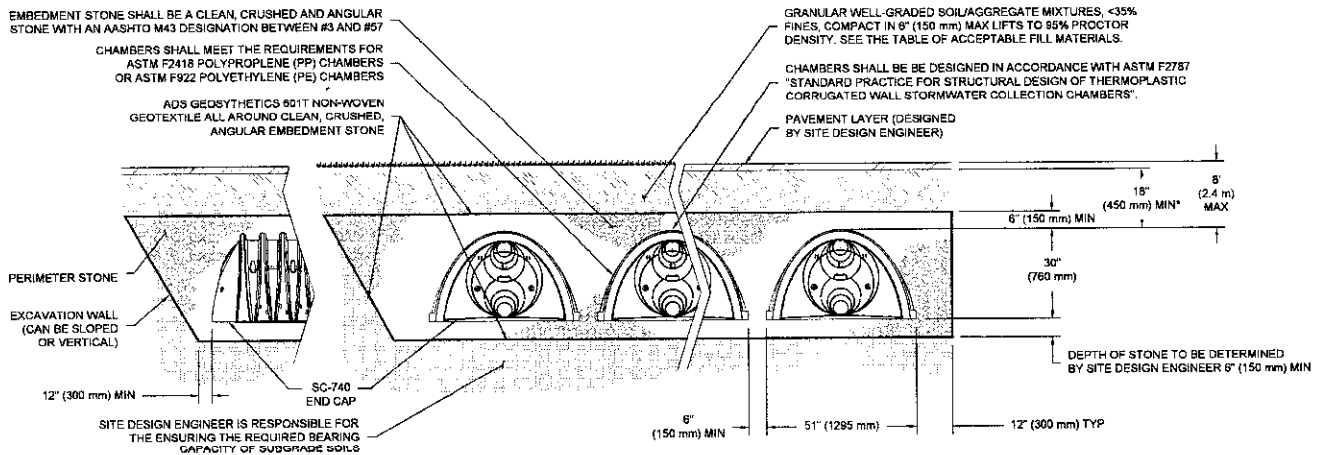
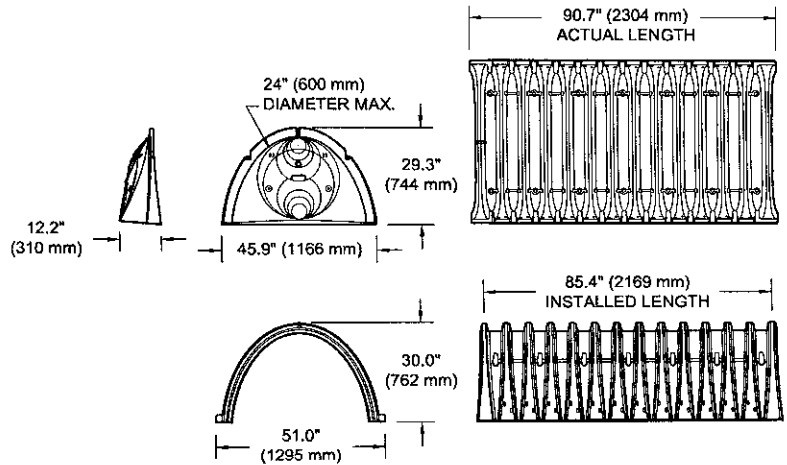

*MINIMUM COVER TO BOTTOM OF FLEXIBLE PAVEMENT. FOR UNPAVED INSTALLATIONS WHERE RUTTING FROM VEHICLES MAY OCCUR, INCREASE COVER TO 24" (600 mm).

SC-740 CUMULATIVE STORAGE VOLUMES PER CHAMBER

Assumes 40% Stone Porosity. Calculations are Based Upon a 6" (150 mm) Stone Base Under Chambers.

Depth of Stone Above Chamber (inches)	Direction of Stone	Storage Volume (ft ³)	Total Storage Volume (ft ³)	
42 (1067)	↑	45.90 (1.300)	74.90 (2.121)	
41 (1041)		45.90 (1.300)	73.77 (2.089)	
40 (1016)		45.90 (1.300)	72.64 (2.057)	
39 (991)		↓	45.90 (1.300)	71.52 (2.025)
38 (965)			45.90 (1.300)	70.39 (1.993)
37 (940)			45.90 (1.300)	69.26 (1.961)
36 (914)			45.90 (1.300)	68.14 (1.929)
35 (889)			45.85 (1.298)	66.98 (1.897)
34 (864)			45.69 (1.294)	65.75 (1.862)
33 (838)			45.41 (1.286)	64.46 (1.825)
32 (813)	44.81 (1.269)		62.97 (1.783)	
31 (787)	44.01 (1.246)		61.36 (1.737)	
30 (762)	43.06 (1.219)		59.66 (1.689)	
29 (737)	41.98 (1.189)	57.89 (1.639)		
28 (711)	40.80 (1.155)	56.05 (1.587)		
27 (686)	39.54 (1.120)	54.17 (1.534)		
26 (660)	38.18 (1.081)	52.23 (1.479)		
25 (635)	36.74 (1.040)	50.23 (1.422)		
24 (610)	35.22 (0.977)	48.19 (1.365)		
23 (584)	33.64 (0.953)	46.11 (1.306)		
22 (559)	31.99 (0.906)	44.00 (1.246)		
21 (533)	30.29 (0.858)	41.85 (1.185)		
20 (508)	28.54 (0.808)	39.67 (1.123)		
19 (483)	26.74 (0.757)	37.47 (1.061)		
18 (457)	24.89 (0.705)	35.23 (0.997)		
17 (432)	23.00 (0.651)	32.96 (0.939)		
16 (406)	21.06 (0.596)	30.68 (0.869)		
15 (381)	19.09 (0.541)	28.36 (0.803)		
14 (356)	17.08 (0.484)	26.03 (0.737)		
13 (330)	15.04 (0.426)	23.68 (0.670)		
12 (305)	12.97 (0.367)	21.31 (0.608)		
11 (279)	10.87 (0.309)	18.92 (0.535)		
10 (254)	8.74 (0.247)	16.51 (0.468)		
9 (229)	6.58 (0.186)	14.09 (0.399)		
8 (203)	4.41 (0.125)	11.66 (0.330)		
7 (178)	2.21 (0.063)	9.21 (0.264)		
6 (152)	↑	0 (0)	6.76 (0.191)	
5 (127)		0 (0)	5.63 (0.160)	
4 (102)		↓	0 (0)	4.51 (0.128)
3 (76)			0 (0)	3.38 (0.096)
2 (51)			0 (0)	2.25 (0.064)
1 (25)			0 (0)	1.13 (0.032)

Note: Add 1.13 ft³ (0.032 m³) of storage for each additional inch (25 mm) of stone foundation.

STORAGE VOLUME PER CHAMBER FT³ (M³)

Stone Chamber Above Chamber (inches)	Stone Chamber Below Chamber (inches)	Stone Foundation Depth (inches)		
		6" (150)	12" (300)	18" (450)
SC-740 Chamber		45.9 (1.3)	74.9 (2.1)	88.4 (2.5)

Note: Assumes 6" (150 mm) stone above chambers, 6" (150 mm) row spacing and 40% stone porosity.

AMOUNT OF STONE PER CHAMBER

English Tons (tons)	Stone Foundation Depth		
	6"	12"	18"
SC-740	3.8 (2.8)	4.6 (3.3)	5.5 (3.9)
Metric Tons (metric tons)	3.450 (2.1)	4.170 (2.5)	4.490 (3.0)

Note: Assumes 6" (150 mm) of stone above and between chambers.

VOLUME EXCAVATION PER CHAMBER YD³ (M³)

SC-740	Stone Foundation Depth		
	6" (150)	12" (300)	18" (450)
SC-740	5.5 (4.2)	6.2 (4.7)	6.8 (5.2)

Note: Assumes 6" (150 mm) of row separation and 18" (450 mm) of cover. The volume of excavation will vary as depth of cover increases.



Working on a project?
Visit us at www.stormtech.com
and utilize the StormTech Design Tool

For more information on the StormTech SC-740 Chamber and other ADS products, please contact our Customer Service Representatives at 1-800-821-6710

THE MOST ADVANCED NAME IN WATER MANAGEMENT SOLUTIONS™

Advanced Drainage Systems, Inc.
4640 Trueman Blvd., Hilliard, OH 43026
1-800-821-6710 www.ads-pipe.com

ADS "Terms and Conditions of Sale" are available on the ADS website, www.ads-pipe.com
The ADS logo and the Green Stripe are registered trademarks of Advanced Drainage Systems, Inc.
StormTech™ is a registered trademark of StormTech, Inc.
© 2017 Advanced Drainage Systems, Inc. # S16 090508 09/17 CS

ACCEPTABLE FILL MATERIALS: STORMTECH SC-740 CHAMBER SYSTEMS

MATERIAL LOCATION	DESCRIPTION	AASHTO MATERIAL CLASSIFICATIONS	COMPACTION / DENSITY REQUIREMENT
D	FINAL FILL: FILL MATERIAL FOR LAYER 'D' STARTS FROM THE TOP OF THE 'C' LAYER TO THE BOTTOM OF FLEXIBLE PAVEMENT OR UNPAVED FINISHED GRADE ABOVE. NOTE THAT PAVEMENT SUBBASE MAY BE PART OF THE 'D' LAYER.	N/A	PREPARE PER SITE DESIGN ENGINEER'S PLANS. PAVED INSTALLATIONS MAY HAVE STRINGENT MATERIAL AND PREPARATION REQUIREMENTS.
C	INITIAL FILL: FILL MATERIAL FOR LAYER 'C' STARTS FROM THE TOP OF THE EMBEDMENT STONE ('B' LAYER) TO 18" (450 mm) ABOVE THE TOP OF THE CHAMBER. NOTE THAT PAVEMENT SUBBASE MAY BE A PART OF THE 'C' LAYER.	AASHTO M145 A-1, A2-4, A-3 OR AASHTO M43 3, 357, 4, 467, 5, 56, 57, 6, 67, 68, 7, 78, 8, 89, 9, 10	BEGIN COMPACTIONS AFTER 12" (300 mm) OF MATERIAL OVER THE CHAMBERS IS REACHED. COMPACT ADDITIONAL LAYERS IN 6" (150 mm) MAX LIFTS TO A MIN. 95% PROCTOR DENSITY FOR WELL GRADED MATERIAL AND 95% RELATIVE DENSITY FOR PROCESSED AGGREGATE MATERIALS. ROLLER GROSS VEHICLE WEIGHT NOT TO EXCEED 22,000 lbs (99 kN). DYNAMIC FORCE NOT TO EXCEED 22,000 lbs (99 kN).
B	EMBEDMENT STONE: FILL SURROUNDING THE CHAMBERS FROM THE FOUNDATION STONE ('A' LAYER) TO THE 'C' LAYER ABOVE.	AASHTO M43 3, 357, 4, 467, 5, 56, 57	NO COMPACTION REQUIRED.
A	FOUNDATION STONE: FILL BELOW CHAMBERS FROM THE SURGRADE UP TO THE FOOT (BOTTOM) OF THE CHAMBER.	AASHTO M43 3, 357, 4, 467, 5, 56, 57	PLATE COMPACT OR ROLL TO ACHIEVE A FLAT SURFACE. ^{2,3}

PLEASE NOTE:

- THE LISTED AASHTO DESIGNATIONS ARE FOR GRADATIONS ONLY. THE STONE MUST ALSO BE CLEAN, CRUSHED, ANGULAR. FOR EXAMPLE, A SPECIFICATION FOR #4 STONE WOULD STATE: "CLEAN, CRUSHED, ANGULAR NO. 4 (AASHTO M43) STONE".
- STORMTECH COMPACTION REQUIREMENTS ARE MET FOR 'A' LOCATION MATERIALS WHEN PLACED AND COMPACTED IN 6" (150 mm) (MAX) LIFTS USING TWO FULL COVERAGES WITH A VIBRATORY COMPACTOR FOR SPECIAL LOAD DESIGNS, CONTACT STORMTECH FOR COMPACTION REQUIREMENTS.
- WHERE INFILTRATION SURFACES MAY BE COMPROMISED BY COMPACTION, FOR STANDARD DESIGN LOAD CONDITIONS, A FLAT SURFACE MAY BE ACHIEVED BY RAKING OR DRAGGING WITHOUT COMPACTION EQUIPMENT. FOR SPECIAL LOAD DESIGNS, CONTACT STORMTECH FOR COMPACTION REQUIREMENTS.
- ONCE LAYER 'C' IS PLACED, ANY SOIL/MATERIAL CAN BE PLACED IN LAYER 'D' UP TO THE FINISHED GRADE. MOST PAVEMENT SUBBASE SOILS CAN BE USED TO REPLACE THE MATERIAL REQUIREMENTS OF LAYER 'C' OR 'D' AT THE SITE DESIGN ENGINEER'S DISCRETION.

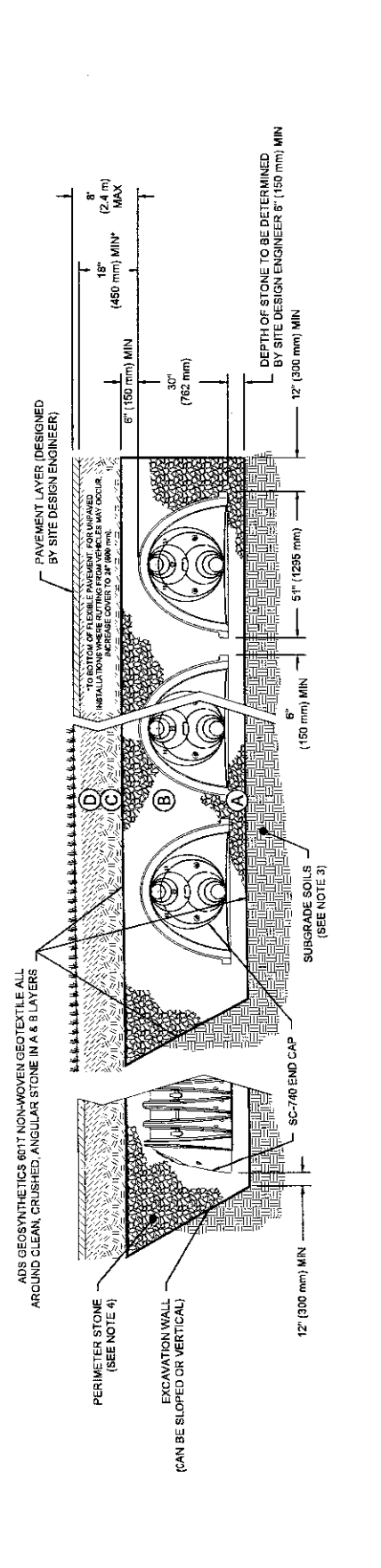

- NOTES:**
- CHAMBERS SHALL MEET THE REQUIREMENTS OF ASTM F2418-16a, "STANDARD SPECIFICATION FOR POLYPROPYLENE (PP) CORRUGATED WALL STORMWATER COLLECTION CHAMBERS".
 - SC-740 CHAMBERS SHALL BE DESIGNED IN ACCORDANCE WITH ASTM F2787 "STANDARD PRACTICE FOR STRUCTURAL DESIGN OF THERMOPLASTIC CORRUGATED WALL STORMWATER COLLECTION CHAMBERS".
 - THE SITE DESIGN ENGINEER IS RESPONSIBLE FOR ASSESSING THE BEARING RESISTANCE (ALLOWABLE BEARING CAPACITY) OF THE SUBGRADE SOILS AND THE DEPTH OF FOUNDATION STONE WITH CONSIDERATION FOR THE RANGE OF EXPECTED SOIL MOISTURE CONDITIONS.
 - PERIMETER STONE MUST BE EXTENDED HORIZONTALLY TO THE EXCAVATION WALL FOR BOTH VERTICAL AND SLOPED EXCAVATION WALLS.
 - REQUIREMENTS FOR HANDLING AND INSTALLATION:
 - TO MAINTAIN THE WIDTH OF CHAMBERS DURING SHIPPING AND HANDLING, CHAMBERS SHALL HAVE INTEGRAL INTERLOCKING STACKING LUGS.
 - TO ENSURE A SECURE JOINT DURING INSTALLATION AND BACKFILL, THE HEIGHT OF THE CHAMBER JOINT SHALL NOT BE LESS THAN 2".
 - TO ENSURE THE INTEGRITY OF THE ARCH SHAPE DURING INSTALLATION:
 - THE ARCH STIFFNESS CONSTANT AS DEFINED IN SECTION 6.2.8 OF ASTM F2418 SHALL BE GREATER THAN OR EQUAL TO 950 LB-IN/IN. AND b) TO RESIST CHAMBER DEFORMATION DURING INSTALLATION AT ELEVATED TEMPERATURES (ABOVE 73° F / 23° C), CHAMBERS SHALL BE PRODUCED FROM REFLECTIVE GOLD OR YELLOW COLORS.

DATE: 05-10-19
DRAWN: KR
CHECKED: KR

PROJECT #: SC-740
STANDARD CROSS SECTION

DATE: _____
BY: _____
CHECKED: _____

DESCRIPTION: _____
DATE: _____
BY: _____
CHECKED: _____

660-425-8188 | 888-627-2881 | WWW.STORMTECH.COM
Stormtech
 Stormwater Management Systems
 701 WOODBINE ROAD, SUITE 1 | BOONVILLE, OH 43017

4640 TRUMAN BLVD
HILLIARD, OH 43026
ADVANCED PAVEMENT SYSTEMS, INC.

1 OF 1
SHEET

SC-740 TECHNICAL SPECIFICATION

NTS

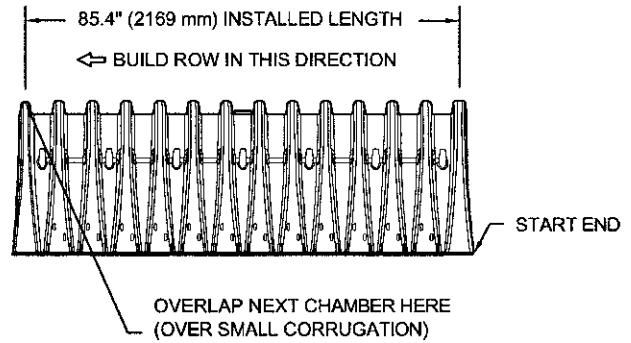
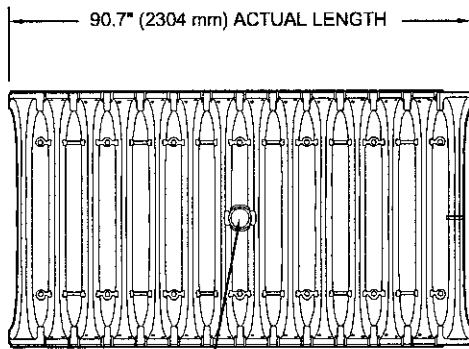

ACCEPTS 4" (100 mm) SCH 40 PVC PIPE FOR INSPECTION PORT. FOR PIPE SIZES LARGER THAN 4" (100 mm) UP TO 10" (250 mm) USE INSERTA TEE CONNECTION CENTERED ON A CHAMBER CREST CORRUGATION

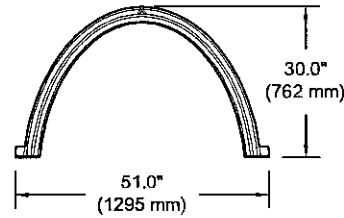
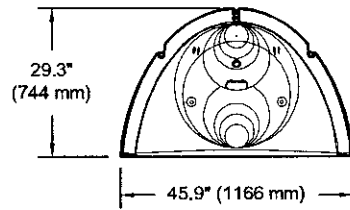
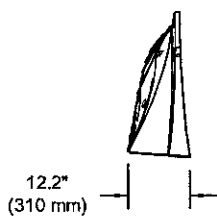

NOMINAL CHAMBER SPECIFICATIONS

SIZE (W X H X INSTALLED LENGTH)	51.0" X 30.0" X 85.4"	(1295 mm X 762 mm X 2169 mm)
CHAMBER STORAGE	45.9 CUBIC FEET	(1.30 m ³)
MINIMUM INSTALLED STORAGE*	74.9 CUBIC FEET	(2.12 m ³)
WEIGHT	75.0 lbs.	(33.6 kg)

*ASSUMES 6" (152 mm) STONE ABOVE, BELOW, AND BETWEEN CHAMBERS

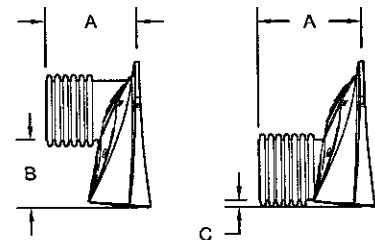

STUBS AT BOTTOM OF END CAP FOR PART NUMBERS ENDING WITH "B"
STUBS AT TOP OF END CAP FOR PART NUMBERS ENDING WITH "T"

PART #	STUB	A	B	C
SC740EPE06T / SC740EPE06TPC	6" (150 mm)	10.9" (277 mm)	18.5" (470 mm)	---
SC740EPE06B / SC740EPE06BPC	6" (150 mm)	10.9" (277 mm)	---	0.5" (13 mm)
SC740EPE08T / SC740EPE08TPC	8" (200 mm)	12.2" (310 mm)	16.5" (419 mm)	---
SC740EPE08B / SC740EPE08BPC	8" (200 mm)	12.2" (310 mm)	---	0.6" (15 mm)
SC740EPE10T / SC740EPE10TPC	10" (250 mm)	13.4" (340 mm)	14.5" (368 mm)	---
SC740EPE10B / SC740EPE10BPC	10" (250 mm)	13.4" (340 mm)	---	0.7" (18 mm)
SC740EPE12T / SC740EPE12TPC	12" (300 mm)	14.7" (373 mm)	12.5" (318 mm)	---
SC740EPE12B / SC740EPE12BPC	12" (300 mm)	14.7" (373 mm)	---	1.2" (30 mm)
SC740EPE15T / SC740EPE15TPC	15" (375 mm)	18.4" (467 mm)	9.0" (229 mm)	---
SC740EPE15B / SC740EPE15BPC	15" (375 mm)	18.4" (467 mm)	---	1.3" (33 mm)
SC740EPE18T / SC740EPE18TPC	18" (450 mm)	19.7" (500 mm)	5.0" (127 mm)	---
SC740EPE18B / SC740EPE18BPC	18" (450 mm)	19.7" (500 mm)	---	1.6" (41 mm)
SC740EPE24B*	24" (600 mm)	18.5" (470 mm)	---	0.1" (3 mm)

ALL STUBS, EXCEPT FOR THE SC740EPE24B ARE PLACED AT BOTTOM OF END CAP SUCH THAT THE OUTSIDE DIAMETER OF THE STUB IS FLUSH WITH THE BOTTOM OF THE END CAP. FOR ADDITIONAL INFORMATION CONTACT STORMTECH AT 1-888-892-2694.

* FOR THE SC740EPE24B THE 24" (600 mm) STUB LIES BELOW THE BOTTOM OF THE END CAP APPROXIMATELY 1.75" (44 mm). BACKFILL MATERIAL SHOULD BE REMOVED FROM BELOW THE N-12 STUB SO THAT THE FITTING SITS LEVEL.

NOTE: ALL DIMENSIONS ARE NOMINAL

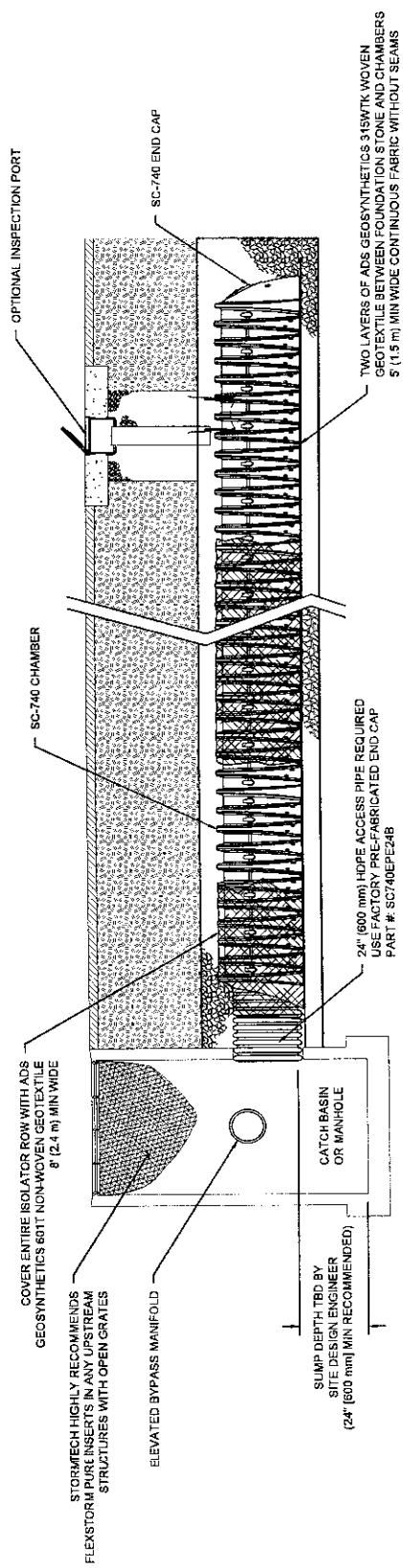

SC-740 ISOLATOR ROW DETAIL
 NTS

INSPECTION & MAINTENANCE

- STEP 1) INSPECT ISOLATOR ROW FOR SEDIMENT AND INSPECTION PORTS (IF PRESENT)
- A.1. REMOVE/OPEN LID ON NYLOPLAST INLINE DRAIN
 - A.2. REMOVE AND CLEAN FLEXSTORM FILTER IF INSTALLED
 - A.3. USING A FLASHLIGHT AND STADIA ROD, MEASURE DEPTH OF SEDIMENT AND RECORD ON MAINTENANCE LOG
 - A.4. LOWER A CAMERA INTO ISOLATOR ROW FOR VISUAL INSPECTION OF SEDIMENT LEVELS (OPTIONAL)
 - A.5. IF SEDIMENT IS AT, OR ABOVE, 3" (80 mm) PROCEED TO STEP 2. IF NOT, PROCEED TO STEP 3.
- B. ALL ISOLATOR ROWS
- B.1. REMOVE COVER FROM STRUCTURE AT UPSTREAM END OF ISOLATOR ROW
 - B.2. USING A FLASHLIGHT, INSPECT DOWN THE ISOLATOR ROW THROUGH OUTLET PIPE
 - i) MIRRORS ON POLES OR CAMERAS MAY BE USED TO AVOID A CONFINED SPACE ENTRY
 - ii) FOLLOW OSHA REGULATIONS FOR CONFINED SPACE ENTRY IF ENTERING MANHOLE
 - B.3. IF SEDIMENT IS AT, OR ABOVE, 3" (80 mm) PROCEED TO STEP 2. IF NOT, PROCEED TO STEP 3.
- STEP 2) CLEAN OUT ISOLATOR ROW USING THE JETVAC PROCESS
- A. AFKED CULTVERT CLEANING NOZZLE WITH REAR FACING SPREAD OF 45" (1.1 m) OR MORE IS PREFERRED
 - B. APPLY MULTIPLE PASSES OF JETVAC UNTIL BACKFLUSH WATER IS CLEAN
 - C. VACUUM STRUCTURE SUMP AS REQUIRED
- STEP 3) REPLACE ALL COVERS, GRATES, FILTERS, AND LIDS. RECORD OBSERVATIONS AND ACTIONS.
- STEP 4) INSPECT AND CLEAN BASINS AND MANHOLES UPSTREAM OF THE STORMTECH SYSTEM.

NOTES

1. INSPECT EVERY 6 MONTHS DURING THE FIRST YEAR OF OPERATION. ADJUST THE INSPECTION INTERVAL BASED ON PREVIOUS OBSERVATIONS OF SEDIMENT ACCUMULATION AND HIGH WATER ELEVATIONS.
2. CONDUCT JETTING AND VACTORING ANNUALLY OR WHEN INSPECTION SHOWS THAT MAINTENANCE IS NECESSARY.

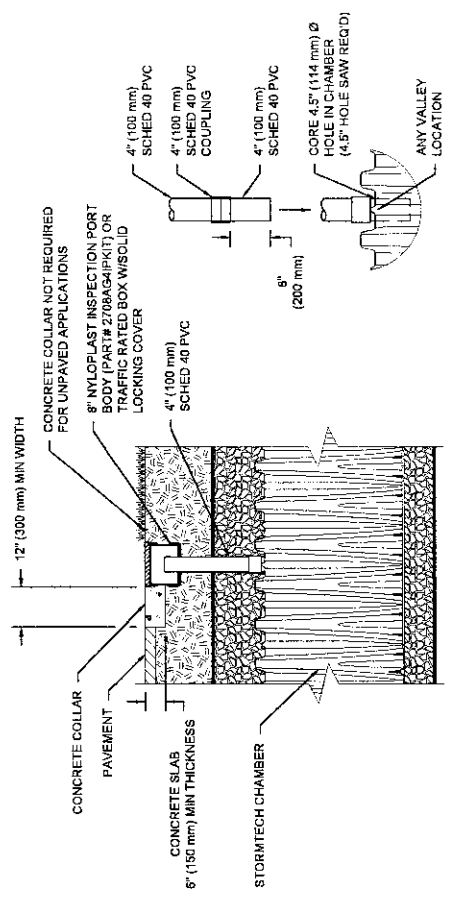

CONNECTION DETAIL
 NTS

4\"/>

- NOTES:
1. INSPECTION PORTS MAY BE CONNECTED THROUGH ANY CHAMBER CORRUGATION VALLEY.
 2. ALL SCHEDULE 40 FITTINGS TO BE SOLVENT CEMENTED (4\"/>

SiteASSIST™
by StormTech

FOR STORMTECH
INSTRUCTIONS,
DOWNLOAD THE
INSTALLATION APP



StormTech Construction Guide

StormTech®

An **MMWDs** company

SC-310/SC-740/DC-780

REQUIRED MATERIALS AND EQUIPMENT LIST

- Acceptable fill materials per Table 1
- Woven and non-woven geotextiles

- StormTech solid end caps and pre-cored end caps
- StormTech chambers
- StormTech manifolds and fittings

IMPORTANT NOTES:

- This installation guide provides the minimum requirements for proper installation of chambers. Non-adherence to this guide may result in damage to chambers during installation. Replacement of damaged chambers during or after backfilling is costly and very time consuming. It is recommended that all installers are familiar with this guide, and that the contractor inspects the chambers for distortion, damage and joint integrity as work progresses.
- Use of a dozer to push embedment stone between the rows of chambers may cause damage to chambers and is not an acceptable backfill method. Any chambers damaged by using the "dump and push" method are not covered under the StormTech standard warranty.
- Care should be taken in the handling of chambers and end caps. Avoid dropping, prying or excessive force on chambers during removal from pallet and initial placement.

Requirements for System Installation



Excavate bed and prepare subgrade per engineer's plans.

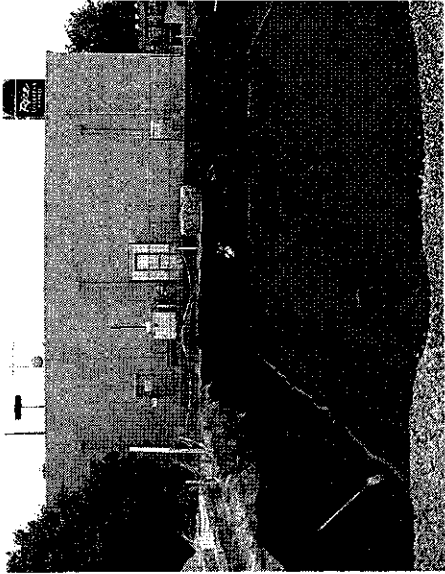

Place non-woven geotextile over prepared soils and up excavation walls. Install underdrains if required.

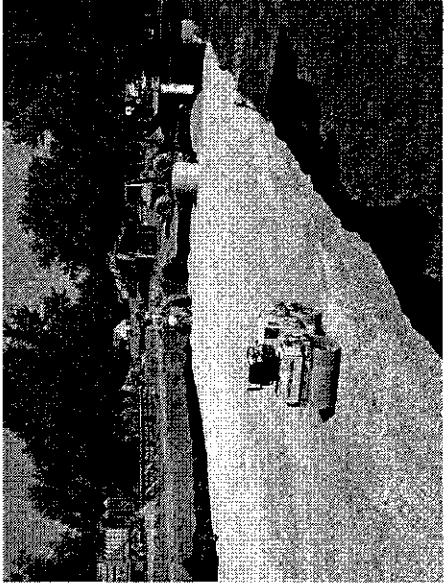

Place clean, crushed, angular stone foundation 6" (150 mm) min. Compact to achieve a flat surface.

Install Scour Fabric and Chamber Assembly



Install manifolds and lay out woven scour geotextile in inlet rows [min. 12.5 ft (3.8 m)] at each inlet end cap. Place a continuous piece (no seams, double layer) along entire length of Isolator® Row(s).

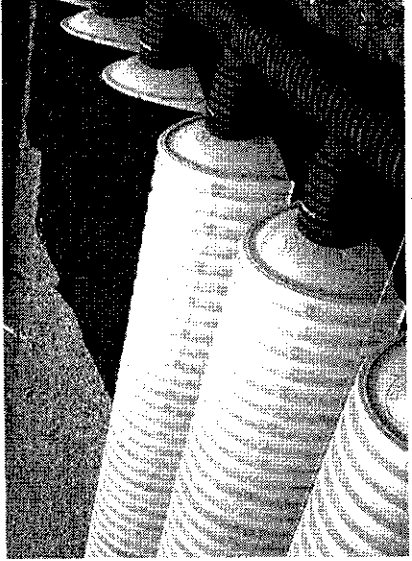

Align the first chamber and end cap of each row with inlet pipes. Contractor may choose to postpone stone placement around end chambers and leave ends of rows open for easy inspection of chambers during the backfill process.

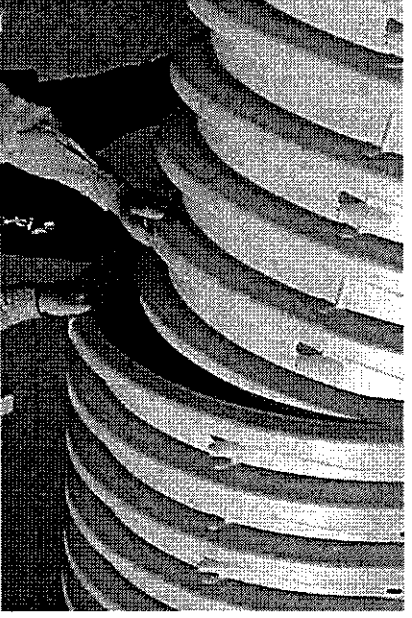

Continue installing chambers by overlapping chamber end corrugations. Chamber joints are labeled "Lower Joint – Overlap Here" and "Build this direction – Upper Joint". Be sure that the chamber placement does not exceed the reach of the construction equipment used to place the stone. Maintain minimum 6" (150 mm) spacing between rows.

Attach the End Caps



Lift the end of the chamber a few inches off the ground. With the curved face of the end cap facing outward, place the end cap into the chamber's end corrugation.

Prefabricated End Caps

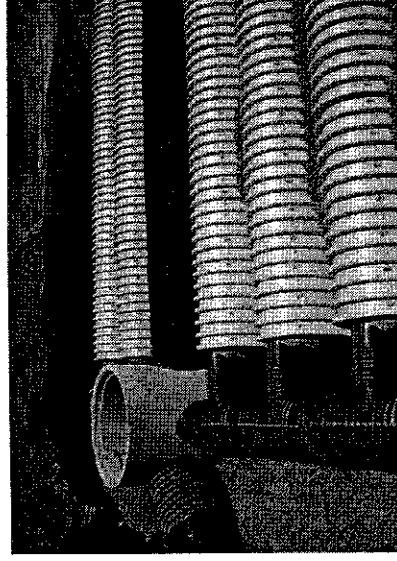

24" (600 mm) inlets are the maximum size that can fit into a SC-740/DC-780 end cap and must be prefabricated with a 24" (600 mm) pipe stub. SC-310 chambers with a 12" (300 mm) inlet pipe must use a prefabricated end cap with a 12" (300 mm) pipe stub.

Isolator Row



Place two continuous layers of ADS Woven fabric between the foundation stone and the isolator row chambers, making sure the fabric lays flat and extends the entire width of the chamber feet. Drape a strip of ADS non-woven geotextile over the row of chambers (not required over DC-780). This is the same type of non-woven geotextile used as a separation layer around the angular stone of the StormTech system.

Proper Backfilling of Chambers - Backfilled Stone

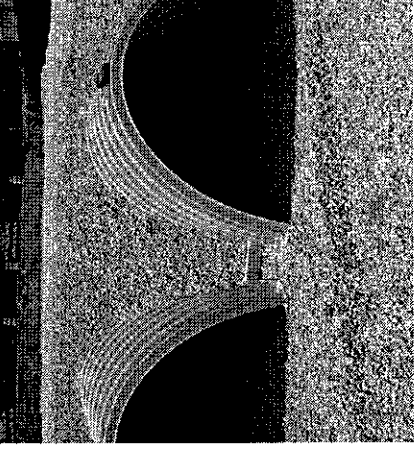
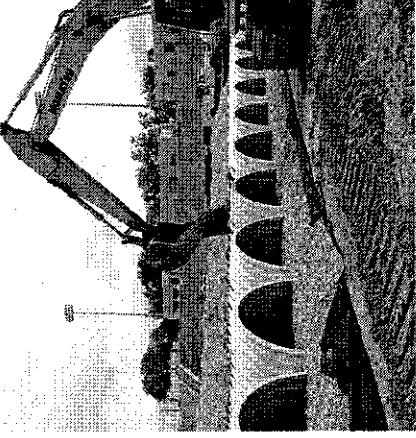
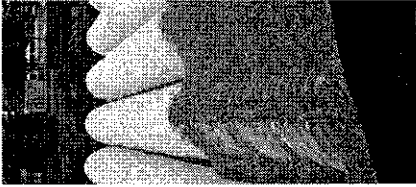
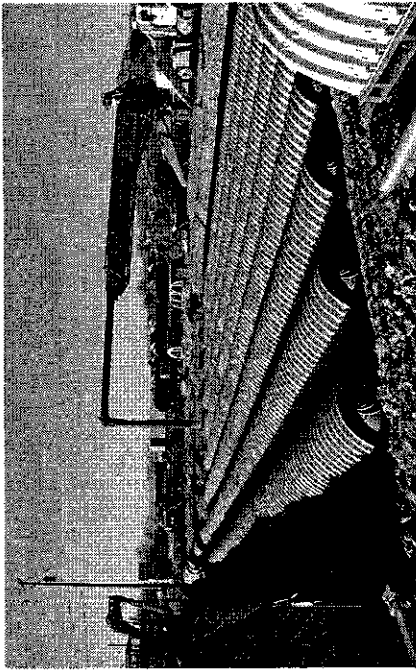

Initial embedment shall be spotted along the centerline of the chamber evenly anchoring the lower portion of the chamber. This is best accomplished with a stone conveyor or excavator reaching along the row.

No equipment shall be operated on the bed at this stage of the installation. Excavators must be located off the bed. Dump trucks shall not dump stone directly on to the bed. Dozers or loaders are not allowed on the bed at this time.

Proper Backfilling of Chambers - Unbackfilled Stone

PERMITS ARE REQUIRED FOR THE USE OF THIS PRODUCT. SEE THE PERMITTING SECTION OF THE TECHNICAL MANUAL FOR A COMPLETE LIST OF PERMITS AND REGULATIONS. SEE THE PERMITTING SECTION OF THE TECHNICAL MANUAL FOR A COMPLETE LIST OF PERMITS AND REGULATIONS. SEE THE PERMITTING SECTION OF THE TECHNICAL MANUAL FOR A COMPLETE LIST OF PERMITS AND REGULATIONS.

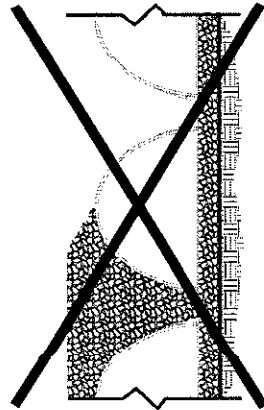

UNEVEN BACKFILL

Backfill chambers evenly. Stone column height should never differ by more than 12" (300 mm) between adjacent chamber rows or between chamber rows and perimeter.

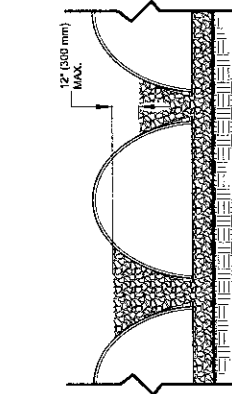

EVEN BACKFILL

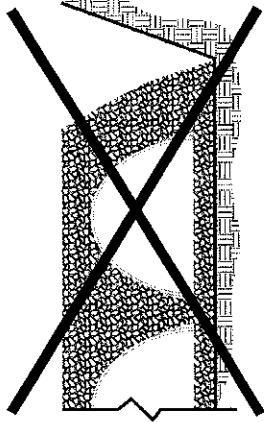

PERIMETER NOT BACKFILLED

Perimeter stone must be brought up evenly with chamber rows. Perimeter must be fully backfilled, with stone extended horizontally to the excavation wall.

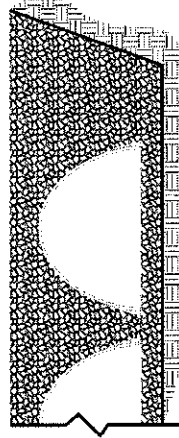

PERIMETER FULLY BACKFILLED

Backfill "Embedment Stone & Cover Stone

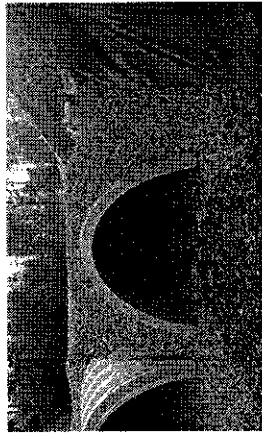

Continue evenly backfilling between rows and around perimeter until embedment stone reaches tops of chambers. Perimeter stone must extend horizontally to the excavation wall for both straight or sloped sidewalls. **Only after chambers have been backfilled to top of chamber and with a minimum 6" (150 mm) of cover stone on top of chambers can small dozers be used over the chambers for backfilling remaining cover stone.**

Small dozers and skid loaders may be used to finish grading stone backfill in accordance with ground pressure limits in Table 2. They must push material parallel to rows only. Never push perpendicular to rows. StormTech recommends that the contractor inspect chambers before placing final backfill. Any chambers damaged by construction shall be removed and replaced.

Final Backfill of Chambers - Final Material

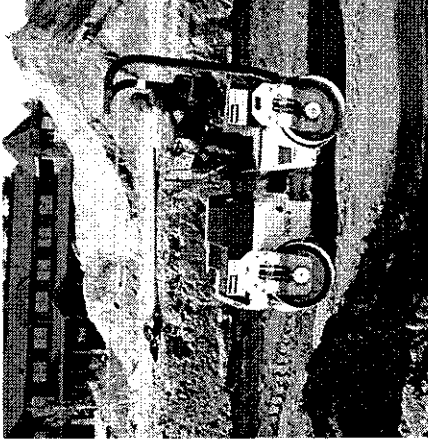

Install non-woven geotextile over stone. Geotextile must overlap 24" (600 mm) min. where edges meet. Compact each lift of backfill as specified in the site design engineer's drawings. Roller travel parallel with rows.

Inserta Tee Detail

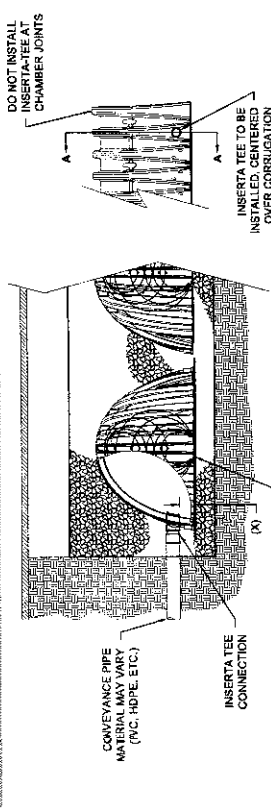

PLACE ADS GEOSYNTHETICS 315 WOVEN GEOTEXTILE (CENTERED ON INSERTA-TEE INLET) OVER BEDDING & ALL CONNECTIONS. GEOTEXTILE MUST EXTEND 8" (150 mm) PAST CHAMBER FOOT

SECTION A-A

SIDE VIEW

CHAMBER	MAX. DIAMETER OF INSERTA TEE	HEIGHT FROM BASE OF CHAMBER (A)
SC-310	6" (150 mm)	4" (100 mm)
SC-740	10" (250 mm)	4" (100 mm)
DC-780	10" (250 mm)	4" (100 mm)
AC-3500	12" (300 mm)	8" (200 mm)
MC-4500	12" (300 mm)	8" (200 mm)

INSERTA TEE FITTINGS AVAILABLE FOR STD. 3E, SCH. 40 IPS, GASIFIED & SOLVENT WELD, A-12, HP, STORM, C-800 OR DUCTILE IRON.

NOTE: PART NUMBERS WILL VARY BASED ON INLET PIPE MATERIALS. CONTACT STORMTECH FOR MORE INFORMATION.

StormTech Isolator Row Detail

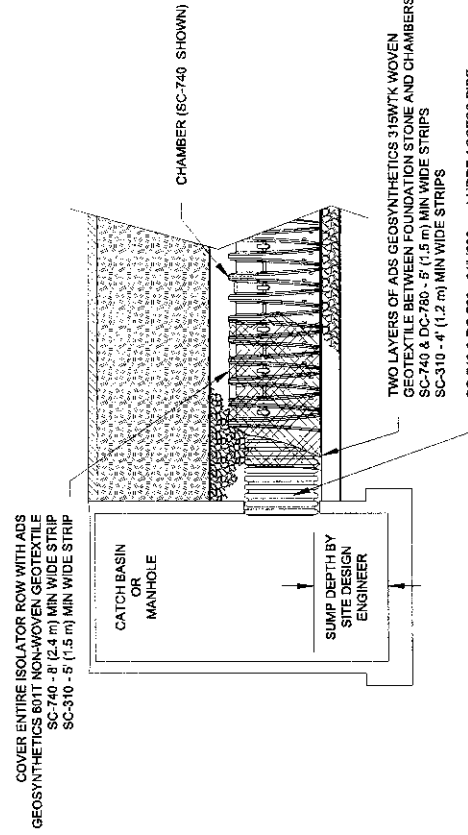

NOTE: NON-WOVEN GEOTEXTILE OVER DC-780 ISOLATOR ROW CHAMBERS IS NOT REQUIRED.

Table 1 - Acceptable Fill Materials

Material Type	Material Description	Material Specifications	Installation Notes
Final Fill	Final Fill: Fill Material for layer 'D' starts from the top of the 'C' layer to the bottom of flexible pavement or unpaved finished grade above. Note that the pavement subbase may be part of the 'D' layer.	Any soil/rock materials, native soils or per engineer's plans. Check plans for pavement subgrade requirements.	Prepare per site design engineer's plans. Paved installations may have stringent material and preparation requirements.
Initial Fill	Initial Fill: Fill Material for layer 'C' starts from the top of the embankment stone (6" layer) to 18" (450 mm) above the top of the chamber. Note that pavement subbase may be part of the 'C' layer.	Granular well-graded soil/ aggregate mixtures, <35% fines or processed aggregate. Must be used in lieu of this layer.	Begin compaction after min. 12" (300 mm) of material over the chambers is reached. Compact additional layers in 6" (150 mm) max. lifts to a min. 95% Proctor density for well-graded material and 95% relative density for processed aggregate materials. Roller gross vehicle weight not to exceed 12,000 lbs (53 kN). Dynamic force not to exceed 20,000 lbs (89 kN).
Embankment Stone	Embankment Stone surrounding chambers from the foundation stone to the 'C' layer above.	Clean, crushed, angular stone	No compaction required.
Foundation Stone	Foundation Stone below the chambers from the subgrade up to the top (bottom) of the chamber.	Clean, crushed, angular stone.	Place and compact in 6" (150 mm) lifts using two full coverages with a vibratory compactor. ^{2,3}

NOTES:

1. The listed AASHTO designations are for gradations only. The stone must also be clean, crushed, angular. For example, a specification for #4 stone would state: "clean, crushed, angular no. 4 (AASHTO M43) stone".
2. StormTech compaction requirements are met for 'A' location materials when placed and compacted in 6" (150 mm) lifts using two full coverages with a vibratory compactor.
3. Where infiltration surfaces may be compromised by compaction, for standard installations and standard design load conditions, a flat surface may be achieved by raking or dragging without compaction equipment. For special load weights, contact StormTech for compaction requirements.

Figure 2 - Fill Material Locations

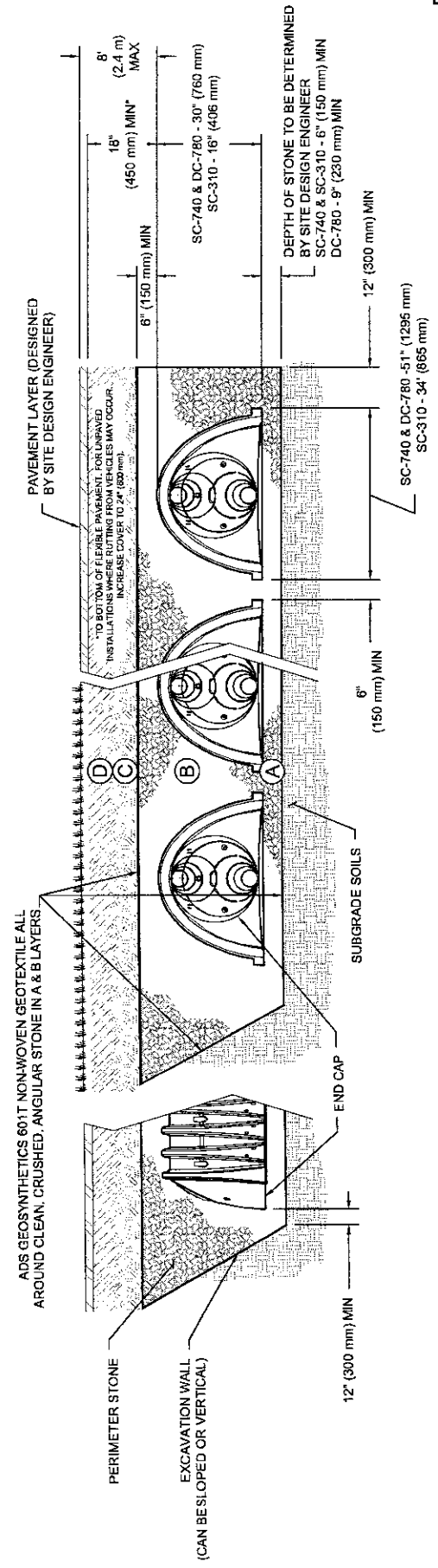
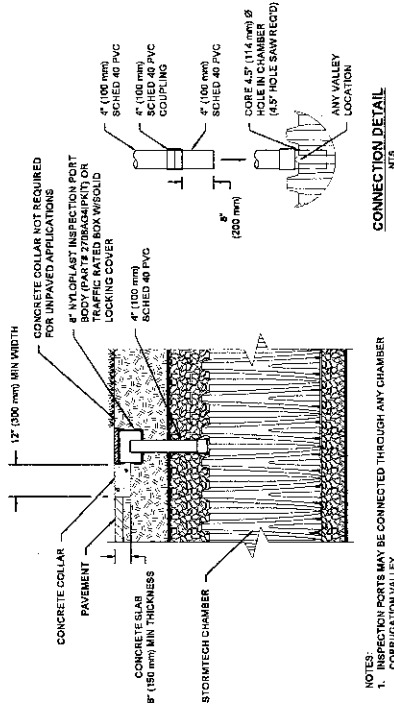

Figure 1 - Inspection Port Detail



- NOTES:
1. INSPECTION PORTS MAY BE CONNECTED THROUGH ANY CHAMBER
 2. ALL SCHEDULE 40 FITTINGS TO BE SOLVENT CEMENTED (4\"/>

Table 2 - Maximum Allowable Construction Vehicle Loads*

Material	Final Fill Material	Initial Fill Material	Embedment Stone	Foundation Stone	Maximum Allowable Construction Vehicle Loads*		Maximum Allowable Construction Vehicle Loads*	
					Final Fill Material	Initial Fill Material	Embedment Stone	Foundation Stone
36" (900) Compacted	32,000 [142]	16,000 [71]	12" (305) 18" (457) 24" (610) 30" (762) 36" (914)	3420 [164] 2350 [113] 1850 [89] 1510 [72] 1310 [63]	38,000 [169]			
24" (600) Compacted	32,000 [142]	16,000 [71]	12" (305) 18" (457) 24" (610) 30" (762) 36" (914)	2480 [119] 1770 [85] 1490 [68] 1210 [56] 1070 [51]	20,000 [89]			
24" (600) Loose/Dumped	32,000 [142]	16,000 [71]	12" (305) 18" (457) 24" (610) 30" (762) 36" (914)	2245 [107] 1625 [76] 1325 [63] 1136 [54] 1010 [48]	20,000 [89]	Roller gross vehicle weight not to exceed 12,000 lbs. [53 kN]		
18" (450)	32,000 [142]	16,000 [71]	12" (305) 18" (457) 24" (610) 30" (762) 36" (914)	2010 [96] 1480 [71] 1220 [58] 1060 [51] 950 [45]	20,000 [89]	Roller gross vehicle weight not to exceed 12,000 lbs. [53 kN]		
12" (300)	16,000 [71]	NOT ALLOWED	12" (305) 18" (457) 24" (610) 30" (762) 36" (914)	1540 [74] 1190 [57] 1010 [48] 910 [43] 840 [40]	20,000 [89]	Roller gross vehicle weight not to exceed 12,000 lbs. [53 kN]		
6" (150)	8,000 [35]	NOT ALLOWED	12" (305) 18" (457) 24" (610) 30" (762) 36" (914)	1070 [51] 900 [43] 800 [36] 760 [36] 720 [34]	NOT ALLOWED			

Table 3 - Placement Methods and Descriptions

Material	Final Fill Material	Initial Fill Material	Embedment Stone	Foundation Stone	Placement Methods and Descriptions
Final Fill Material	A variety of placement methods may be used. All construction loads must not exceed the maximum limits in Table 2.	Excavator positioned off bed recommended. Small excavator allowed over chambers. Small dozer allowed.	No equipment allowed on bare chambers. Use excavator or stone conveyor positioned off bed or on foundation stone to evenly fill around all chambers to at least the top of chambers.	No StormTech restrictors. Contractor responsible for any conditions or requirements for any conditions or requirements by others relative to subgrade bearing capacity, dewatering or protection of subgrade.	Roller travel parallel to rows only until 36" (900 mm) compacted cover is reached.
Initial Fill Material	Excavator positioned off bed recommended. Small excavator allowed over chambers. Small dozer allowed.	Asphalt can be dumped into paver when compacted pavement substrate reaches 18" (450 mm) above top of chambers.	No wheel bars allowed. Material must be placed outside the limits of the chamber bed.	No rollers allowed.	Use dynamic force of roller only after compacted fill depth reaches 12" (300 mm) over chambers. Roller travel parallel to chamber rows only.
Embedment Stone	No equipment allowed on bare chambers. Use excavator or stone conveyor positioned off bed or on foundation stone to evenly fill around all chambers to at least the top of chambers.	No wheel bars allowed. Material must be placed outside the limits of the chamber bed.	No tracked equipment is allowed on chambers until a min. 6" (150 mm) cover stone is in place.		
Foundation Stone	No StormTech restrictors. Contractor responsible for any conditions or requirements for any conditions or requirements by others relative to subgrade bearing capacity, dewatering or protection of subgrade.				

NOTES:

- 36" (900 mm) of stabilized cover materials over the chambers is required for full dump truck travel and dumping.
- During paving operations, dump truck axle loads on 18" (450 mm) of cover may be necessary. Precautions should be taken to avoid rutting of the road base layer, to ensure that compaction requirements have been met, and that a minimum of 18" (450 mm) of cover exists over the chambers. Contact StormTech for additional guidance on allowable axle loads during paving.
- Ground pressure for track dozers is the vehicle operating weight divided by total ground contact area for both tracks. Excavators will exert higher ground pressures based on loaded bucket weight and boom extension.
- Mini-excavators (< 8,000 lbs./3,628 kg) can be used with at least 12" (300 mm) of stone over the chambers and are limited by the maximum ground pressures in Table 2 based on a full bucket at maximum boom extension.
- Storage of materials such as substitution materials, equipment, spalls, etc. should not be located over the StormTech system. The use of equipment over the StormTech system not covered in Table 2 (e.g. any mining equipment, cranes, etc.) is limited. Please contact StormTech for more information.
- Allowable track loads based on vehicle travel only. Excavator shall not operate on chamber beds until the total backfill reaches 3 feet (900 mm) over the entire bed.

ADS "Terms and Conditions of Sale" are available on the ADS website, www.ads-pipe.com. Advanced Drainage Systems, the ADS logo, and the green stripe are registered trademarks of Advanced Drainage Systems, Inc. StormTech® and the Isolator® Row are registered trademarks of StormTech, Inc #11010 07/19 CS

©2019 Advanced Drainage Systems, Inc.

STANDARD LIMITED WARRANTY OF STORMTECH LLC ("STORMTECH"): PRODUCTS

- (A) This Limited Warranty applies solely to the StormTech chambers and end plates manufactured by StormTech and sold to the original purchaser (the "Purchaser"). The chambers and end plates are collectively referred to as the "Products."
- (B) The structural integrity of the Products, when installed strictly in accordance with StormTech's written installation instructions at the time of installation, are warranted to the Purchaser against defective materials and workmanship for one (1) year from the date of purchase. Should a defect appear in the Limited Warranty period, the Purchaser shall provide StormTech with written notice of the alleged defect at StormTech's corporate headquarters within ten (10) days of the discovery of the defect. The notice shall describe the alleged defect in reasonable detail. StormTech agrees to supply replacements for those Products determined by StormTech to be defective and covered by this Limited Warranty. The supply of replacement products is the sole remedy of the Purchaser for breaches of this Limited Warranty. StormTech's liability specifically excludes the cost of removal and/or installation of the Products.
- (C) **THIS LIMITED WARRANTY IS EXCLUSIVE. THERE ARE NO OTHER WARRANTIES WITH RESPECT TO THE PRODUCTS, INCLUDING NO IMPLIED WARRANTIES OF MERCHANTABILITY OR OF FITNESS FOR A PARTICULAR PURPOSE.**
- (D) This Limited Warranty only applies to the Products when the Products are installed in a single layer. **UNDER NO CIRCUMSTANCES, SHALL THE PRODUCTS BE INSTALLED IN A MULTI-LAYER CONFIGURATION.**
- (E) No representative of StormTech has the authority to change this Limited Warranty in any manner or to extend this Limited Warranty. This Limited Warranty does not apply to any person other than to the Purchaser.
- (F) Under no circumstances shall StormTech be liable to the Purchaser or to any third party for product liability claims; claims arising from the design, shipment, or installation of the Products, or the cost of other goods or services related to the purchase and installation of the Products. For this Limited Warranty to apply, the Products must be installed in accordance with all site conditions required by state and local codes; all other applicable laws; and StormTech's written installation instructions.
- (G) **THE LIMITED WARRANTY DOES NOT EXTEND TO INCIDENTAL, CONSEQUENTIAL, SPECIAL OR INDIRECT DAMAGES. STORMTECH SHALL NOT BE LIABLE FOR PENALTIES OR LIQUIDATED DAMAGES, INCLUDING LOSS OF PRODUCTION AND PROFITS; LABOR AND MATERIALS; OVERHEAD COSTS; OR OTHER LOSS OR EXPENSE INCURRED BY THE PURCHASER OR ANY THIRD PARTY. SPECIFICALLY EXCLUDED FROM LIMITED WARRANTY COVERAGE ARE DAMAGE TO THE PRODUCTS ARISING FROM ORDINARY WEAR AND TEAR; ALTERATION, ACCIDENT, MISUSE, ABUSE OR NEGLIGENCE; THE PRODUCTS BEING SUBJECTED TO VEHICLE TRAFFIC OR OTHER CONDITIONS WHICH ARE NOT PERMITTED BY STORMTECH'S WRITTEN SPECIFICATIONS OR INSTALLATION INSTRUCTIONS; FAILURE TO MAINTAIN THE MINIMUM GROUND COVERS SET FORTH IN THE INSTALLATION INSTRUCTIONS; THE PLACEMENT OF IMPROPER MATERIALS INTO THE PRODUCTS; FAILURE OF THE PRODUCTS DUE TO IMPROPER SITING OR IMPROPER SIZING; OR ANY OTHER EVENT NOT CAUSED BY STORMTECH. A PRODUCT ALSO IS EXCLUDED FROM LIMITED WARRANTY COVERAGE IF SUCH PRODUCT IS USED IN A PROJECT OR SYSTEM IN WHICH ANY GEOTEXTILE PRODUCTS OTHER THAN THOSE PROVIDED BY ADVANCED DRAINAGE SYSTEMS ARE USED. THIS LIMITED WARRANTY REPRESENTS STORMTECH'S SOLE LIABILITY TO THE PURCHASER FOR CLAIMS RELATED TO THE PRODUCTS, WHETHER THE CLAIM IS BASED UPON CONTRACT, TORT, OR OTHER LEGAL THEORY.**



An  company

20 Beaver Road, Suite 104 | Wethersfield | Connecticut | 06109

888.892.2694 fax 866.328.8401

www.stormtech.com



ADS GEOSYNTHETICS 0601T NONWOVEN GEOTEXTILE

Scope

This specification describes ADS Geosynthetics 6.0 oz (0601T) nonwoven geotextile.

Filter Fabric Requirements

ADS Geosynthetics 6.0 oz (0601T) is a needle-punched nonwoven geotextile made of 100% polypropylene staple fibers, which are formed into a random network for dimensional stability. ADS Geosynthetics 6.0 oz (0601T) resists ultraviolet deterioration, rotting, biological degradation, naturally encountered basics and acids. Polypropylene is stable within a pH range of 2 to 13. ADS Geosynthetics 6.0 oz (0601T) conforms to the physical property values listed below:

Filter Fabric Properties

PROPERTY	TEST METHOD	UNIT	M.A.R.V. (Minimum Average Roll Value)
Weight (Typical)	ASTM D 5261	oz/yd ² (g/m ²)	6.0 (203)
Grab Tensile	ASTM D 4632	lbs (kN)	160 (0.711)
Grab Elongation	ASTM D 4632	%	50
Trapezoid Tear Strength	ASTM D 4533	lbs (kN)	60 (0.267)
CBR Puncture Resistance	ASTM D 6241	lbs (kN)	410 (1.82)
Permittivity*	ASTM D 4491	sec ⁻¹	1.5
Water Flow*	ASTM D 4491	gpm/ft ² (l/min/m ²)	110 (4480)
AOS*	ASTM D 4751	US Sieve (mm)	70 (0.212)
UV Resistance	ASTM D 4355	%/hrs	70/500

PACKAGING	
Roll Dimensions (W x L) – ft	12.5 x 360 / 15 x 300
Square Yards Per Roll	500
Estimated Roll Weight – lbs	195

* At the time of manufacturing. Handling may change these properties.



ADS GEOSYNTHETICS 315W WOVEN GEOTEXTILE

Scope

This specification describes ADS Geosynthetics 315W woven geotextile.

Filter Fabric Requirements

ADS Geosynthetics 315W is manufactured using high tenacity polypropylene yarns that are woven to form a dimensionally stable network, which allows the yarns to maintain their relative position. ADS Geosynthetics 315W resists ultraviolet deterioration, rotting and biological degradation and is inert to commonly encountered soil chemicals. ADS Geosynthetics 315W conforms to the physical property values listed below:

Filter Fabric Properties

PROPERTY	TEST METHOD	ENGLISH M.A.R.V. (Minimum Average Roll Value)	METRIC M.A.R.V. (Minimum Average Roll Value)
Tensile Strength (Grab)	ASTM D-4632	315 lbs	1400 N
Elongation	ASTM D-4632	15%	15%
CBR Puncture	ASTM D-6241	900 lbs	4005 N
Puncture	ASTM D-4833	150 lbs	667 N
Mullen Burst	ASTM D-3786	600 psi	4134 kPa
Trapezoidal Tear	ASTM D-4533	120 lbs	533 N
UV Resistance (at 500 hrs)	ASTM D-4355	70%	70%
Apparent Opening Size (AOS)*	ASTM D-4751	40 US Std. Sieve	0.425 mm
Permittivity	ASTM D-4491	.05 sec ⁻¹	.05 sec ⁻¹
Water Flow Rate	ASTM D-4491	4 gpm/ft ²	163 l/min/m ²
Roll Sizes		12.5' x 360' 15.0' x 300' 17.5' x 258'	3.81 m x 109.8 m 4.57 m x 91.5 m 5.33 m x 78.6 m

*Maximum average roll value.