

338605

When recorded mail to:

City Clerk's Office
City of Riverside
City Hall, 3900 Main Street
Riverside, California 92522

FREE RECORDING

This instrument is for the benefit of the City of Riverside and is entitled to be recorded without fee (Government Code 6103)

RECEIVED FOR RECORD
Min. Past 2 o'clock P

NCV 181988

Recorded in Official Records
of Riverside County, California

RECORDER
Fees \$
1/1/88

FOR RECORDER'S OFFICE USE ONLY

Project: PMW-39-867
Copley Lane

E A S E M E N T

FOR VALUABLE CONSIDERATION, receipt of which is hereby acknowledged, DANIEL M. GOMEZ and MARY GOMEZ, husband and wife as joint tenants as Grantors, grant to the CITY OF RIVERSIDE, a municipal corporation, as Grantee, its successors and assigns, an easement and right-of-way for the construction, reconstruction, maintenance, operation, inspection, repair, replacement, relocation, renewal and removal of storm drain facilities, together with all necessary appurtenances, in, under, upon, over and along that certain real property situated in the City of Riverside, County of Riverside, State of California, described as follows:

The southwesterly 6.8 feet of Lot 28, Tract No. 8685, as shown by map on file in Book 155, Pages 32 and 33 of Maps, records of Riverside County, California, together with the northeasterly 3.2 feet of Lot 36, Tract No. 4278, as shown by map on file in Book 72, Pages 61 and 62 of Maps, records of said Riverside County.

TOGETHER WITH the right to clear and keep clear said easement and right-of-way from any structures or trees, to enter upon and to pass and repass over and along said property, and to deposit tools, implements and other material thereon by Grantee, its officers, agents and employees and by persons under contract with said Grantee and their officers, agents and employees, whenever and wherever necessary for the purpose of constructing, reconstructing, maintaining, operating, inspecting, repairing, replacing, relocating, renewing and removing said storm drain facilities.

Dated NOV 3, 1988

DANIEL M. GOMEZ
MARY GOMEZ

338605

CONSENT TO RECORDATION

THIS IS TO CERTIFY that the interest in real property conveyed by the within instrument to the City of Riverside, California, a municipal corporation, is hereby accepted by the undersigned officer on behalf of the City Council of said City pursuant to authority conferred by Resolution No. 14883 of said City Council adopted January 25, 1983, and the grantee consents to recordation thereof by its duly authorized officer.

Dated _____

Title _____

0001u/m - 0140u/a

DESCRIPTION APPROVAL 11/3/88
George P. Hutchinson by h-1
SURVEYOR, CITY OF RIVERSIDE



APPROVED AS TO FORM
Robert A. Saus 11/9
ASST. CITY ATTORNEY

STATE OF CALIFORNIA }
COUNTY OF RIVERSIDE } ss.

On this 3rd day of NOVEMBER, in the year 1988, before me, the undersigned, a Notary Public in and for said State, personally appeared DANIEL M. GOMEZ AND MARY GOMEZ

_____, personally known to me (or proved to me on the basis of satisfactory evidence) to be the person whose name S ARE subscribed to the within instrument, and acknowledged to me that the y executed it.

WITNESS my hand and official seal.

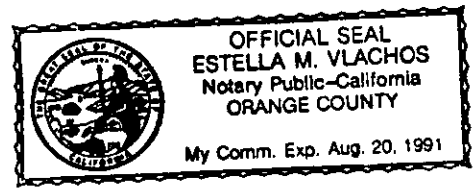

Estella M. Vlachos
Notary Public in and for said State.
ESTELLA M. VLACHOS

338605

E COPLEY LANE

33'

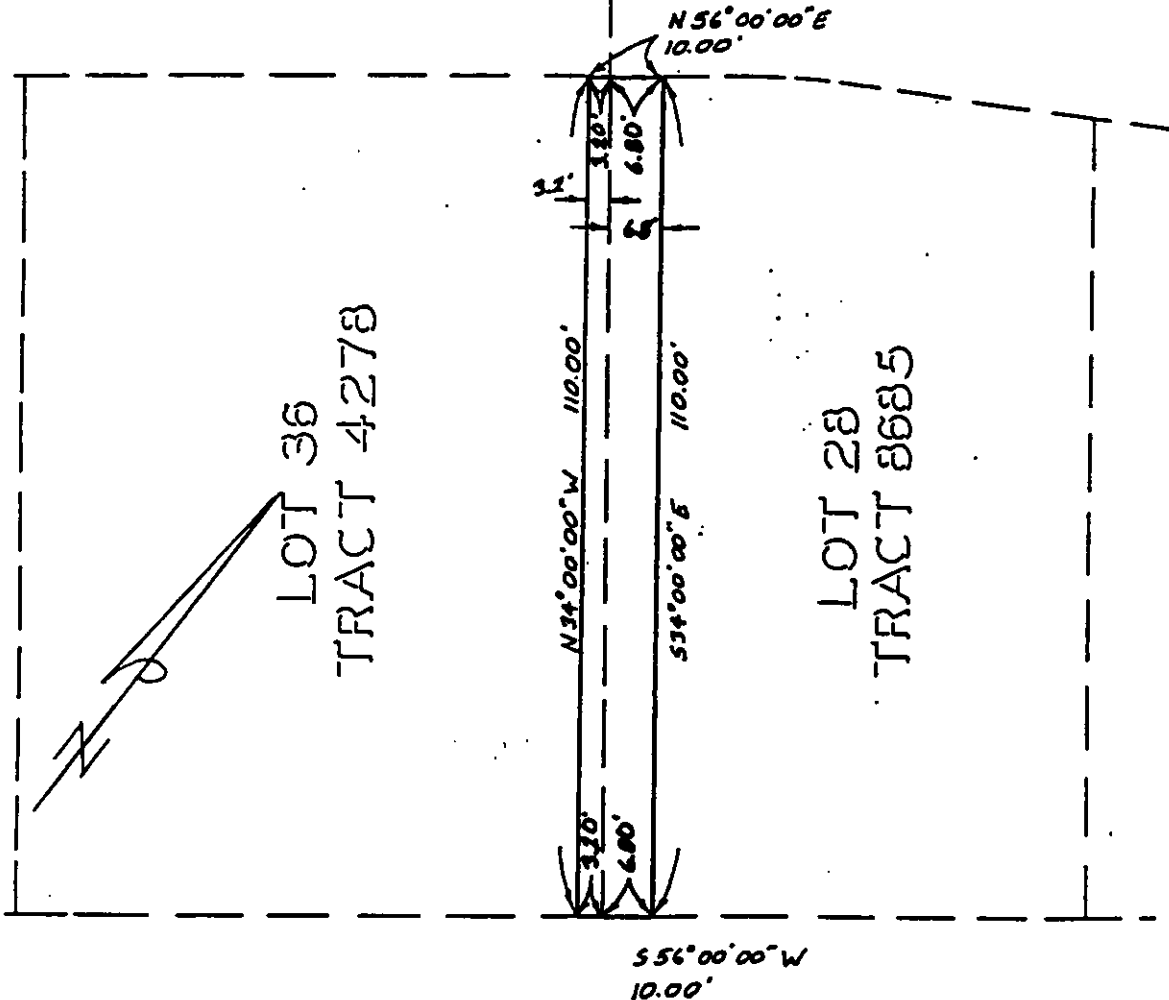

• CITY OF RIVERSIDE, CALIFORNIA •

THIS PLAT IS SOLELY AN AID IN LOCATING THE PARCEL(S) DESCRIBED IN THE ATTACHED DOCUMENT. IT IS NOT A PART OF THE WRITTEN DESCRIPTION THEREIN.

SHEET 1 OF 1

S/44-1

SCALE: 1" = N.T.S.

DRAWN BY D.A. DATE 9/14/88

SUBJECT PMW-39-867 S.D. EASEMENT