

When recorded mail to:
 City Clerk's Office
 City of Riverside
 City Hall, 3900 Main Street
 Riverside, California 92522

DOC # 2002-165497
 04/01/2002 08:00A Fee:NC
 Page 1 of 6
 Recorded in Official Records
 County of Riverside
 Gary L. Orso
 Assessor, County Clerk & Recorder

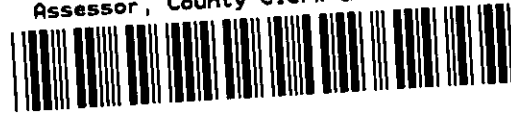

FREE RECORDING
 This instrument is for the benefit
 of the City of Riverside and is
 entitled to be recorded without
 fee (Government Code §6103)

M	S	U	PAGE	SIZE	DA	PCOR	NOCOR	SMF	MISC.
			1						
								✓	AS
A	R	L			COPY	LONG	REFUND	NCHG	EXAM

FOR RECORDER'S OFFICE USE ONLY

C
AS

Project: *Tract 29087-1*
Offsite Sewer Easements

D - 14869

EASEMENT

FOR VALUABLE CONSIDERATION, receipt of which is hereby acknowledged, **GHG RIVERWALK, LLC, a California Limited Liability Company**, grantor, grants to the CITY OF RIVERSIDE, a municipal corporation of the State of California, as Grantee, its successors and assigns, an easement and right-of-way for the construction, reconstruction, maintenance, operation, inspection, repair, replacement, relocation, renewal and removal of **sanitary sewer facilities**, together with all necessary appurtenances, in, under, upon, over and along that certain real property as described in **Exhibit "A"** attached hereto and incorporated herein by this reference, located in the City of Riverside, County of Riverside, State of California.

TOGETHER WITH the right to clear and keep clear said easement and right-of-way from any structures or trees, to enter upon and to pass and repass over and along said real

property, and to deposit tools, implements and other material thereon by Grantee, its officers, agents and employees and by persons under contract with said Grantee and their officers, agents and employees, whenever and wherever necessary for the purpose of constructing, reconstructing, maintaining, operating, inspecting, repairing, replacing, relocating, renewing and removing said **sanitary sewer facilities**.

Dated March 21, 2002

**GHG RIVERWALK, LLC, a California
Limited Liability Company**

**By: The Griffin Homebuilding Group, LLC,
a Delaware Limited Liability Company
its Managing Member**

**By: Griffin Industries, Inc.,
a California corporation,
Its Managing Member**

By: 
Paul E. Griffin, III, President

2

(7)

2002-165497
04/01/2002 08:00A
2 of 6



T290871swr

GENERAL ACKNOWLEDGEMENT

State of California

County of Los Angeles } ss

On March 21, 2002 before me [Signature] SONJA F. TSAI (name)

a Notary Public in and for said State, personally appeared

Paul E. Griffin, III Name(s) of Signer(s)

[X] personally known to me - OR - [] proved to me on the basis of satisfactory evidence to be the person(s) whose name(s) is/are subscribed to the within instrument and acknowledged to me that he/she/they executed the same in his/her/their authorized capacity(ies), and that by his/her/their signature(s) on the instrument the person(s), or the entity upon behalf of which the person(s) acted, executed the instrument.

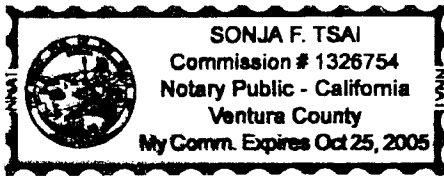

WITNESS my hand and official seal.

[Signature] Signature

OPTIONAL SECTION

CAPACITY CLAIMED BY SIGNER

() Attorney-in-fact
() Corporate Officer(s)
Title
Title

() Guardian/Conservator
() Individual(s)
() Trustee(s)
() Other

() Partner(s)
() General
() Limited

The party(ies) executing this document is/are representing:

CERTIFICATE OF ACCEPTANCE (Government Code Section 27281)

THIS IS TO CERTIFY that the interest in real property conveyed by the within instrument to the City of Riverside, California, a municipal corporation, is hereby accepted by the undersigned officer on behalf of the City Council of said City pursuant to authority conferred by Resolution No. 18233 of said City Council adopted May 11, 1993, and the grantee consents to recordation thereof by its duly authorized officer.

Dated 3/27/02

APPROVED AS TO FORM CITY ATTORNEY'S OFFICE

[Signature] Real Property Services Manager of the City of Riverside

BY [Signature] Deputy City Attorney

2002-165497 64/61/2002 68:65A 3 of 6



EXHIBIT "A"

THOSE PORTIONS OF LOT 13, TRACT NO. 29058 IN THE CITY OF RIVERSIDE, AS SHOWN BY MAP ON FILE IN BOOK 289, PAGES 27 THROUGH 36 INCLUSIVE, RECORDS OF THE COUNTY OF RIVERSIDE, CALIFORNIA BEING A STRIP OF LAND 15 FEET IN WIDTH, THE CENTERLINE BEING MORE PARTICULARLY DESCRIBED AS FOLLOWS:

STRIP 1

COMMENCING AT THE MOST SOUTHERLY CORNER OF LOT 7, SAID CORNER ALSO BEING ON THE NORTHWESTERLY RIGHT OF WAY OF SCHUYLER AVENUE AVENUE, 73.00 FEET WIDE, AS SHOWN ON SAID TRACT 29058;

THENCE SOUTH 56°49'50" WEST A DISTANCE OF 3.57 FEET ALONG SAID RIGHT OF WAY, TO A POINT OF INTERSECTION OF SAID NORTHWESTERLY RIGHT OF WAY WITH THE SOUTHWESTERLY RIGHT OF WAY OF GOLDEN AVENUE (84.00 FEET WIDE) AS SHOWN ON SAID TRACT 29058;

THENCE SOUTH 34°17'49" EAST ALONG SAID SOUTHWESTRLY RIGHT OF WAY A DISTANCE OF 36.37 FEET TO THE TRUE POINT OF BEGINNING;

THENCE SOUTH 56°35'02 WEST A DISTANCE OF 87.51 FEET TO A POINT HEREINAFTER REFERRED TO AS POINT "A";

THENCE SOUTH 55°42'11" WEST A DISTANCE OF 80.82 FEET TO A POINT HEREINAFTER REFERRED TO AS POINT "B";

THENCE SOUTH 48°14'00" WEST A DISTANCE OF 44.95 FEET;

THENCE SOUTH 04°09'35" WEST A DISTANCE OF 63.90 FEET TO A POINT HEREINAFTER REFERRED TO AS POINT "C";

THENCE SOUTH 69°21'00" WEST A DISTANCE OF 11.21 FEET, SAID POINT BEING THE TERMINUS OF HEREIN DESCRIBED STRIP OF LAND.

THE SIDELINES OF SAID STRIP SHALL BE PROLONGED OR SHORTENED TO TERMINATE ON SAID SOUTHWESTERLY LINE OF GOLDEN AVENUE.

STRIP 2

BEING A STRIP OF LAND 15.00 FEET IN WIDTH, THE CENTERLINE OF WHICH IS DESCRIBED AS FOLLOWS:

BEGINNING AT ABOVE DESCRIBED POINT "A";

THENCE SOUTH 34°17'49" EAST A DISTANCE OF 13.50 FEET TO THE TERMINUS OF HEREIN DESCRIBED STRIP OF LAND.

EXCEPTING THEREFROM THAT PORTION THEREOF LYING WITHIN ABOVE DESCRIBED STRIP 1.



2002-165497
04/01/2002 08:00A
4 of 6

STRIP 3

BEING A STRIP OF LAND 15.00 FEET IN WIDTH, THE CENTERLINE OF WHICH IS DESCRIBED AS FOLLOWS:

BEGINNING AT ABOVE DESCRIBED POINT "B";

THENCE NORTH 34°17'49" WEST A DISTANCE OF 14.47 FEET TO THE TERMINUS OF HEREIN DESCRIBED STRIP OF LAND.

EXCEPTING THEREFROM THAT PORTION THEREOF LYING WITHIN ABOVE DESCRIBED STRIP 1.

STRIP 4

BEING A STRIP OF LAND 15.00 FEET IN WIDTH, THE CENTERLINE OF WHICH IS DESCRIBED AS FOLLOWS:

BEGINNING AT ABOVE DESCRIBED POINT "C";

THENCE SOUTH 61°58'47" EAST A DISTANCE OF 16.06 FEET TO THE TERMINUS OF HEREIN DESCRIBED STRIP OF LAND.

EXCEPTING THEREFROM THAT PORTION THEREOF LYING WITHIN ABOVE DESCRIBED STRIP 1.

DAVID EVANS AND ASSOCIATES, INC.

Randall Lee Ward 3-7-02
RANDALL LEE WARD DATE
P.L.S. NO. 7653, EXPIRES 12/31/04

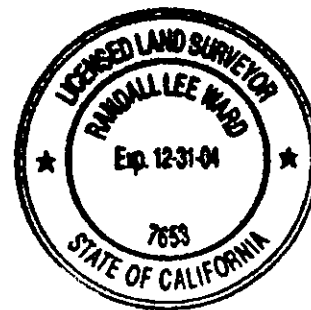

DESCRIPTION: APPROVAL 3/19/02
Walter R. Ince by _____
for SURVEYOR, CITY OF RIVERSIDE



2002-165497
04/01/2002 08:00A
5 of 6

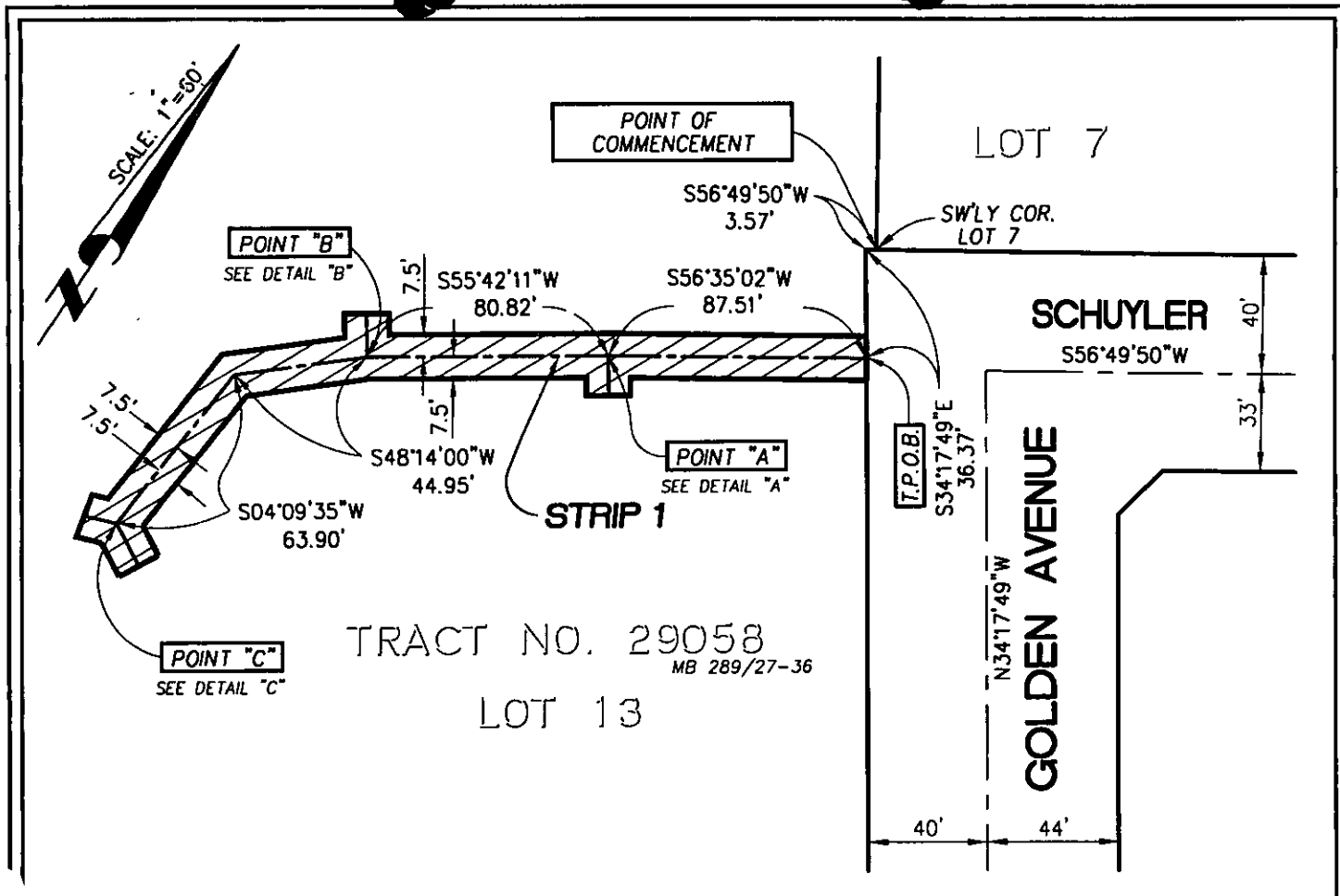

TRACT NO. 29058
 MB 289/27-36
 LOT 13

DETAIL "A"
 SCALE: 1" = 40'

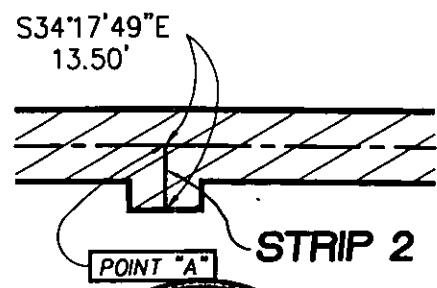

DETAIL "B"
 SCALE: 1" = 40'

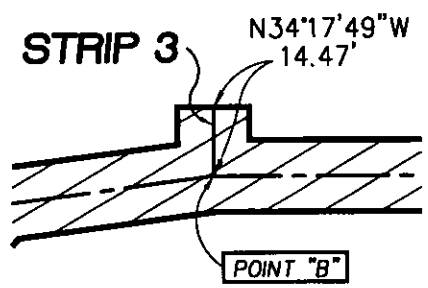

INDICATES EASEMENT AREA

DETAIL "C"
 SCALE: 1" = 40'

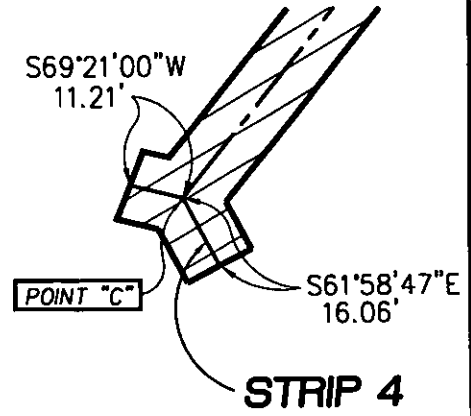

2002-165437
 04/01/2002 08:00A
 6 of 6



**DAVID EVANS
 AND ASSOCIATES INC.**
 800 NORTH HAVEN AVENUE, SUITE 300
 ONTARIO, CALIFORNIA 91764
 TEL: (909) 481-5750
 FAX: (909) 481-5757

**EXHIBIT
 "B"**

RIVERSIDE COUNTY, CALIFORNIA
 CITY OF RIVERSIDE
**15' WIDE SEWER LINE
 EASEMENT**

CLIENT:
GRIFFIN INDUSTRIES

SHEET NO.	1 OF 1
JOB NO.	GRIF0001
DRAWN BY:	SLB
DATE:	03-05-02
SCALE:	AS NOTED

63/8 78/2
 14809