

FILE COPY
4-15-64

EASEMENT GRANT DEED

WILLIAM JOSEPH FROLICH and ANN FROLICH, husband and wife

(Grantors - Grantors)

FOR A VALUABLE CONSIDERATION, receipt of which is hereby acknowledged, do _____
hereby grant to the CITY OF RIVERSIDE, a municipal corporation, the real property in the
City of Riverside, County of Riverside, State of California, described as follows: --

An easement for road purposes over the southwesterly
7.00 feet of the northeasterly 172.00 feet of the south-
easterly 330.00 feet of the southwesterly rectangular 5.00
acres of Lot 5, Block 66 of Land of W.T. Sayward and
S.C. Evans, as shown by map on file in Book 3, page 2 of
Maps, Records of San Bernardino County, California.

RECORDED APR. 22. 64.
BOOK 3672 PAGE 426
OFFICIAL RECORDS, INC. (C)
INSTRUMENT NO. 49377

Dated APR. 16 19 64

(S) _____
William Joseph Frolich
(S) _____
Ann Frolich

BLOCK

56

LOT

5

MA
REC
PAI
SUE
CIT
RC

PARCEL 2

Northeast
5 Acres of

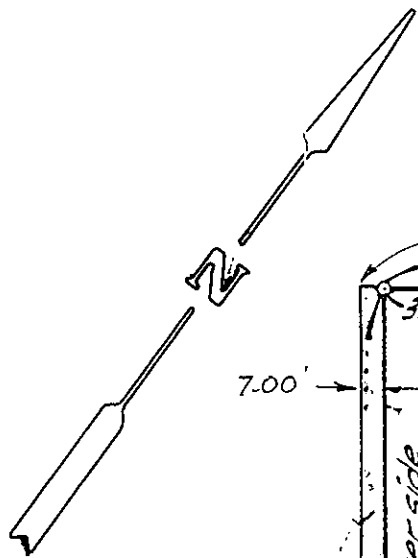

7.00'

172.00'

S 55° 58' 00" W 165.00'

33.00'

132.00'

660.88'

7' easement for Roadway
to be deeded to the City of Riverside

S 33° 59' 15" E 330.00'

330.00'

PARCEL 1

330.00'

N 33° 59' 15" W

7.00'

33.00'

132.00'

Fd. 2X2
with tack

LINCOLN

N 55° 58' 00" E

165.00'

1192.70

165.00'

40.00'

AVE

Set & S&T

Set & S&T

CITY OF RIVERSIDE, CALIFORNIA

PLAT OF PARCEL(S) DESCRIBED
IN THE ATTACHED DOCUMENT

This plat is solely an aid in locating the parcel(s) described in the
attached document. It is not a part of the written description therein.

SCALE

1" = 60'

DRAWN 4 15 '64 BY HLP

SUBJECT R/S 814

4930 5/36