

ENCROACHMENT PERMIT

Pursuant to Resolution No. 11065 of the City of Riverside, permission is hereby granted to WESTERN MUNICIPAL WATER DISTRICT OF RIVERSIDE COUNTY
6377 Riverside Avenue (P.O. Box 2038)
Riverside, CA 92506

its heirs and assigns, hereinafter referred to as "Permittee" to use and occupy the following described property.

That portion of Alessandro Boulevard, a public right of way, lying within the South 1/2 of Section 8, Township 3 South, Range 4 West, San Bernardino Meridian,

in accordance with the terms hereof.

1. Permittee shall use and occupy the described property only in the manner and for the purposes as follows: To construct and maintain a water line encroaching into said public right of way a maximum of 9.00 feet as shown by Exhibit "A" attached and made a part hereof by this reference.

a) This Encroachment Permit is being issued temporarily while the City negotiates a franchise with the Permittee.

2. Permittee, by acceptance of the benefits hereunder, acknowledges title to the property to be in the City of Riverside and waives any right to contest the validity of the dedication or grant.

E-9

3. Permittee acknowledges that the described property is the site of a proposed or planned public improvement and that, accordingly, all rights and privileges of use permitted shall cease and expire upon notice of revocation by the City. Upon the expiration or revocation, Permittee shall, within the time prescribed by the City, remove all improvements or obstructions placed, constructed or maintained by the Permittee. If the Permittee fails to abide by the removal order of the City within the time prescribed, the City shall have the right to remove and destroy the improvements without reimbursement to the Permittee and the cost of such removal shall be paid by the Permittee to the City of Riverside and shall constitute a debt owed to the City of Riverside.

4. Permittee, by acceptance hereof, waives the right of claim, loss, damage or action against the City of Riverside arising out of or resulting from revocation, termination, removal of the improvements or any action of the City of Riverside, its officers, agents or employees taken in accordance with the terms hereof.

5. Finding and determination by the City Council of the City of Riverside that the Permittee, or his heirs and assigns or successors in interest, are in default of the terms hereunder shall be cause for revocation.

6. Permittee herewith agrees to hold the City of Riverside harmless from and against all claims, demands, costs, losses, damages, injuries, action for damages and/or injuries, and liability growing or arising out of or in connection with the construction, encroachment, and/or maintenance to be done by Permittee or his agents, employees or contractors within the described property.

DATED: Nov 8, 1984

CITY OF RIVERSIDE, a municipal corporation

By [Signature] Mayor

Attest [Signature] City Clerk

The foregoing is accepted by:

[Signature]
(Signature(s) of Permittee)
Assistant General Manager

APPROVED AS TO CONTENT

[Signature]
Department Head

APPROVED AS TO FORM

[Signature]
City Attorney

CITY MANAGER APPROVAL

[Signature]
City Manager

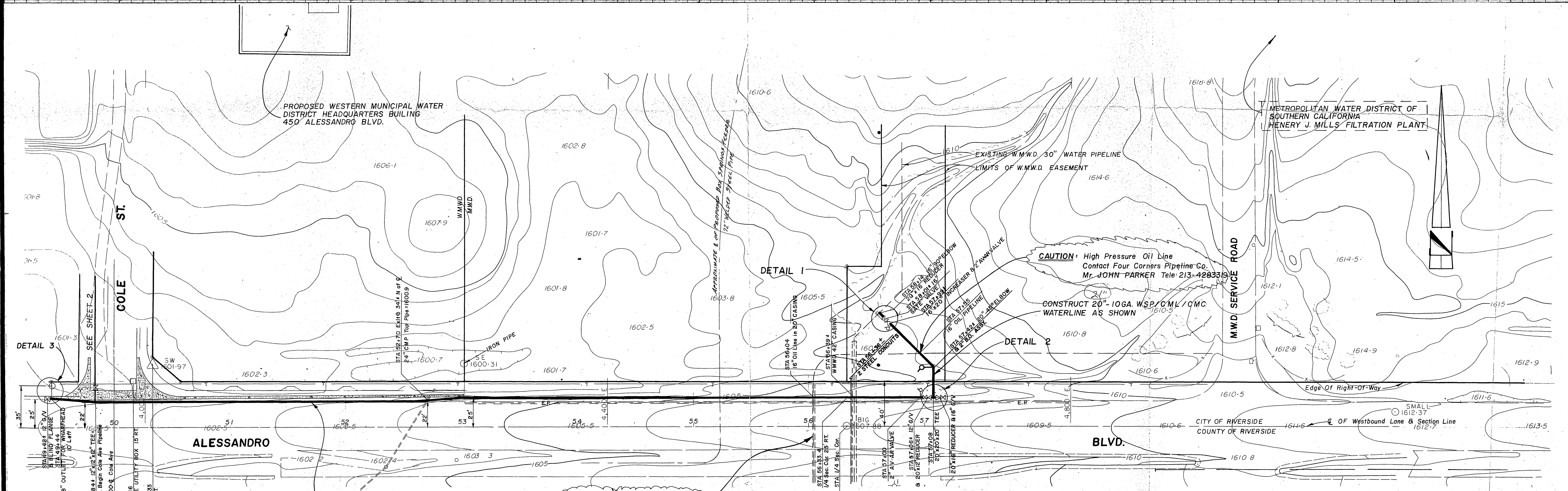
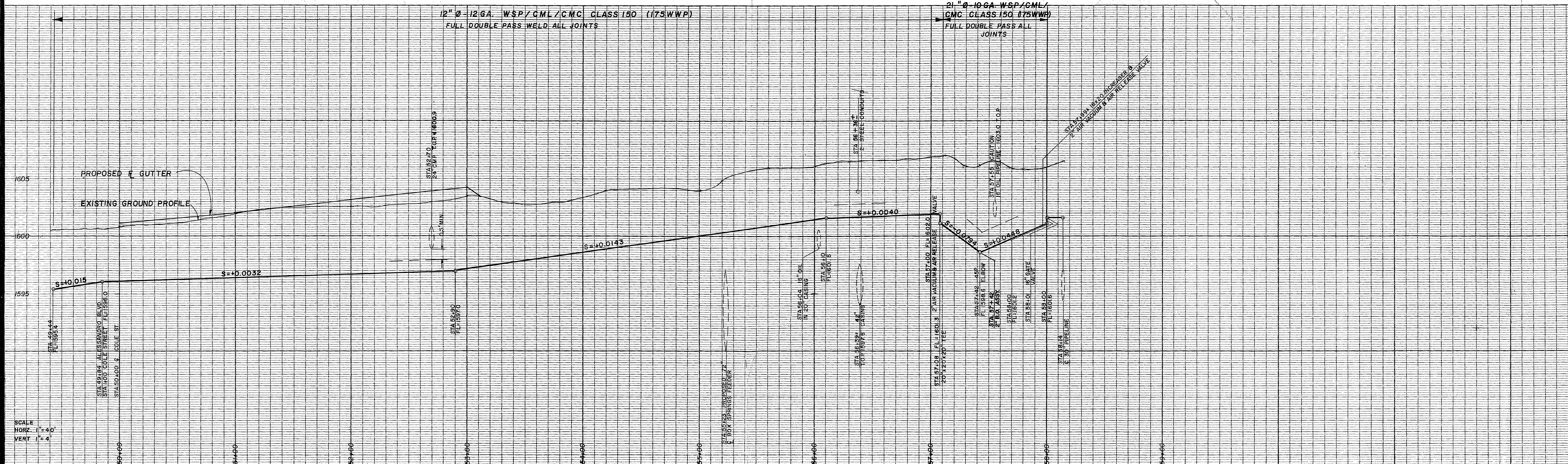

<p>SCALE HORIZ. 1" = 40' VERT. 1" = 4'</p>		<p>12" Ø - 12 GA. WSP/CML/CMC CLASS 150 (175 WWP) FULL DOUBLE PASS WELD ALL JOINTS</p>		<p>20" Ø - 10 GA. WSP/CML/CMC CLASS 150 (175 WWP) FULL DOUBLE PASS ALL JOINTS</p>	
<p>SCALE HORIZ. 1" = 40' VERT. 1" = 4'</p>		<p>PROPOSED WESTERN MUNICIPAL WATER DISTRICT HEADQUARTERS BUILDING 450 ALESSANDRO BLVD.</p>		<p>METROPOLITAN WATER DISTRICT OF SOUTHERN CALIFORNIA HENRY J. MILLS FILTRATION PLANT</p>	
<p>CONSTRUCT 12" - 12 GA. WSP/CML/CMC WATERLINE AS SHOWN.</p>		<p>CONSTRUCT 20" - 10 GA. WSP/CML/CMC WATERLINE AS SHOWN.</p>		<p>CAUTION: High Pressure Oil Line Contact Four Corners Pipeline Co. Mr. JOHN PARKER Tele: 213-4283319</p>	
<p>WESTERN MUNICIPAL WATER DISTRICT OF RIVERSIDE COUNTY</p>		<p>ALESSANDRO BLVD HEADQUARTERS PIPELINE</p>		<p>SCALE 1" = 40' HORIZ. DATE August 84 DRAWN [Signature] CHECKED [Signature]</p>	
<p>APPROVED BY: [Signature] CHIEF ENGINEER RCB 17984</p>		<p>GENERAL MANAGER [Signature]</p>		<p>SHEET 1 OF 2 DRAWING NO. WD-159</p>	
<p>NO. DESCRIPTION APPR. DATE</p>		<p>REVISIONS</p>		<p>NO. DESCRIPTION APPR. DATE</p>	

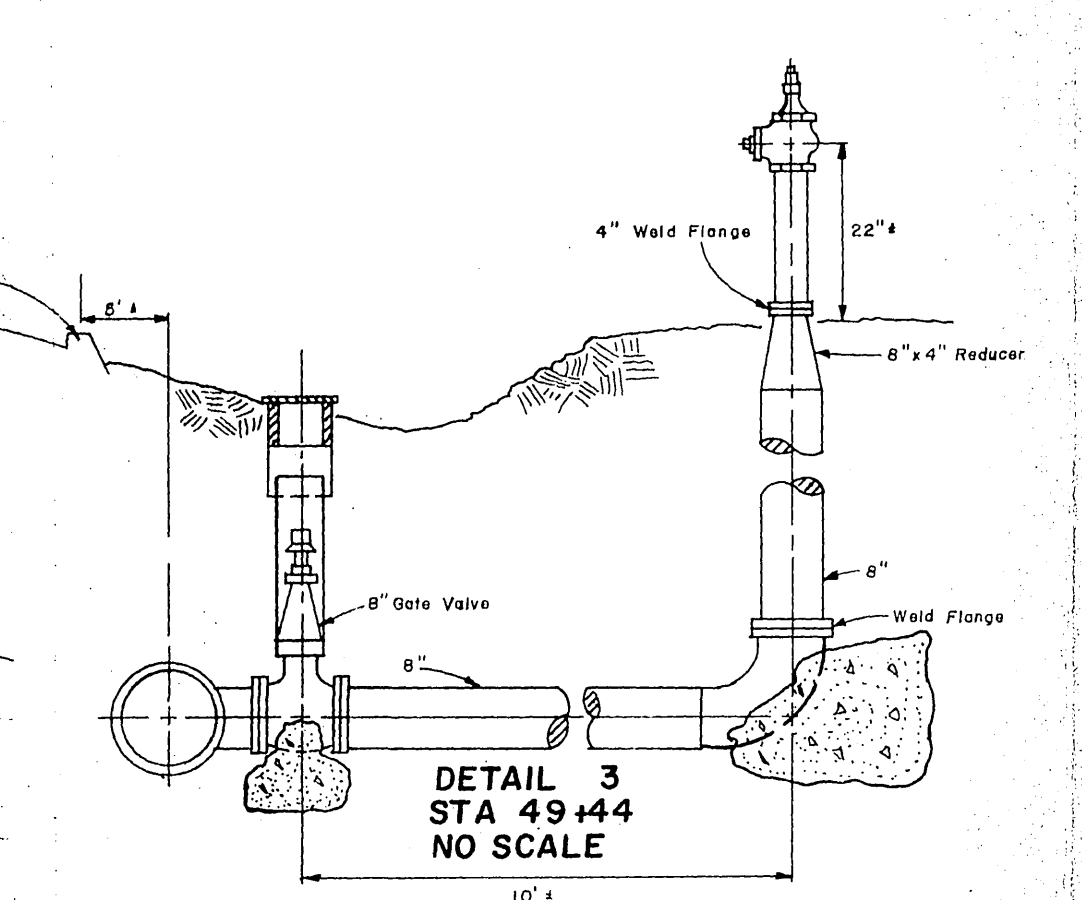
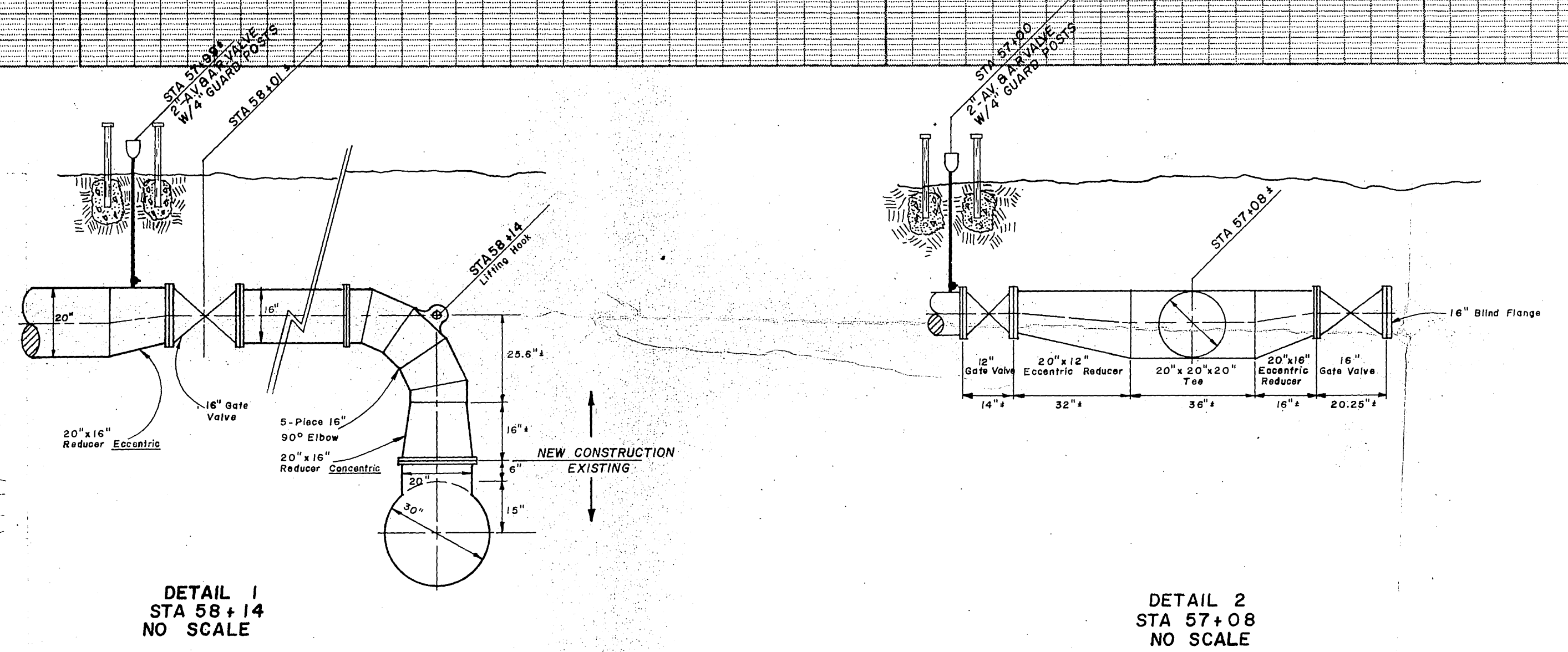
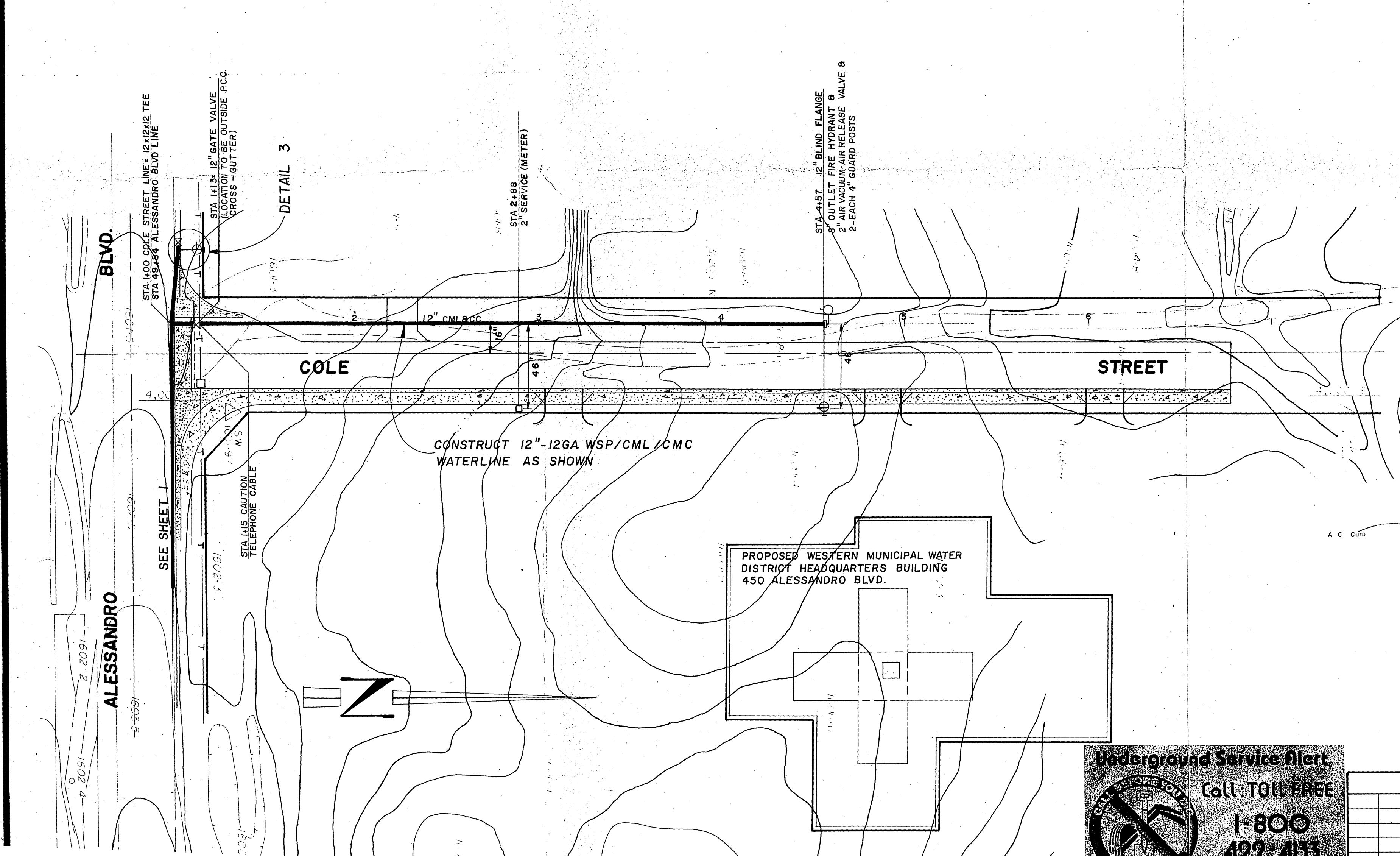
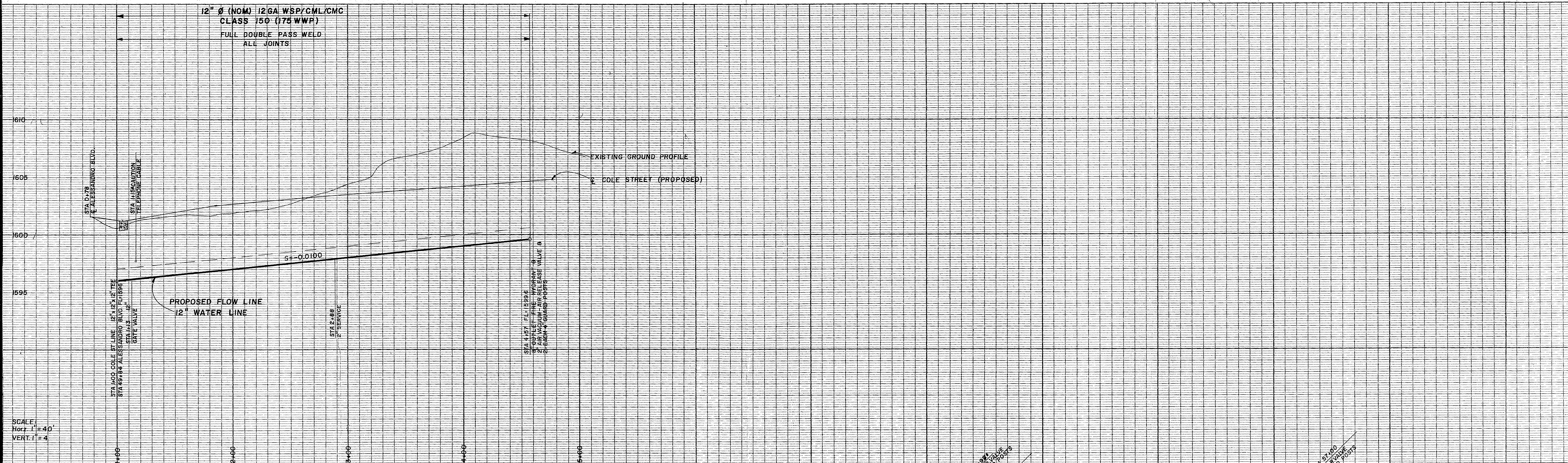

NO.	DESCRIPTION	APPR.	DATE

WESTERN MUNICIPAL WATER DISTRICT
OF RIVERSIDE COUNTY

APPROVED BY: *David W. Howe* Aug 15, 1984
CHIEF ENGINEER P.C.E. 17984

David W. Howe
GENERAL MANAGER

ALESSANDRO BLVD
HEADQUARTERS PIPELINE

SCALE: H=40' V=4'
DATE: JULY 1984
DRAWN: *ASB*
CHECKED: *THS*

SHEET 2 OF 2
DRAWING NO. *WD-159*