

Copy

SHEET 1 OF 2 SHEETS

# RECORD OF SURVEY

IN THE CITY OF RIVERSIDE,  
RIVERSIDE COUNTY, CALIFORNIA  
OF ALL OF PARCEL 2 OF PARCEL MAP 13044  
AS SHOWN PER MAP ON FILE IN BOOK 109 OF  
PARCEL MAPS, AT PAGES 66 THROUGH 68, RE-  
CORDS OF RIVERSIDE COUNTY, CALIFORNIA.  
JULY 1985 SCALE: 1"=100'

J. F. DAVIDSON ASSOCIATES

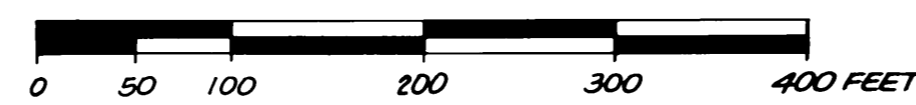

**RECORDER'S CERTIFICATE**  
FILED THIS 27th DAY OF FEBRUARY 1986 AT 1:30 P.M.  
IN BOOK 15 OF RECORDS OF SURVEY, AT PAGE 2163 AT  
THE REQUEST OF THE COUNTY SURVEYOR.  
NO. 45846  
FEE \$ 800

WILLIAM E. CONERLY, COUNTY RECORDER  
BY: Carita Pagan DEPUTY

### COUNTY SURVEYOR'S STATEMENT

THIS MAP HAS BEEN EXAMINED IN ACCORDANCE WITH  
SECTION 8766 OF THE LAND SURVEYOR'S ACT THIS  
26th DAY OF FEB 1986.



LeRoy D. Smoot, COUNTY SURVEYOR  
BY: Gerald Adreon DEPUTY  
L.S. 3739

### SURVEYOR'S STATEMENT

THIS MAP CORRECTLY REPRESENTS A SURVEY MADE BY ME  
OR UNDER MY DIRECTION IN CONFORMANCE WITH THE RE-  
QUIREMENTS OF THE LAND SURVEYOR'S ACT AT THE  
REQUEST OF HUGHES INVESTMENTS IN JULY, 1985.

James F. Davidson, Jr.  
JAMES F. DAVIDSON, JR. L.S. 3018

### SURVEYOR'S NOTES

- INDICATES FOUND MONUMENT AS NOTED.
  - INDICATES SET 1" IRON PIPE WITH PLASTIC PLUG STAMPED L.S. 3018, FLUSH, UNLESS OTHERWISE NOTED.
  - ( ) INDICATES MEASURED AND RECORD DATA PER PARCEL MAP 13044, P.M.B. 109/66-68, UNLESS OTHERWISE NOTED.
- BASIS OF BEARINGS: BEARINGS ARE BASED ON THE CENTER-LINE OF CENTRAL AVENUE AS SHOWN ON MAP IN BOOK 109 OF PARCEL MAPS AT PAGES 66 THROUGH 68, RECORDS OF RIVERSIDE COUNTY, CALIFORNIA.
- N.A.P. INDICATES "NOT A PART."

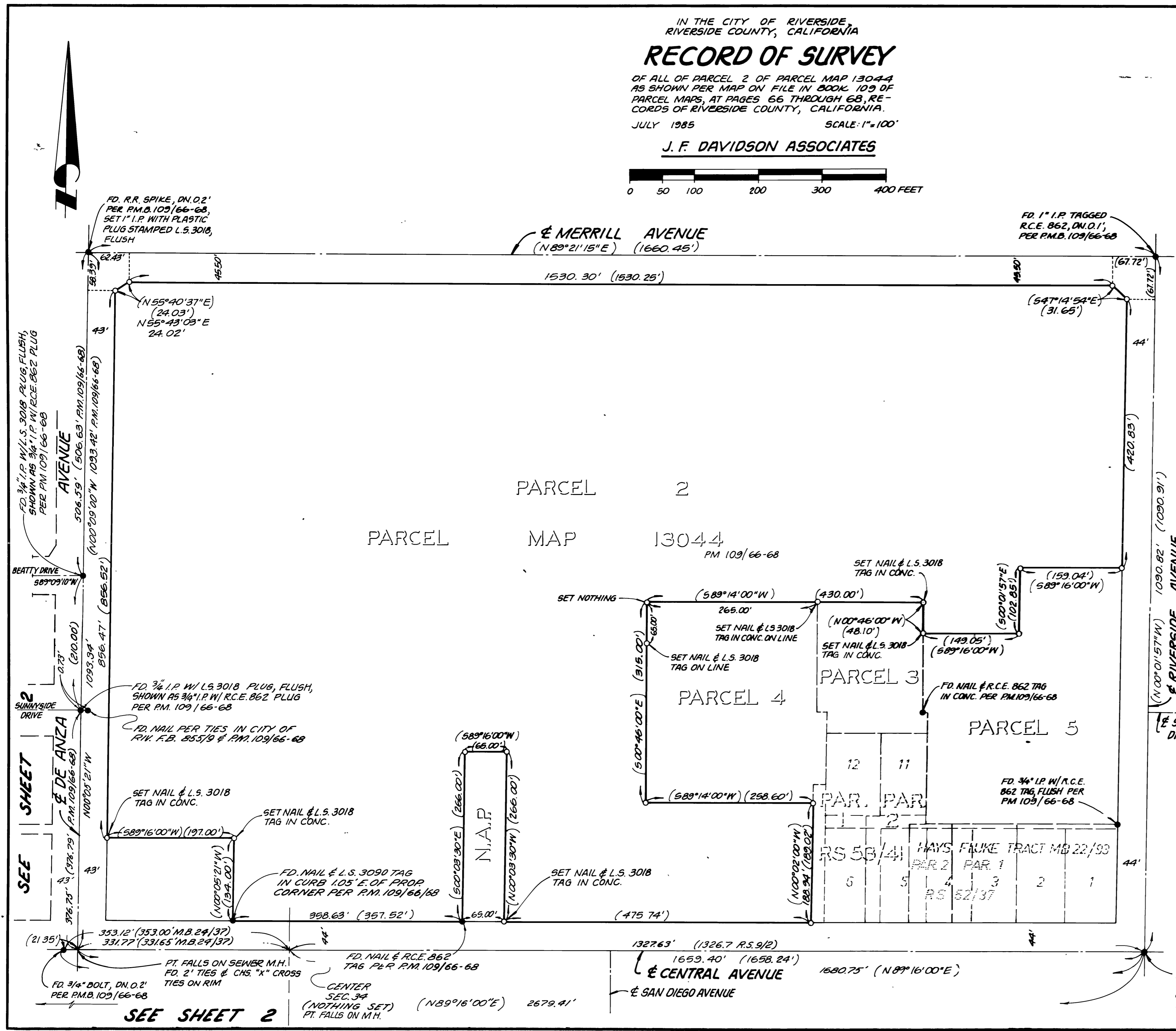

RS 75/62

SEE SHEET 2

32-2-5W RIV. CO. 86-08 W.D. 85-8875

RS 75/62

copy 75/63

# RECORD OF SURVEY

OF ALL OF PARCEL 2 OF PARCEL MAP 13044 AS SHOWN PER MAP ON FILE IN BOOK 109 OF PARCEL MAPS, AT PAGES 66 THROUGH 68, RECORDS OF RIVERSIDE COUNTY, CALIFORNIA.

OCTOBER 1985

SCALE: 1"=100'

J.F. DAVIDSON ASSOCIATES



PARCEL MAP 13044  
P.M. 109/66-68



(SEE SHEET No. 1 FOR SURVEYOR'S NOTES)

RS 75/63

RS 75/63

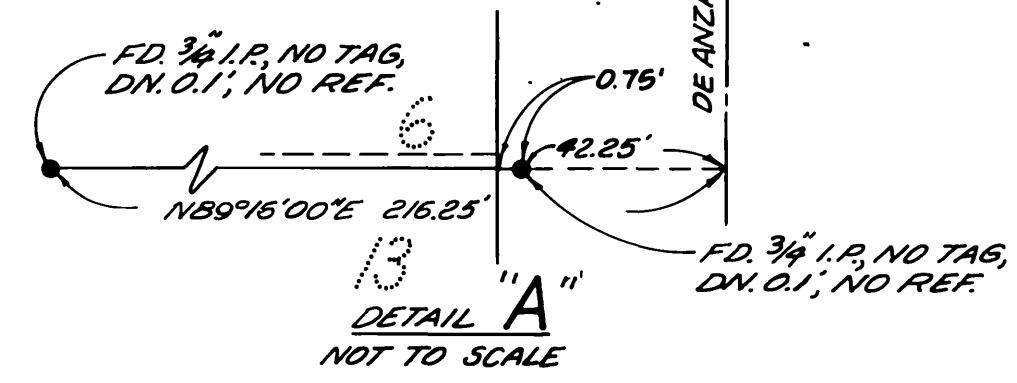
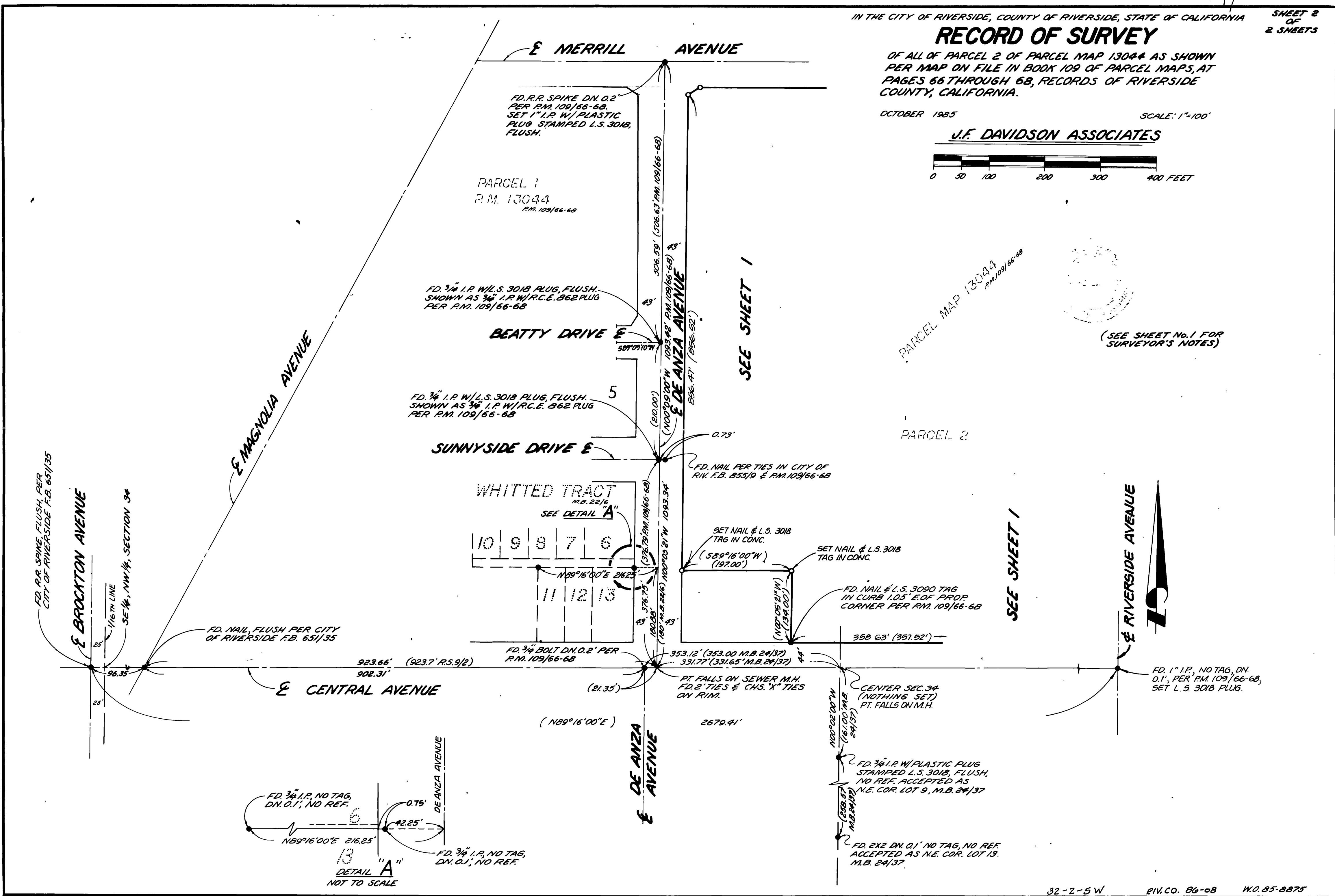

SEE SHEET 1

SEE SHEET 1

RS 75/63