

SEWER IMPROVEMENT PLANS IN THE CITY OF RIVERSIDE FOR TRACT No. 30741

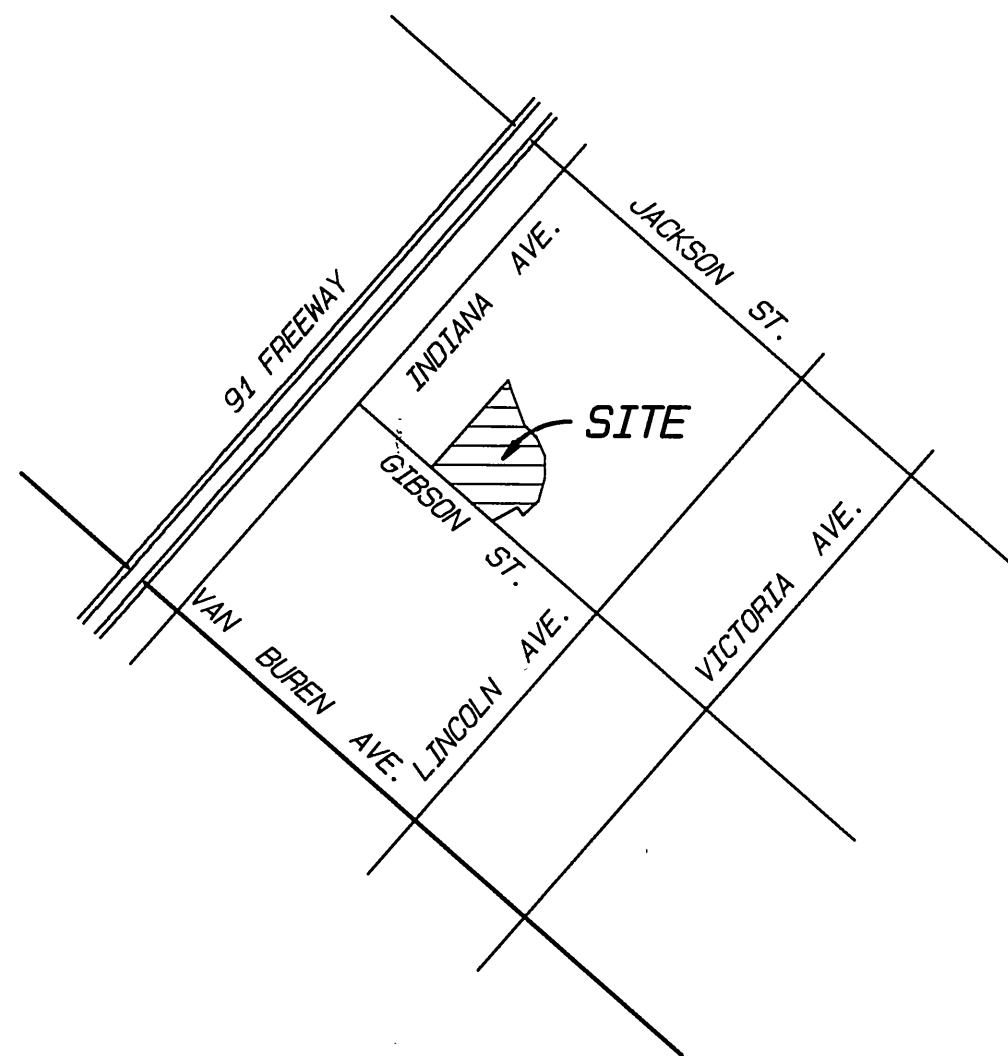

VICINITY MAP

SCALE: 1" = 100'

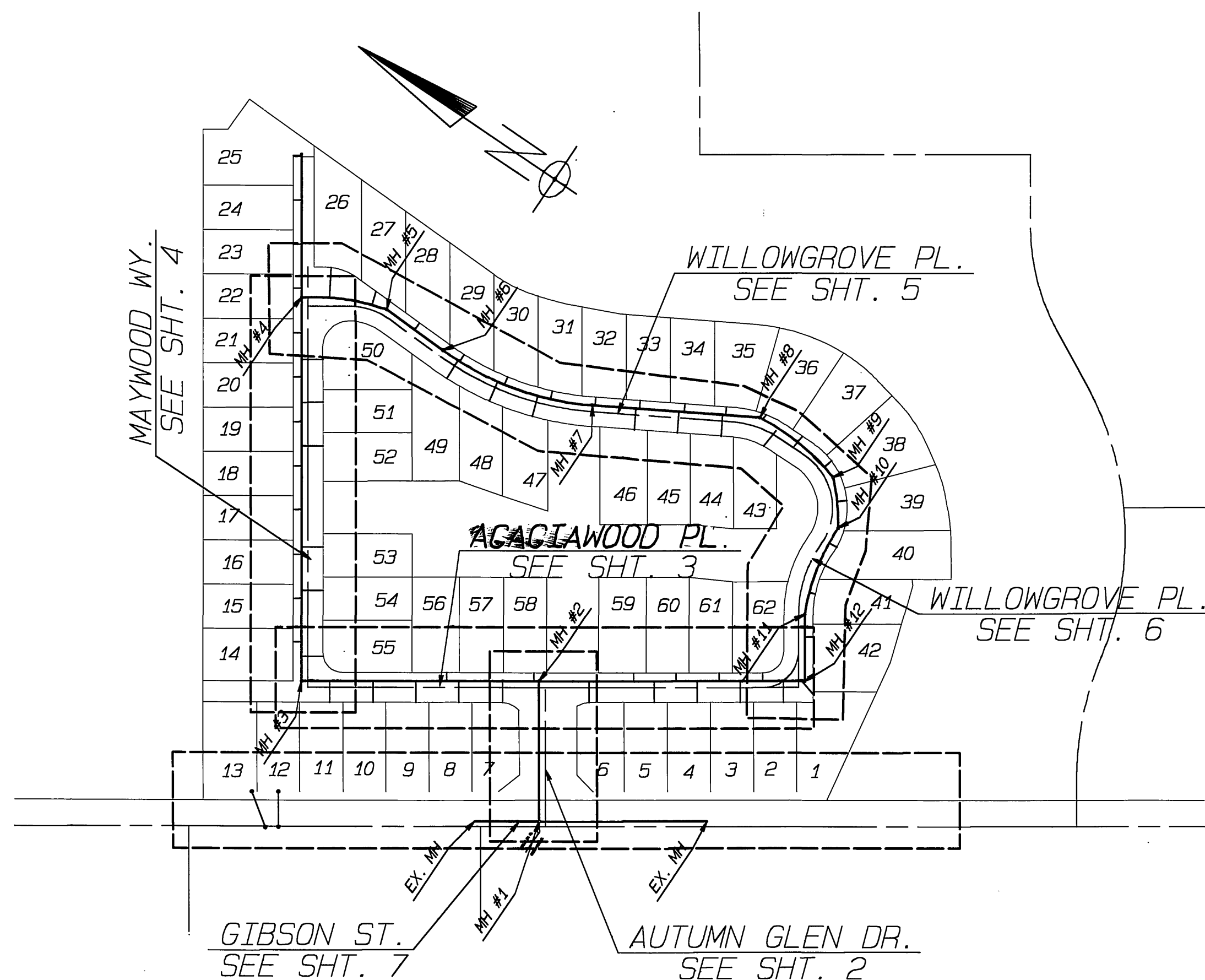

INDEX MAP

SCALE: 1" = 100'

GENERAL NOTES

- IT SHALL BE THE RESPONSIBILITY OF THE CONTRACTOR TO CLEAR THE RIGHT OF WAY IN ACCORDANCE WITH THE PROVISIONS OF LAW AS IT AFFECTS EACH UTILITY INCLUDING IRRIGATION LINES AND APPURTENANCES AND AT NO COST TO THE CITY.
- CONSTRUCTION SHALL BE IN ACCORDANCE WITH THE CITY OF RIVERSIDE DEPARTMENT OF PUBLIC WORKS, STANDARD DRAWINGS, ITS SUPPLEMENTAL NOTES AND THE STANDARD SPECIFICATIONS FOR PUBLIC WORKS CONSTRUCTION, CURRENT EDITION.
- THE PRIVATE ENGINEER SIGNING THESE PLANS IS RESPONSIBLE FOR ASSURING THE ACCURACY AND ACCEPTABILITY OF THE WORK HEREON. IN THE EVENT OF DISCREPANCIES ARISING DURING CONSTRUCTION, THE PRIVATE ENGINEER SHALL BE RESPONSIBLE FOR DETERMINING AN ACCEPTABLE SOLUTION AND REVISING THE PLANS FOR APPROVAL BY THE CITY.
- QUANTITIES SHOWN ARE FOR INFORMATION ONLY AND THE CITY OF RIVERSIDE IS NOT RESPONSIBLE FOR THEIR ACCURACY.
- THE DEVELOPER SHALL BE RESPONSIBLE FOR PRESERVING OR RE-ESTABLISHING AND REFERENCING SURVEY MONUMENTS DESTROYED, DISTURBED OR BURIED AS A RESULT OF CONSTRUCTION SHOWN HEREON.
- ALL FLAGGED ELEVATIONS SHALL BE STAKED IN THE FIELD BY THE PRIVATE ENGINEER.
- THE CONTRACTOR SHALL CALL IN A LOCATION REQUEST TO UNDERGROUND SERVICE ALERT (USA) PHONE No. 1-800-227-2600, TWO WORKING DAYS BEFORE DIGGING. NO CONSTRUCTION PERMIT WILL BE ISSUED BY THE PUBLIC WORKS DEPARTMENT INVOLVING EXCAVATION FOR UNDERGROUND FACILITIES UNLESS APPLICANT HAS BEEN PROVIDED AN INQUIRY IDENTIFICATION No. BY USA.
- THE CONTRACTOR IS TO VERIFY EXISTING SEWER ELEVATION PRIOR TO CONSTRUCTION.
- LOCATION OF LATERALS TO BE DETERMINED IN THE FIELD AT THE DIRECTION OF THE OWNER. AVOID CONFLICT WITH PROPOSED AND/OR EXISTING FACILITIES.
- NO FINISHED FLOOR ELEVATION SHALL BE LESS THAN 6" ABOVE THE UPPER MANHOLE RIM ELEVATION OF THE SEWER LINE SEGMENT BEING CONNECTED TO, WITHOUT HAVING A PROPER BACKWATER VALVE INSTALLED IN THE LATERAL.
- A PLUG SHALL BE INSTALLED AND WILL REMAIN IN PLACE WHERE THE NEW SEWER CONNECTS WITH THE EXISTING SEWER UNTIL THE NEW SEWER IS ACCEPTED BY THE CITY.
- THE SEWER CONTRACTOR SHALL ADJUST MANHOLES TO FINAL GRADE AFTER PAVING IS COMPLETED.
- NO PERSON SHALL PERFORM ANY CONSTRUCTION ACTIVITY OR INSTALL ANY OBJECTS WITHIN THE PUBLIC RIGHTS-OF-WAY OR EASEMENTS OF THE CITY OF RIVERSIDE WITHOUT A VALID CONSTRUCTION PERMIT OR A STREET OPENING PERMIT OR AN ENCROACHMENT PERMIT ISSUED BY THE CITY'S PUBLIC WORKS DEPARTMENT.

BENCHMARK

RIV. CO. B.M. F5-K3 ELEVATION = 836.398
PK NAIL W/ CITY ENGINEERS TAG IN THE NOSE OF THE CENTER MEDIAN ISLAND ALONG ADAMS ST. AT INDIANA AVE.

CONSTRUCTION NOTES AND QUANTITY ESTIMATE

- INSTALL 8" DIA. V.C.P. SEWER..... 2080 L.F.
BEDDING PER STD. 452, CASE 1
- CONSTRUCT MANHOLE..... 11 EA.
PER C/R STD. DWG. 500
- CONSTRUCT CLEANOUT..... 1 EA.
PER C/R STD. DWG. 560
- CONSTRUCT 4" DIA. SEWER LATERAL WITH P.L. C.O. . . . 800 L.F.
PER C/R STD. DWG. 562A (REFER TO GENERAL NOTE 9)
- LAY WYE AT SEWER MAIN FLAT PER C/R STD. 562, NOTE 3.

Underground Service Alert
Call: TOLL FREE
1-800
227-2600
TWO WORKING DAYS BEFORE YOU DIG

CITY OF RIVERSIDE
WATER SYSTEM
(FOR SHTS. 1-7)

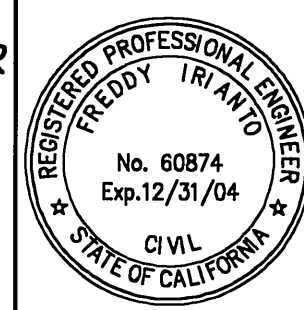

IW Consulting Engineers, Inc.
Civil Engineering
Surveying
Land Planning
3544 University Avenue
Riverside, CA 92501
Tel: 909.687.2929
Fax: 909.687.2989
RIVERSIDE BUSINESS TAX CERTIFICATE #1061592, EXP. 1/1/05

APPROVED BY: *Freddy Irianto*
FREDDY IRIANTO, PCE 60874, EXP 12/31/04
DATE: 5/24/04

MARK	REVISIONS	APPROVED DATE	APPROVED DATE
DESIGNED BY: JMB	DRAWN BY: FJE	CHECKED BY: RES	DESIGN ENGR. CITY ENGR.

CITY OF RIVERSIDE
PUBLIC WORKS DEPARTMENT

APPROVED BY	DATE	BY	APPROVED BY
PRINCIPAL ENGINEER	5/24/04	RES	<i>[Signature]</i>
PARK DEPARTMENT			CITY ENGINEER
TRAFFIC DIVISION			

DATE: 6-16-04

SEWER IMPROVEMENT PLAN
TRACT NO. 30741
TITLE SHEET

PW 03-0378
ACCOUNT NO.
S-1829
SHEET 1 OF 7
INCEL WORK ORDER: 108.005

INDEXED 7-19-04 lfh

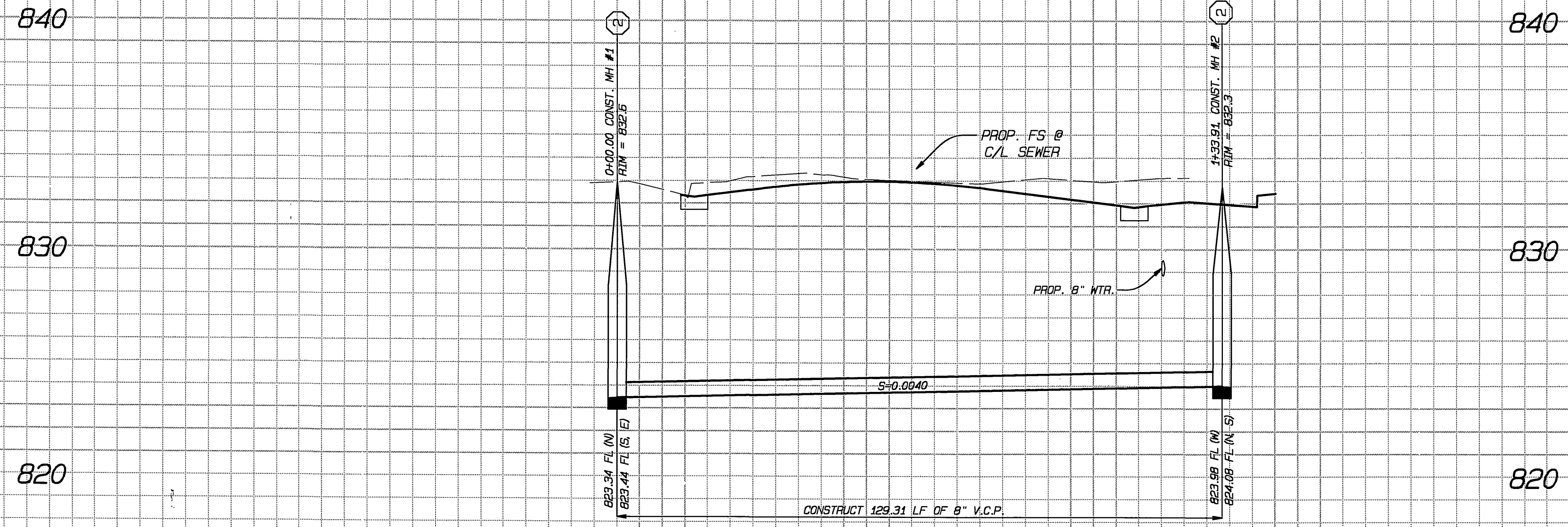

PROFILE SCALES	
HORIZONTAL	1" = 20'
VERTICAL	1" = 4'

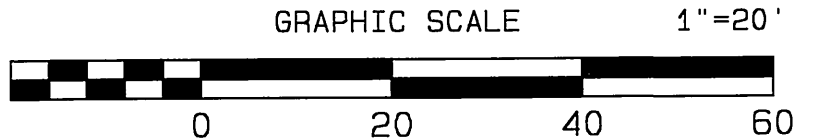
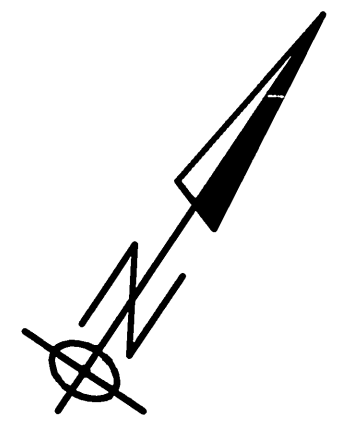
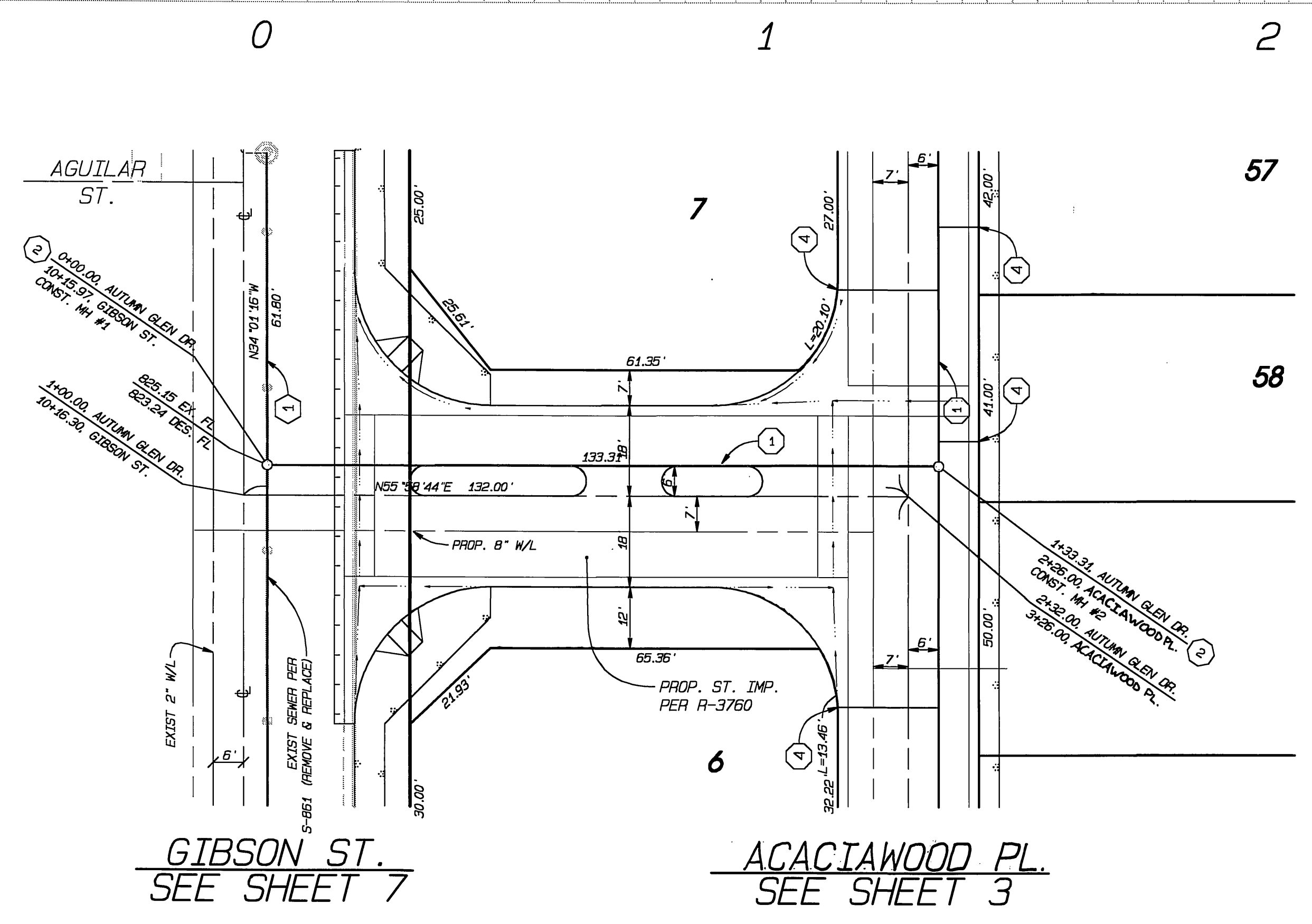

Underground Service Alert
 Call: TOLL FREE
 1-800-227-2600
 TWO WORKING DAYS BEFORE YOU DIG

BENCHMARK
 RIV. CO. B.M. FS-K3 ELEVATION = 836.398
 PK NAIL W/ CITY ENGINEERS TAG IN THE NOSE OF THE CENTER MEDIAN ISLAND ALONG ADAMS ST. AT INDIANA AVE.

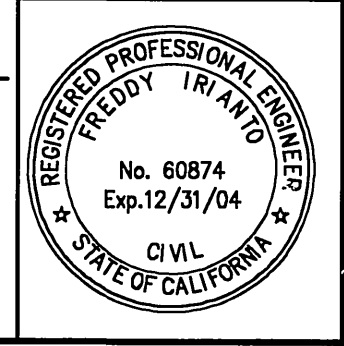

IW Consulting Engineers, Inc.
 Civil Engineering
 Surveying
 Land Planning
 3544 University Avenue
 Riverside, CA 92501
 Tel: 909.687.2929
 Fax: 909.687.2999
 RIVERSIDE BUSINESS TAX CERTIFICATE #106198, EXP. 1/1/05
 APPROVED BY: FREDDY IRIANTO, P.E. 60874, EXP. 12/31/04 DATE: 5/24/04

MARK	REVISIONS	APPROVED	DATE	APPROVED	DATE
DESIGNED BY:	DRAWN BY:	CHECKED BY:	DESIGN ENGR.:	CITY ENGR.:	

CITY OF RIVERSIDE
 PUBLIC WORKS DEPARTMENT
 APPROVED BY: [Signature] DATE: 6/16/04
 PRINCIPAL ENGINEER
 PARK DEPARTMENT
 TRAFFIC DIVISION
 APPROVED BY: [Signature] DATE: 6/16/04
 CITY ENGINEER

SEWER PLAN & PROFILE
 TRACT NO. 30741
AUTUMN GLEN DR.
 HORIZONTAL SCALE: 1" = 20' VERTICAL SCALE: 1" = 4'

PW 03-0378
 ACCOUNT NO. S-1829
 SHEET 2 OF 7
 INDEX WORK ORDER: 185.005

INDEXED 7-19-04 4-1

840

840

830

830

820

820

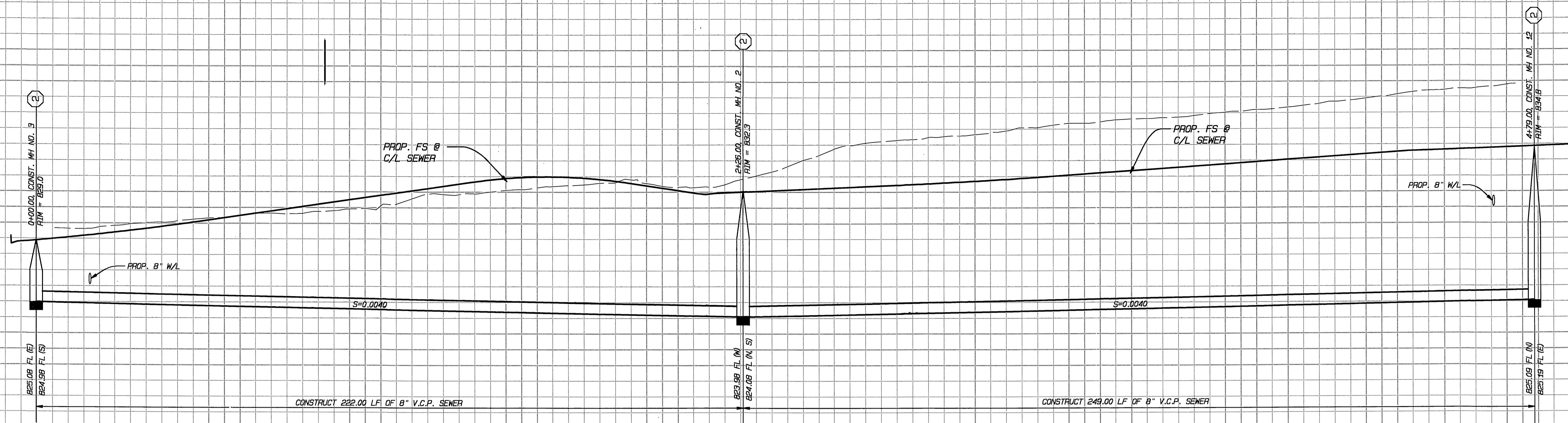

PROFILE SCALES	
HORIZONTAL	1" = 20'
VERTICAL	1" = 4'

MAYWOOD WY.
SEE SHEET 4

WILLOWGROVE PL.
SEE SHEET 6

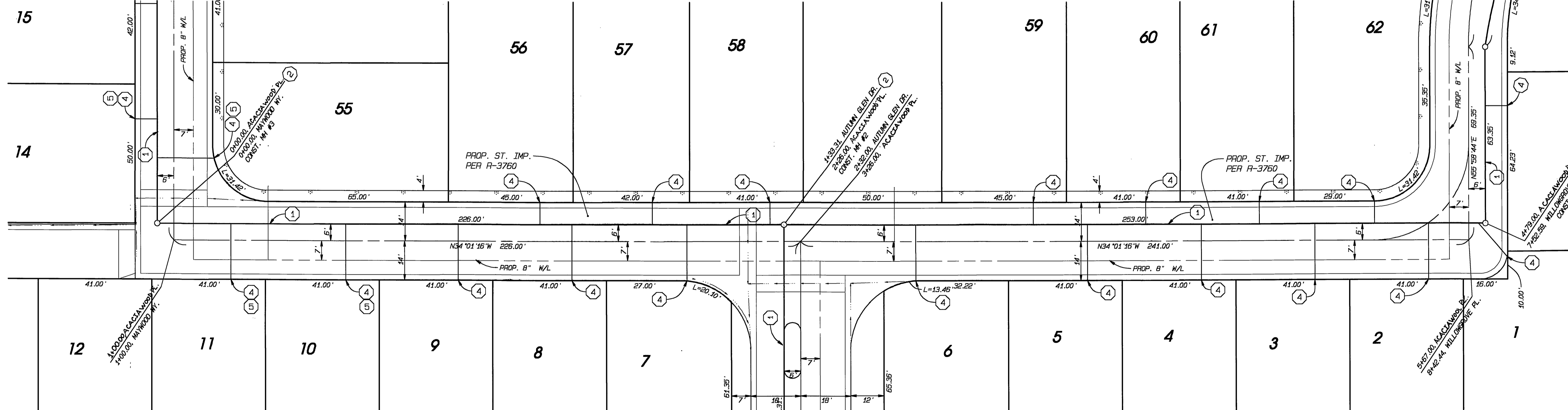

AUTUMN GLEN DR.
SEE SHEET 2

ACACIAWOOD PL.

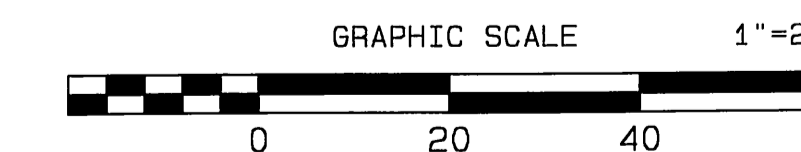

Underground Service Alert
Call: TOLL FREE
1-800-227-2600
TWO WORKING DAYS BEFORE YOU DIG

BENCHMARK
RIV. CO. B.M. F5-K3 ELEVATION = 836.398
PK NAIL W/ CITY ENGINEERS TAG IN THE NOSE OF THE CENTER MEDIAN ISLAND ALONG ADAMS ST. AT INDIANA AVE.

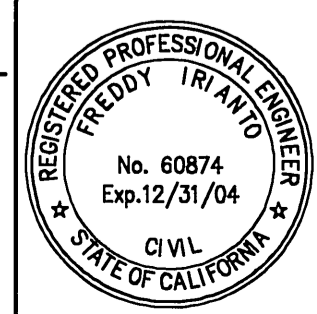

IW Consulting Engineers, Inc.
Civil Engineering
Surveying
Land Planning
3544 University Avenue Tel: 909.687.2929
Riverside, CA 92501 FAX: 909.687.2999
RIVERSIDE BUSINESS TAX CERTIFICATE #106499, EXP. 1/1/05

5/24/04

CITY OF RIVERSIDE
PUBLIC WORKS DEPARTMENT
APPROVED BY: [Signature]
PRINCIPAL ENGINEER
DATE: 6/16/04
TRAFFIC DIVISION

SEWER PLAN & PROFILE
TRACT NO. 30741
ACACIAWOOD PL.

PW 03-0378
ACCOUNT NO.
S-1829
SHEET 3 OF 7
INDEX WORK ORDER 185,009

INDEXED 7-19-04

840

840

830

830

820

820

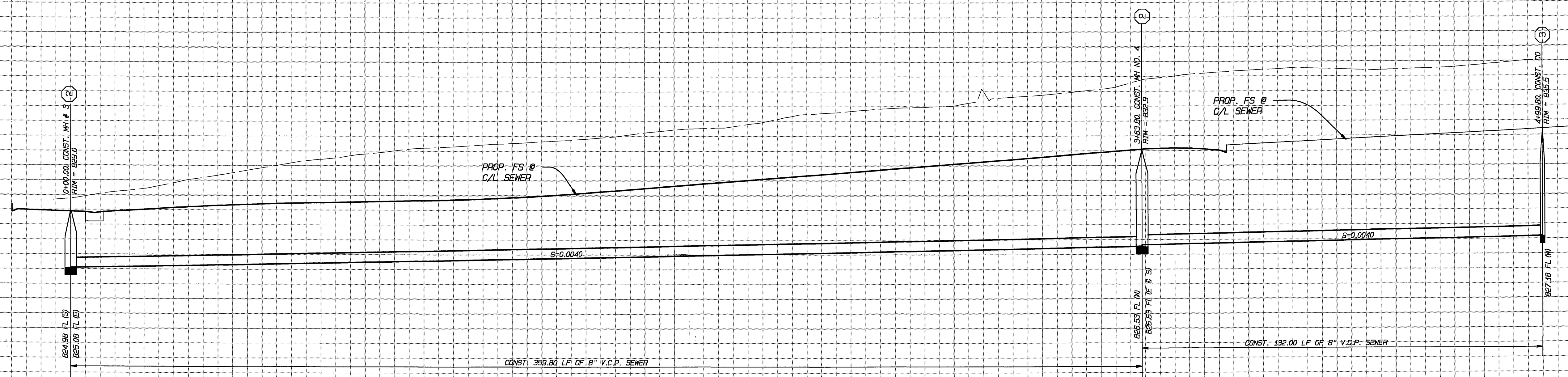

PROFILE SCALES	
HORIZONTAL	1" = 20'
VERTICAL	1" = 4'

0 1 2 3 4 5

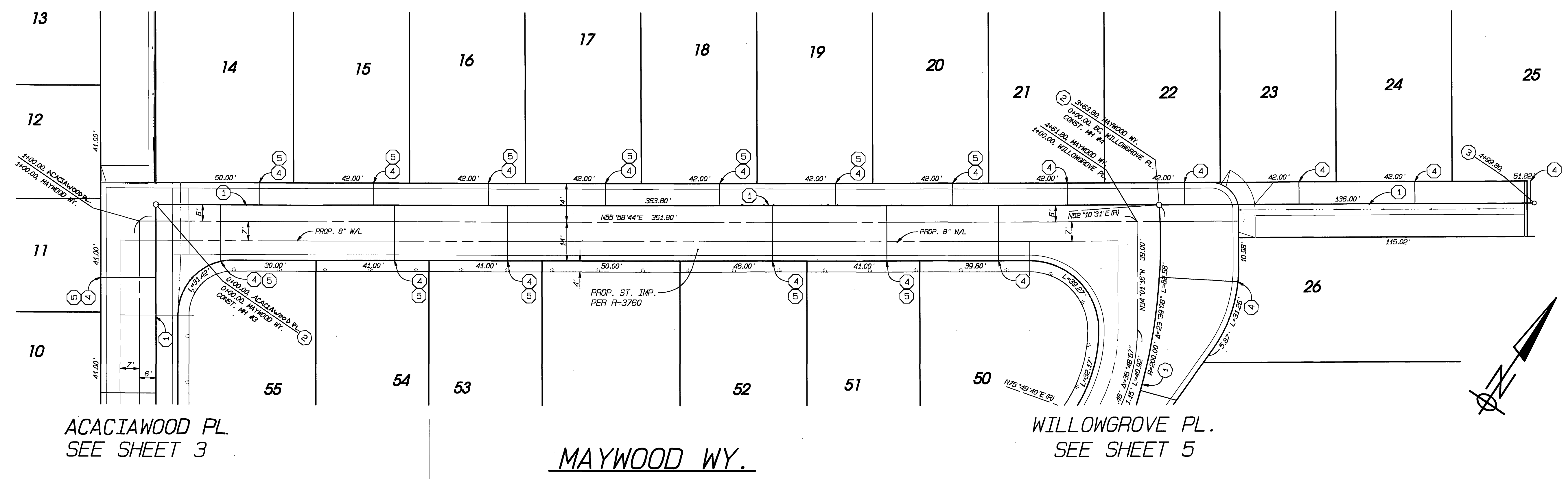

ACACIAWOOD PL.
SEE SHEET 3

MAYWOOD WY.

WILLOWGROVE PL.
SEE SHEET 5

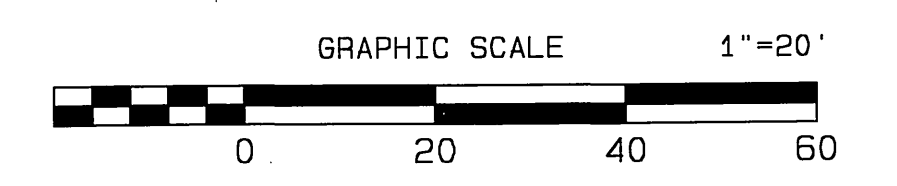
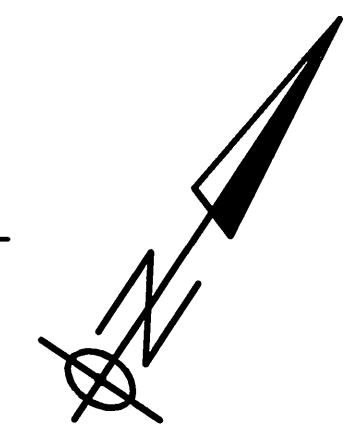

Underground Service Alert
Call: TOLL FREE
1-800-227-2600
TWO WORKING DAYS BEFORE YOU DIG

BENCHMARK
RIV. CO. B.M. FS-K3 ELEVATION = 836.398
PK NAIL W/ CITY ENGINEERS TAG IN THE NOSE OF THE CENTER MEDIAN ISLAND ALONG ADAMS ST. AT INDIANA AVE.

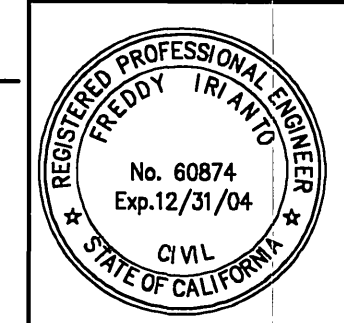

IW Consulting Engineers, Inc.
Civil Engineering
Surveying
Land Planning
3544 University Avenue
Riverside, CA 92501
Tel: 909.687.2929
Fax: 909.687.2999
RIVERSIDE BUSINESS TAX CERTIFICATE #105188, EXP. 1/1/05
APPROVED BY: FREDDY IRIANTO, P.C.E. 60874, EXP. 12/31/04 DATE: 5/24/04

REVISIONS	APPROVED	DATE	APPROVED	DATE
DESIGNED BY: _____	DRAWN BY: _____	CHECKED BY: _____	DESIGN ENG'R: _____	CITY ENG'R: _____

CITY OF RIVERSIDE
PUBLIC WORKS DEPARTMENT
APPROVED BY: _____ DATE: _____ BY: _____ APPROVED BY: _____
PRINCIPAL ENGINEER: _____ DATE: 6/16/04
TRAFFIC DIVISION: _____ CITY ENGINEER: _____

SEWER PLAN & PROFILE
TRACT NO. 30741
MAYWOOD WY.
HORIZONTAL SCALE: 1" = 20' VERTICAL SCALE: 1" = 4'

PW 03-0378
ACCOUNT NO.
S-1829
SHEET 4 OF 7
INVEST WORK ORDER: 185.005

INDEXED 7-19-04 left

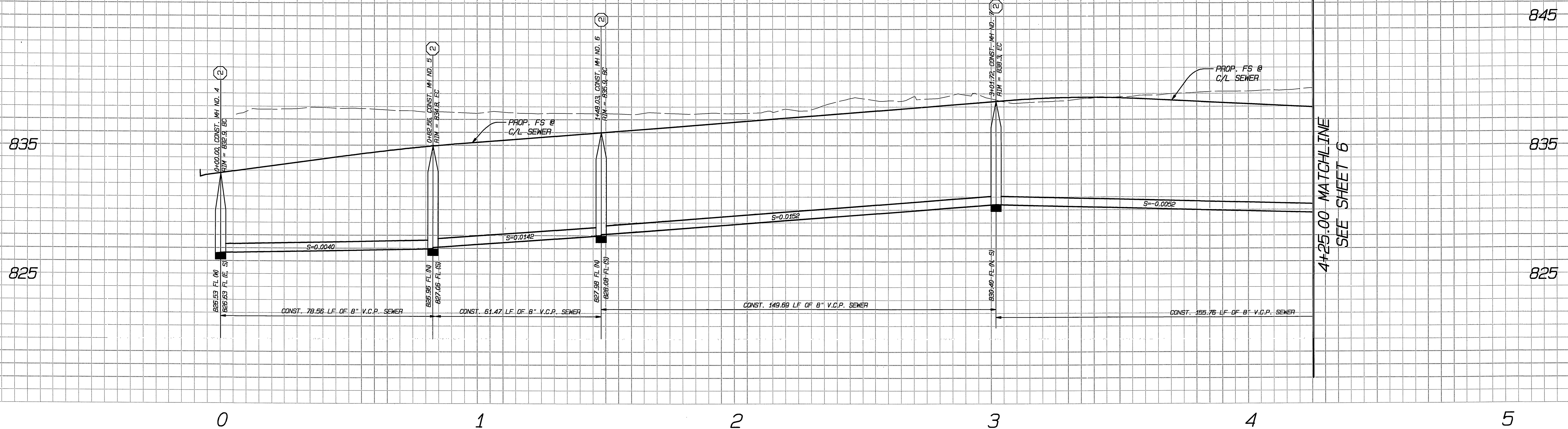

PROFILE SCALES	
HORIZONTAL	1" = 20'
VERTICAL	1" = 4'

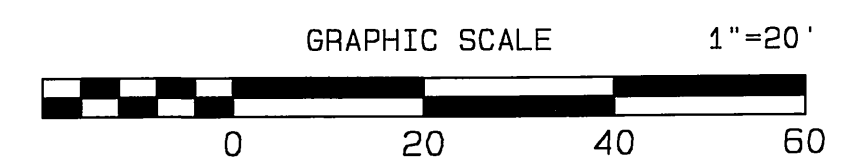
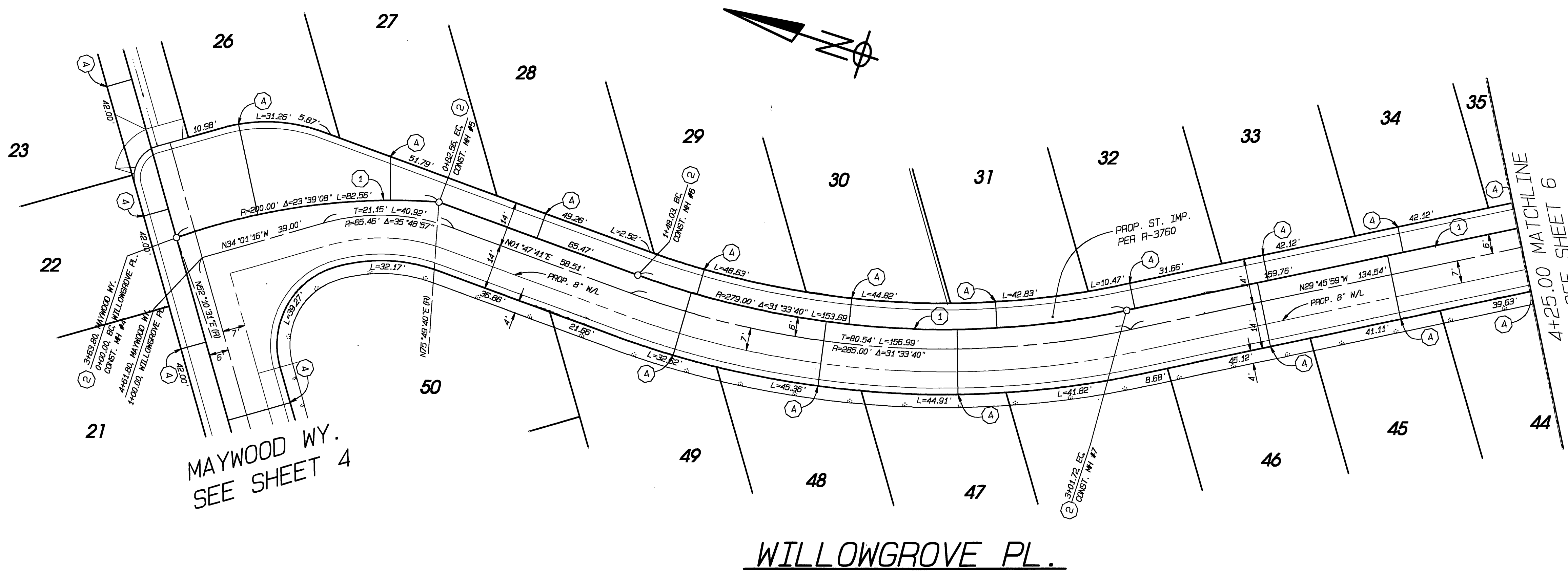

Underground Service Alert
Call: TOLL FREE
1-800-227-2600
TWO WORKING DAYS BEFORE YOU DIG

BENCHMARK
RIV. CO. B.M. F5-K3 ELEVATION = 836.398
PK NAIL W/ CITY ENGINEERS TAG IN THE NOSE OF THE CENTER MEDIAN ISLAND ALONG ADAMS ST. AT INDIANA AVE.

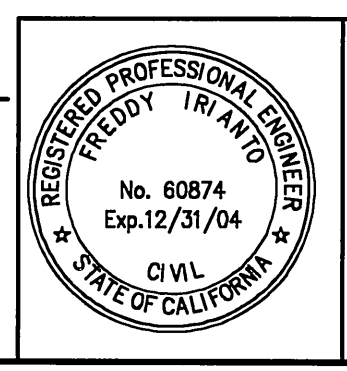

IW Consulting Engineers, Inc.
Civil Engineering
Surveying
Land Planning
3544 University Avenue
Riverside, CA 92501
Tel: 909.687.2929
Fax: 909.687.2999
RIVERSIDE BUSINESS TAX CERTIFICATE #106498, EXP. 1/1/05

APPROVED BY: <i>Freddy Irianto</i> DATE: 5/24/04	DESIGNED BY: _____	DRAWN BY: _____	CHECKED BY: _____
APPROVED DATE: _____	DESIGN ENGR.:	APPROVED DATE: _____	CITY ENGR.:

CITY OF RIVERSIDE
PUBLIC WORKS DEPARTMENT
APPROVED BY: _____ DATE: 6/16/04
PRINCIPAL ENGINEER: _____
TRAFFIC DIVISION: _____

SEWER PLAN & PROFILE
TRACT NO. 30741
WILLOWGROVE PL.
HORIZONTAL SCALE: 1" = 20' VERTICAL SCALE: 1" = 4'

PW 03-0378
ACCOUNT NO.
S-1829
SHEET 5 OF 7
INDEXED 7-19-04 lft

840

840

830

830

820

820

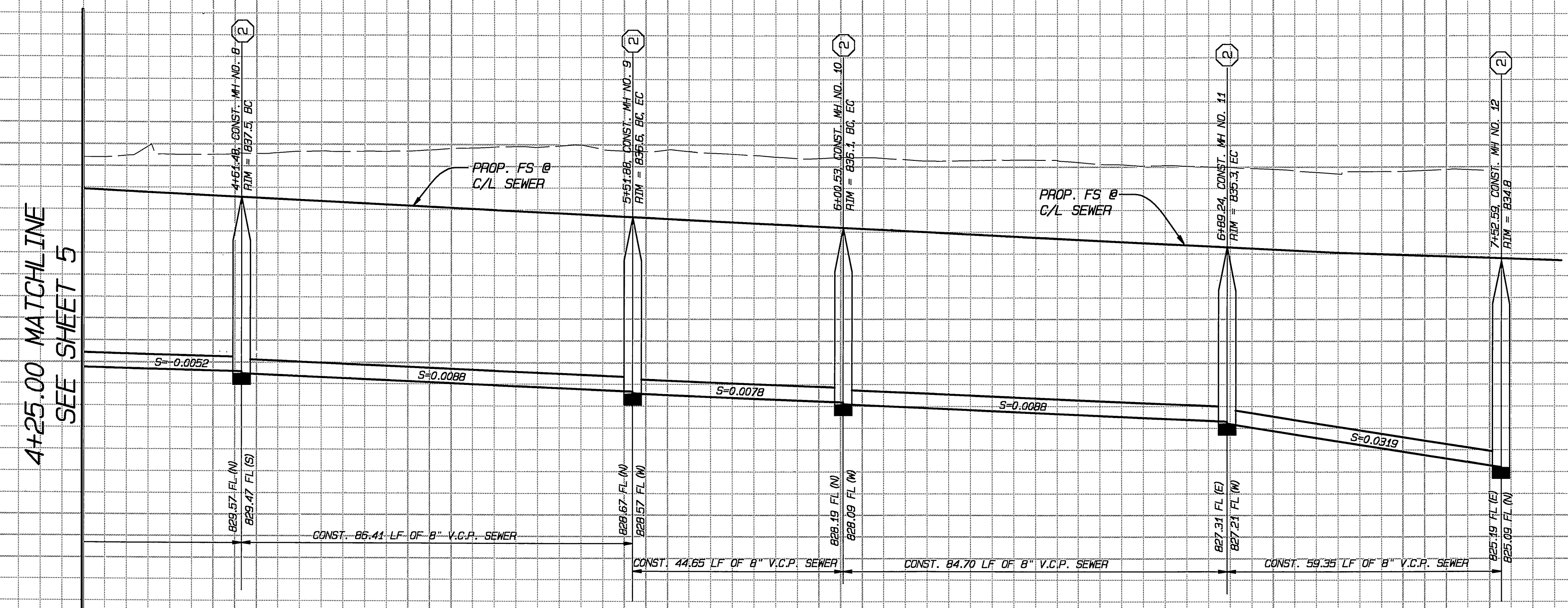

4+25.00 MATCHLINE
SEE SHEET 5

PROFILE SCALES	
HORIZONTAL	1" = 20'
VERTICAL	1" = 4'

4 5 6 7 8

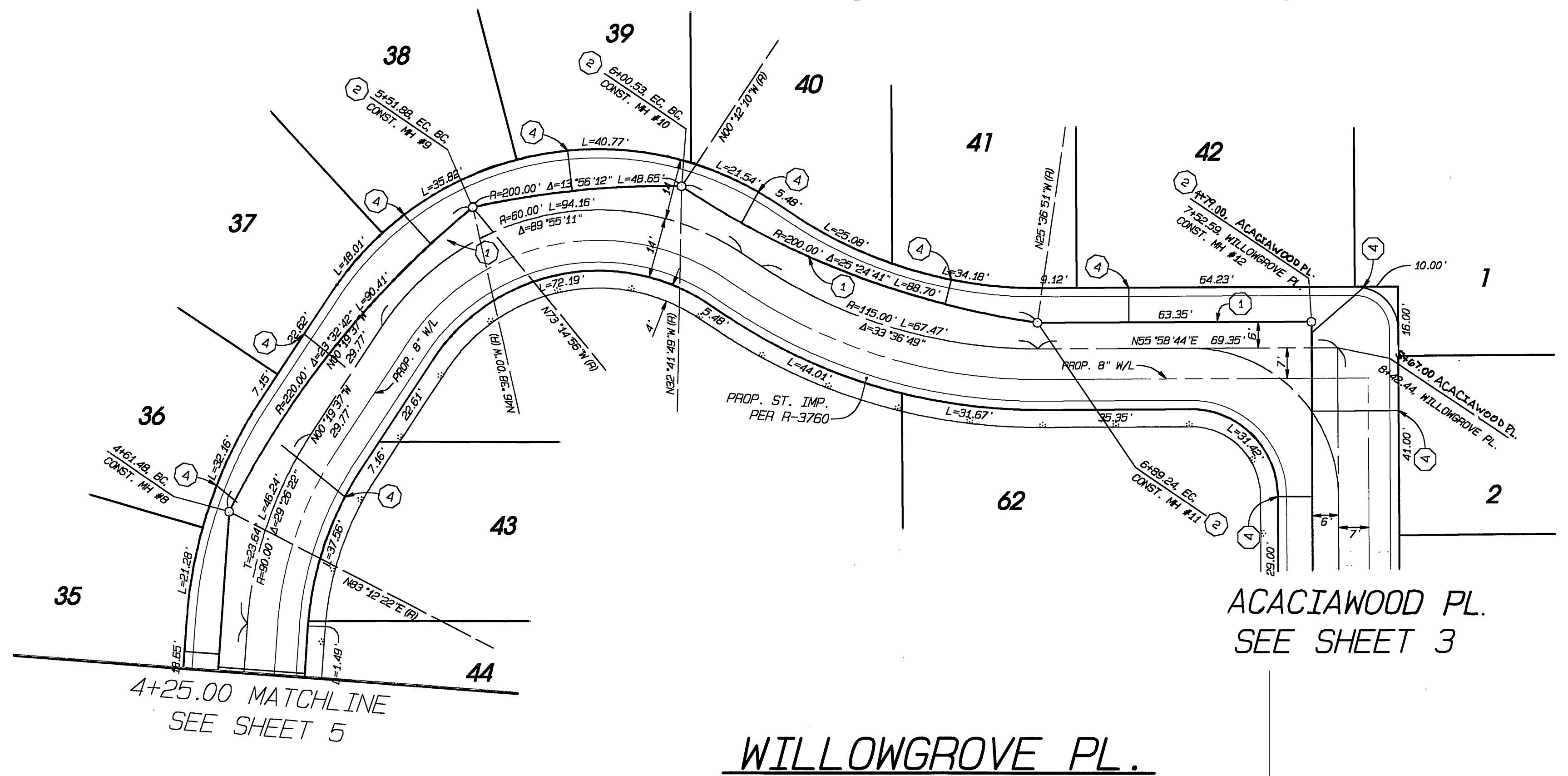

4+25.00 MATCHLINE
SEE SHEET 5

ACACIAWOOD PL.
SEE SHEET 3

WILLOWGROVE PL.

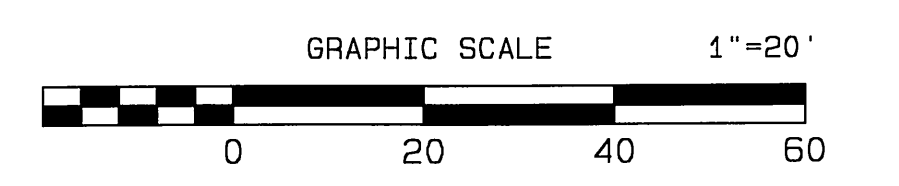
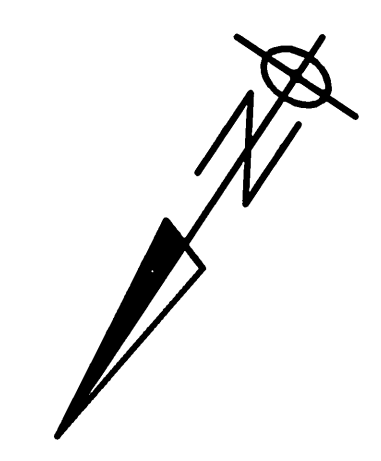

Underground Service Alert
Call: TOLL FREE
1-800
227-2600

BENCHMARK
RIV. CO. B.M. FS-K3 ELEVATION = 836.398
PK NAIL W/ CITY ENGINEERS TAG IN THE NOSE OF THE
CENTER MEDIAN ISLAND ALONG ADAMS ST. AT INDIANA AVE.

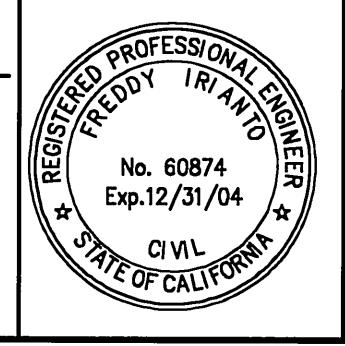

IW Consulting Engineers, Inc.
Civil Engineering
Surveying
Land Planning
3544 University Avenue
Riverside, CA 92501
Tel: 909.887.2929
Fax: 909.887.2999
RIVERSIDE BUSINESS TAX CERTIFICATE #109198, EXP. 1/1/05

APPROVED BY: *Freddy Irianto* DATE: 5/24/04

MARK	REVISIONS	APPROVED DATE	APPROVED DATE
DESIGNED BY:	DRAWN BY:	CHECKED BY:	DESIGN ENGR. CITY ENGR.

CITY OF RIVERSIDE
PUBLIC WORKS DEPARTMENT

APPROVED BY	DATE	BY	APPROVED BY
PRINCIPAL ENGINEER	4/16/04	<i>[Signature]</i>	CITY ENGINEER
TRAFFIC DIVISION			

DATE: 6/16/04

SEWER PLAN & PROFILE
TRACT NO. 30741
WILLOWGROVE PL.

PW 03-0378
ACCOUNT NO.
S-1829
SHEET 6 OF 7
INDEX WORK ORDER: 185.005

INDEXED 7-19-04

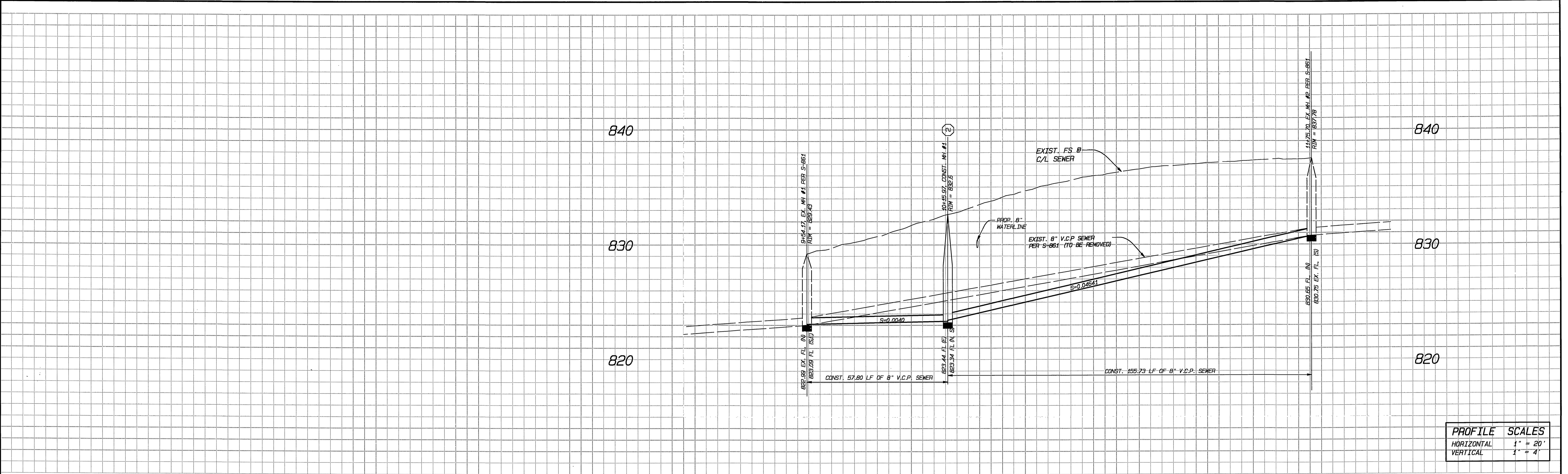

PROFILE SCALES	
HORIZONTAL	1" = 20'
VERTICAL	1" = 4'

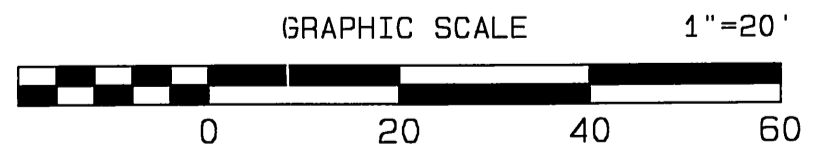
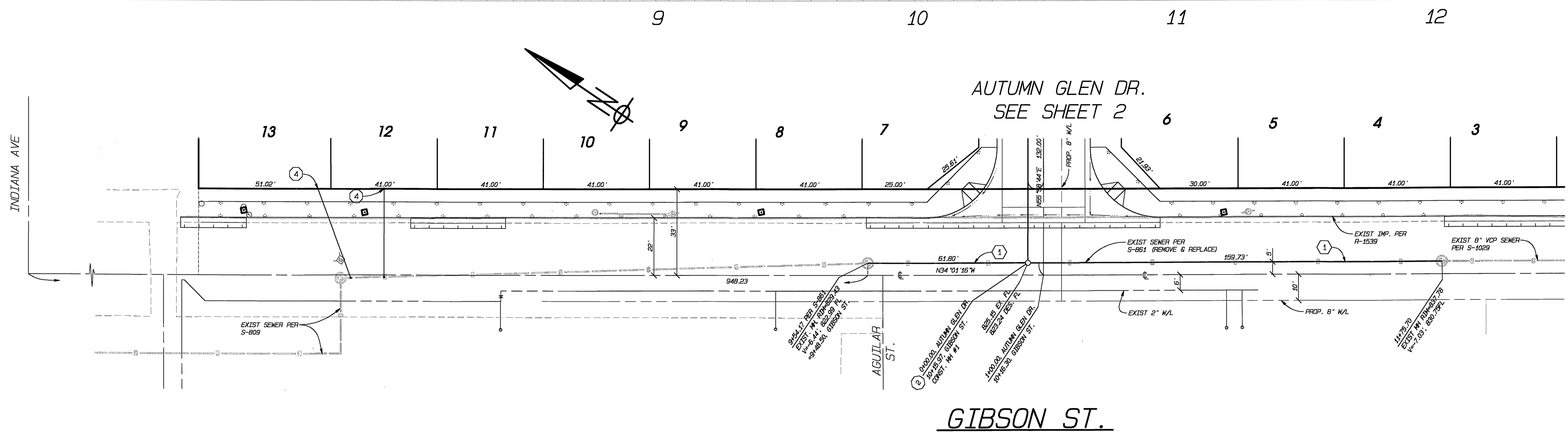

Underground Service Alert
 Call: TOLL FREE
 1-800
 227-2600
 TWO WORKING DAYS BEFORE YOU DIG

BENCHMARK
 RIV. CO. B.M. F5-K3 ELEVATION = 836.398
 PK NAIL W/ CITY ENGINEERS TAG IN THE NOSE OF THE CENTER MEDIAN ISLAND ALONG ADAMS ST. AT INDIANA AVE.

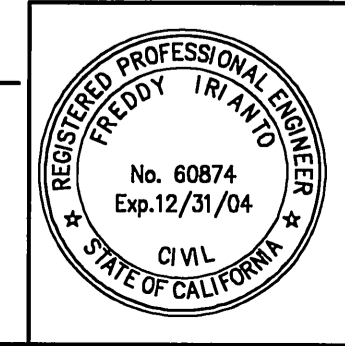

IW Consulting Engineers, Inc.
 Civil Engineering, Surveying, Land Planning
 3544 University Avenue, Riverside, CA 92501
 Tel: 909.687.2929, Fax: 909.687.2999
 APPROVED BY: FREDDY IRIANTO, RCE 60874, EXP. 12/31/04 DATE: 5/24/04

MARK	REVISIONS	APPROVED	DATE	APPROVED	DATE
DESIGNED BY:	DRAWN BY:	CHECKED BY:	DESIGN ENG'R:	CITY ENG'R:	

CITY OF RIVERSIDE
 PUBLIC WORKS DEPARTMENT
 APPROVED BY: [Signature] DATE: 6/16/04
 PRINCIPAL ENGINEER
 PARK DEPARTMENT
 TRAFFIC DIVISION
 DATE: 6-16-04

SEWER PLAN & PROFILE
 TRACT NO. 30741
GIBSON ST.
 HORIZONTAL SCALE: 1" = 20' VERTICAL SCALE: 1" = 4'

PW 03-0378
 ACCOUNT NO. S-1829
 SHEET 7 OF 7
 INDEXED 7-19-04 LFH