

GENERAL NOTES

- NO PERSON SHALL PERFORM ANY CONSTRUCTION ACTIVITY OR INSTALL ANY OBJECTS WITHIN THE PUBLIC RIGHT-OF-WAY OR EASEMENTS OF THE COUNTY OF RIVERSIDE WITHOUT A VALID CONSTRUCTION PERMIT OR, A STREET OPENING PERMIT OR AN ENCROACHMENT PERMIT ISSUED BY THE COUNTY'S PUBLIC WORKS DEPARTMENT.
- IT SHALL BE THE RESPONSIBILITY OF THE CONTRACTOR TO CLEAR THE RIGHT OF WAY IN ACCORDANCE WITH THE PROVISIONS OF LAW AS IT AFFECTS EACH UTILITY INCLUDING IRRIGATION LINES AND APPURTENANCES AND AT NO COST TO THE COUNTY.
- CONSTRUCTION SHALL BE IN ACCORDANCE WITH THE COUNTY OF RIVERSIDE DEPARTMENT OF PUBLIC WORKS, STANDARD DRAWINGS, ITS SUPPLEMENTAL NOTES AND THE STANDARD SPECIFICATIONS FOR PUBLIC WORKS CONSTRUCTION, CURRENT EDITION.
- THE PRIVATE ENGINEER SIGNING THESE PLANS IS RESPONSIBLE FOR ASSURING THE ACCURACY AND ACCEPTABILITY OF THE WORK HEREON. IN THE EVENT OF DISCREPANCIES ARISING DURING CONSTRUCTION, THE PRIVATE ENGINEER SHALL BE RESPONSIBLE FOR DETERMINING AN ACCEPTABLE SOLUTION AND REVISING THE PLANS FOR APPROVAL BY THE COUNTY.
- QUANTITIES SHOWN ARE FOR INFORMATION ONLY AND THE COUNTY OF RIVERSIDE IS NOT RESPONSIBLE FOR THEIR ACCURACY.
- THE DEVELOPER SHALL BE RESPONSIBLE FOR PRESERVING OR RE-ESTABLISHING AND REFERENCING SURVEY MONUMENTS DESTROYED, DISTURBED OR BURIED AS A RESULT OF CONSTRUCTION SHOWN HEREON.
- ALL FLAGGED ELEVATIONS SHALL BE STAKED IN THE FIELD BY THE PRIVATE ENGINEER.
- ANY TRAFFIC CONTROL STRIPING OBLITERATED AND/OR BADLY WORN DURING CONSTRUCTION SHALL BE RESTORED BY THE CONTRACTOR WITHIN FIVE DAYS AFTER NOTIFICATION FROM THE COUNTY INSPECTORS.
- THE CONTRACTOR SHALL CALL IN A LOCATION REQUEST TO UNDERGROUND SERVICE ALERT (USA), PHONE #1-800-227-2600, TWO WORKING DAYS BEFORE DIGGING. NO CONSTRUCTION PERMIT WILL BE ISSUED BY THE PUBLIC WORKS DEPARTMENT INVOLVING EXCAVATION FOR UNDERGROUND FACILITIES UNLESS THE APPLICANT HAS BEEN PROVIDED AN INQUIRY IDENTIFICATION NUMBER BY U.S.A.
- CONTRACTOR IS TO VERIFY EXISTING SEWER ELEVATION PRIOR TO CONSTRUCTION.
- NO FINISHED FLOOR ELEVATION SHALL BE LESS THAN 6" ABOVE THE UPPER MANHOLE RIM ELEVATION OF THE SEWER LINE SEGMENT BEING CONNECTED TO, WITHOUT HAVING A PROPER BACKWATER VALVE INSTALLED IN THE LATERAL.
- A PLUG SHALL BE INSTALLED AND WILL REMAIN IN PLACE WHERE THE NEW SEWER CONNECTS WITH THE EXISTING SEWER UNTIL THE NEW SEWER IS ACCEPTED BY THE COUNTY.
- THE SEWER CONTRACTOR SHALL ADJUST MANHOLES TO FINAL GRADE AFTER PAVING IS COMPLETED.
- ALL MATERIALS USED AND INSTALLATION SHALL CONFORM TO RIVERSIDE COUNTY STANDARDS & SPECIFICATIONS ORDINANCE 461.
- SEPARATION REQUIREMENTS BETWEEN WATER AND SEWER LINES SHALL CONFORM TO STATE HEALTH CODE STANDARDS.
- SEWER LATERALS SHALL BE INSTALLED ACCORDING TO COUNTY STANDARDS NO. 600 & 601 OR THE SERVING AGENCY.

NOTICE TO CONTRACTOR

ACCORDING TO THE INFORMATION PROVIDED BY UNDERGROUND SERVICE ALERT (U.S.A.) DATED FEBRUARY 18, 1999, THE FOLLOWING ORGANIZATIONS ARE U.S.A. MEMBERS WITHIN THE PROJECT AREA:

- ADELPHIA
- PACIFIC BELL
- RIVERSIDE HIGHLAND WATER COMPANY
- D.W.R.
- THE GAS COMPANY
- SOUTHERN CALIFORNIA EDISON

THE EXISTENCE AND LOCATIONS OF ALL UNDERGROUND UTILITIES (UTILITY PIPES, STRUCTURES, ETC.) SHOWN ON THESE PLANS (MAIN LINES ONLY - NO SERVICE LATERALS) WERE ASCERTAINED BY A REVIEW OF RECORDS PROVIDED BY THESE MEMBERS AGENCIES AND ARE APPROXIMATE. NEITHER THE OWNER NOR THE ENGINEER ASSUMES ANY RESPONSIBILITY FOR UTILITIES NOT SHOWN OR NOT IN THE LOCATION SHOWN.

THE CONTRACTOR IS REQUIRED TO TAKE DUE PRECAUTIONARY MEASURES TO PROTECT ALL UTILITIES SHOWN ON THESE PLANS AND/OR ANY OTHER UNDERGROUND UTILITIES NOT OF RECORD OR NOT SHOWN ON THESE PLANS.

UNAUTHORIZED CHANGES & USES

CAUTION: THE ENGINEER PREPARING THESE PLANS WILL NOT BE RESPONSIBLE FOR, OR LIABLE FOR, UNAUTHORIZED CHANGES TO OR USES OF THESE PLANS. ALL CHANGES TO THE PLANS MUST BE IN WRITING AND MUST BE APPROVED BY THE PREPARER OF THESE PLANS.

UNDERGROUND STRUCTURES

ALL UNDERGROUND UTILITIES OR STRUCTURES REPORTED BY THE OWNER OR OTHERS AND THOSE SHOWN ON THE RECORD EXAMINED ARE INDICATED WITH THEIR APPROXIMATE LOCATION AND EXTENT. THE OWNER BY ACCEPTING THESE PLANS OR PROCEEDING WITH IMPROVEMENTS PURSUANT THERETO AGREES TO ASSUME LIABILITY AND TO HOLD UNDERSIGNED HARMLESS FOR ANY DAMAGES RESULTING FROM THE EXISTENCE OF UNDERGROUND UTILITIES OR STRUCTURES NOT REPORTED TO THE UNDERSIGNED; NOT INDICATED ON THE PUBLIC RECORDS EXAMINED, LOCATED AT VARIANCE WITH THAT REPORTED OR SHOWN ON RECORDS EXAMINED. THE CONTRACTOR IS REQUIRED TO TAKE DUE PRECAUTIONARY MEASURES TO PROTECT THE UTILITIES OR STRUCTURES SHOWN AND ANY OTHER UTILITIES OR STRUCTURES FOUND AT THE SITE. IT SHALL BE THE CONTRACTOR'S RESPONSIBILITY TO NOTIFY THE OWNERS OF THE UTILITIES OR STRUCTURES CONCERNED BEFORE STARTING WORK.

IN THE UNINCORPORATED TERRITORY OF THE COUNTY OF RIVERSIDE, STATE OF CALIFORNIA

SEWER IMPROVEMENT PLANS

TRACT NO. 29597-1

WORK TO BE DONE

IMPROVEMENTS CONSIST OF THE FOLLOWING WORK TO BE DONE ACCORDING TO THESE PLANS, THE CURRENT RIVERSIDE COUNTY DEPARTMENT OF PUBLIC WORKS DESIGN STANDARDS AND THE CURRENT AMERICAN PUBLIC WORKS ASSOCIATION (APWA) "GREEN BOOK" STANDARDS AND SPECIFICATIONS.

CONSTRUCTION NOTES AND QUANTITY TABLE

ITEM	DESCRIPTION	AMOUNT	UNIT
1	INSTALL 8" SDR 35 PVC SEWER MAIN. BEDDING PER CITY OF RIVERSIDE STD. DWG. NO. 452	3,491	LF
2	CONSTRUCT SANITARY SEWER MANHOLE PER CITY OF RIVERSIDE STD. DWG. NO. 500	15	EA
3	INSTALL 4" PVC (SDR 35) SEWER LATERAL W/ CLEANOUT PER CITY OF RIVERSIDE STD. DWG. NO. 562A, 560	109	EA
4	REMOVE 8" PLUG	3,639	LF
5	BACKWATER VALVE	2	EA
6	SEWER MAIN CLEANOUT	40	EA
7	CAUTION! UTILITY CROSSING, SEE PROFILE FOR ELEVATIONS	0	EA
8		14	EA

ABBREVIATIONS

- ST. - STREET
- N.T.S. - NOT TO SCALE
- R/W - RIGHT OF WAY
- P/L - PROPERTY LINE
- STD. - STANDARD
- SS - SEWER SYSTEM
- MH - MANHOLE
- EX. - EXISTING
- SWR. - SEWER
- BC - BEGIN CURVE
- EC - END CURVE
- S.D. - STORM DRAIN
- I.E. - INVERT ELEVATION
- NGVD - NATIONAL GEODETIC VERTICAL DATUM
- PVC - POLYVINYL CHLORIDE
- SDR - STANDARD DIMENTION RATIO

LEGEND

- SEWER LATERAL WITH CLEANOUT
- WATER LATERAL
- FIRE HYDRANT
- EXISTING SS LINE
- EXISTING SS MANHOLE
- PROPOSED SS LINE
- PROPOSED SS MANHOLE
- TRACT BOUNDARY

OWNER / PERMITTEE

SMR VENTURES
2710 LOKER AVENUE WEST, SUITE 350
CARLSBAD, CA 92008
(760) 918-6797

BY:

ROBERT J. TURI DATE
VICE PRESIDENT

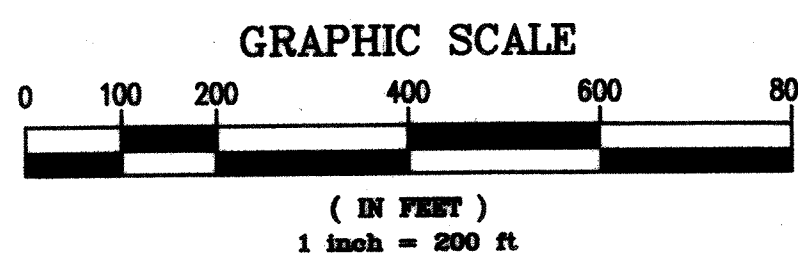
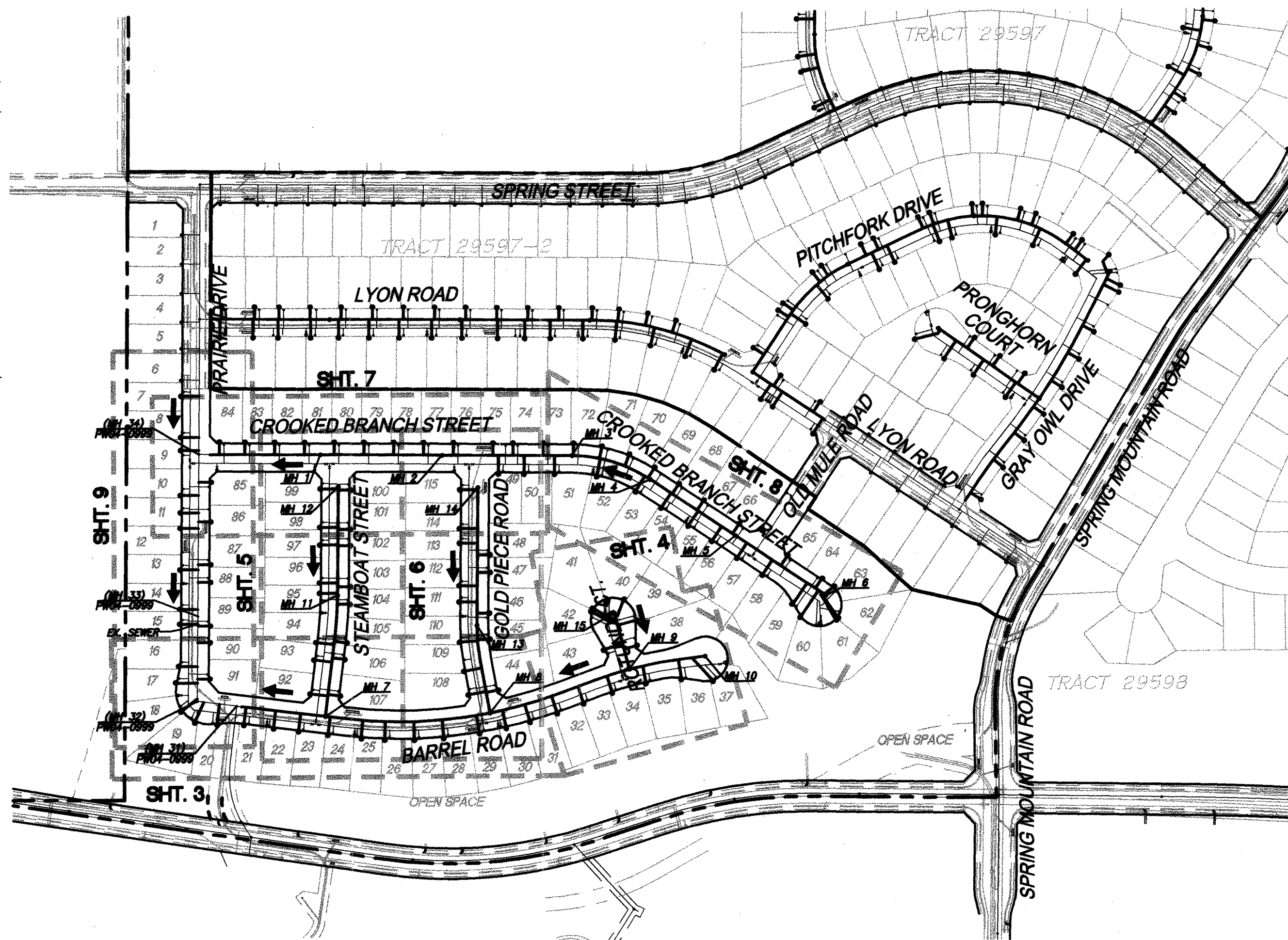

NOTE

CSA 152C SANITARY SERVICE IN THE HIGHROVE COMMUNITY FOR SPRING MOUNTAIN RANCH PROJECT PROVIDED PER THE WASTEWATER TREATMENT AGREEMENT, OPERATION AND MAINTENANCE AGREEMENT AND PRETREATMENT PROGRAM AGREEMENT BETWEEN THE COUNTY OF RIVERSIDE AND THE CITY OF RIVERSIDE. REFERENCE AGENDA ITEM NO. 3.47 OF THE COUNTY OF RIVERSIDE ECONOMIC DEVELOPMENT AGENCY, DATED MAY 4, 2004.

SCHOOL DISTRICT

RIVERSIDE UNIFIED SCHOOL DISTRICT
951-788-7134

UTILITY CONTACTS

- WATER: RIVERSIDE HIGHLAND WATER COMPANY (909) 825-4128
- SEWER: CITY OF RIVERSIDE (951) 826-5341
- CSA 152 SEE COUNTY
- ELECTRIC: SOUTHERN CALIFORNIA EDISON COMPANY, BOB SIEGAL (909) 307-6770
- TRANSMISSION, JEANETTE RIVERA (909) 930-8580
- GAS: SOUTHERN CALIFORNIA GAS COMPANY, HECTOR MARTINEZ (909) 335-7674
- TELEPHONE: PACIFIC BELL/SBC, LEE CORBY (714) 666-5454
- CABLE TV: ADELPHIA COMMUNICATIONS, MIKE McMILLAN (909) 975-3402
- DEPARTMENT OF WATER RESOURCES (661) 858-5500
- RIVERSIDE COUNTY TRANSPORTATION AND LAND MANAGEMENT AGENCY (951) 955-6740
- RIVERSIDE COUNTY FIRE DEPARTMENT (951) 955-4777

ASSESSOR'S PARCEL NO.

- 255-210-010-0, 255-170-010-7, 255-190-004-4,
- 255-180-014-2, 255-210-011-1, 255-190-005-5,
- 255-190-007-7, 255-180-010-8, 255-180-012-0,
- 255-180-016-4, 255-220-007-9, 255-240-008-2,
- 255-240-009-3, 255-230-003-6, 255-230-009-2,
- 255-240-010-3, 255-200-012-1, 255-200-009-9,
- 255-200-010-9, 257-180-008-1, 257-170-007-9,
- 255-210-012-2, 255-230-011-3, 255-230-001-4,
- 255-200-002-2, 255-200-003-3, 255-140-019-3,
- 257-100-011-5, 255-200-011-0, 255-200-014-3,
- 255-200-002-2, 255-200-013-2, 255-120-011-3,
- 257-180-009-2, 255-210-010-0, 255-210-011-1,
- 257-120-003-0, 255-200-016-5, 255-200-017-6,
- 255-210-011-1

SOURCE OF TOPOGRAPHY

TOPOGRAPHY SHOWN ON THESE PLANS WAS GENERATED BY PHOTOGRAMMETRIC METHODS FROM INFORMATION GATHERED IN DECEMBER OF 2003, BY INLAND AERIAL SURVEYS, INC. TOPOGRAPHY SHOWN HEREON CONFORMS TO NATIONAL MAP ACCURACY STANDARDS.

LEGAL DESCRIPTION

BEING A DIVISION OF PORTIONS OF SECTIONS 8, 9, AND 10, TOWNSHIP 2S, RANGE 4W, SAN BERNARDINO MERIDIAN.

DECLARATION OF RESPONSIBLE CHARGE

I HEREBY DECLARE THAT I AM THE ENGINEER OF WORK FOR THIS PROJECT, THAT I HAVE EXERCISED RESPONSIBLE CHARGE OVER THE DESIGN OF THE PROJECT AS DEFINED IN SECTION 6703 OF THE BUSINESS AND PROFESSIONAL CODE, AND THAT THE DESIGN IS CONSISTENT WITH CURRENT STANDARDS. IN ASSUMING RESPONSIBLE CHARGE I ACCEPT FULL RESPONSIBILITY FOR THE ENTIRE DESIGN OF THIS PROJECT AS SHOWN ON THESE PLANS.

I UNDERSTAND THAT THE CHECK OF PROJECT DRAWINGS AND SPECIFICATIONS BY THE COUNTY OF RIVERSIDE, CITY OF RIVERSIDE, OR THEIR AGENTS IS CONFINED TO A REVIEW ONLY AND DOES NOT RELIEVE ME, AS ENGINEER OF WORK, OF MY RESPONSIBILITIES FOR THE PROJECT DESIGN.

STANTEC CONSULTING INC.
277 RANCHEROS DRIVE, SUITE 300
SAN MARCOS, CA 92069
P: (760) 891-3200
F: (760) 891-3201

KENT J. STEPAN R.C.E. C 66133 DATE
EXPIRATION DATE: 06-30-06



CITY OF RIVERSIDE
RECOMMENDS APPROVAL

Kent J. Stephan 10/27/06
CITY ENGINEER DATE

Thomas Guide (2004); page. 646, E-7

VICINITY MAP

NOT TO SCALE
SECTION: 9, 10, 15, AND 16
TOWNSHIP: 2 SOUTH, RANGE: 4 WEST
SBM

SHEET INDEX

- TITLE AND INDEX MAP SHEET ----- 1
- CONSTRUCTION NOTES AND DETAILS ----- 2
- BARREL ROAD ----- 3 - 4
- ROTUNDA COURT ----- 4
- STEAMBOAT STREET ----- 5
- GOLD PIECE ROAD ----- 6
- CROOKED BRANCH STREET ----- 7 - 8
- PRAIRIE DRIVE ----- 9



COUNTY OF RIVERSIDE
DEPARTMENT OF HEALTH
APPROVED BY: _____
DATE: _____

NOTE: WORK CONTAINED WITHIN THESE PLANS SHALL NOT COMMENCE UNTIL AN ENCROACHMENT PERMIT AND/OR GRADING PERMIT HAS BEEN ISSUED.

THE PRIVATE ENGINEER SIGNING THESE PLANS IS RESPONSIBLE FOR ASSURING THE ACCURACY AND ACCEPTABILITY OF THE DESIGN HEREON. IN THE EVENT OF DISCREPANCIES AFTER COUNTY APPROVAL OR DURING CONSTRUCTION, THE PRIVATE ENGINEER SHALL BE RESPONSIBLE FOR DETERMINING AN ACCEPTABLE SOLUTION AND REVISING THE PLANS FOR APPROVAL BY THE COUNTY.

DATE	BY	MARK	REVISIONS	APPR.	DATE

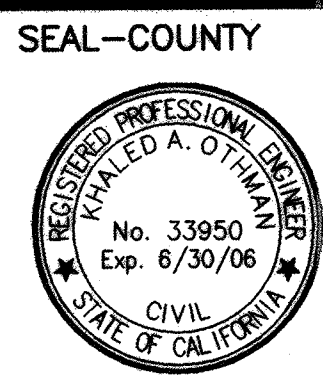

SEAL-COUNTY
COUNTY OF RIVERSIDE
TRANSPORTATION DEPARTMENT
APPROVED BY:
KHALED A. OTHMAN DATE: _____
RECOMMENDED DATE: _____

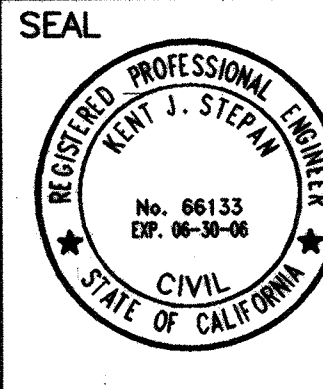

SEAL
STANTEC CONSULTING INC.
277 RANCHEROS DRIVE
SUITE 300
SAN MARCOS, CA 92069
760.891.3200
PREPARED BY: *Kent J. Stephan* R.C.E. NO. 66133 DATE: 10/27/06
KENT J. STEPAN

BENCHMARK DATUM - NAVD 88
PROJECT BENCHMARK
CITY OF RIVERSIDE B.M. JB-D3
ELEVATION: 918.908 (NGVD29) PUBLISHED/921.398 ADJUSTED TO NAVD88 (ADD 2.49' PER NGS VERTCON PROGRAM=921.398 NAVD88)
DESCRIPTION: LEAD & TACK IN TOP OF CURB 3.5' N/O BCR OF NW CURB RETURN AT PALMYRITA AVE. & IOWA AVE.
BASIS OF BEARINGS
BEARINGS SHOWN HEREON ARE GRID BEARINGS PER THE CALIFORNIA COORDINATE SYSTEM ZONE 8.
SCALE:
HOR: N/A VERT: N/A

CITY OF RIVERSIDE DRAWING NO. S-1899
WDID No. 833C327881 PW05-0223

TRACT NO. 29597-1 IP NO. 050026
COUNTY OF RIVERSIDE
SEWER IMPROVEMENT PLANS
SPRING MOUNTAIN RANCH
TITLE AND INDEX
MAP SHEET
SHEET NO. 1
OF 9 SHEETS
FOR: W.O. COUNTY FILE NO.

INDEXED 5-02-07

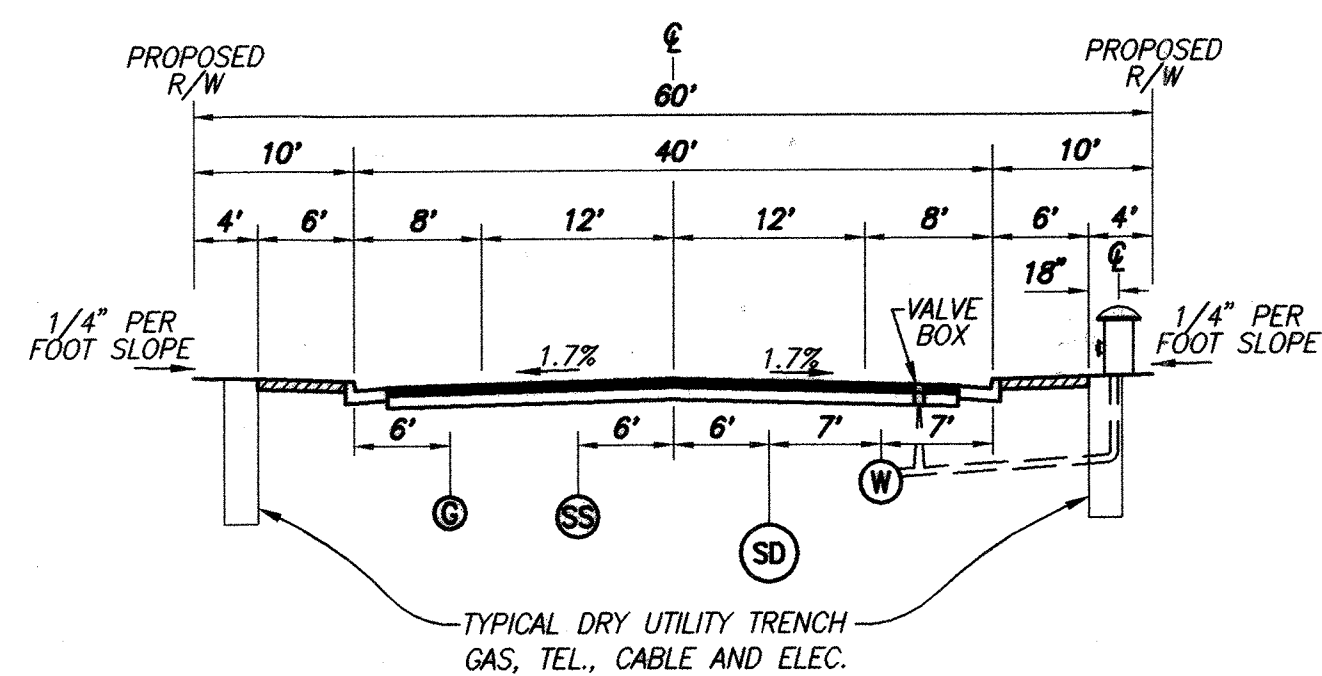

TYPICAL SECTION
 BARREL ROAD STA: 21+01.61 TO STA: 27+88.09
 GOLD PIECE DRIVE STA: 9+97.47 TO STA: 15+80.67
 PRAIRIE DRIVE STA: 17+29.69 TO STA: 21+01.61
 NTS

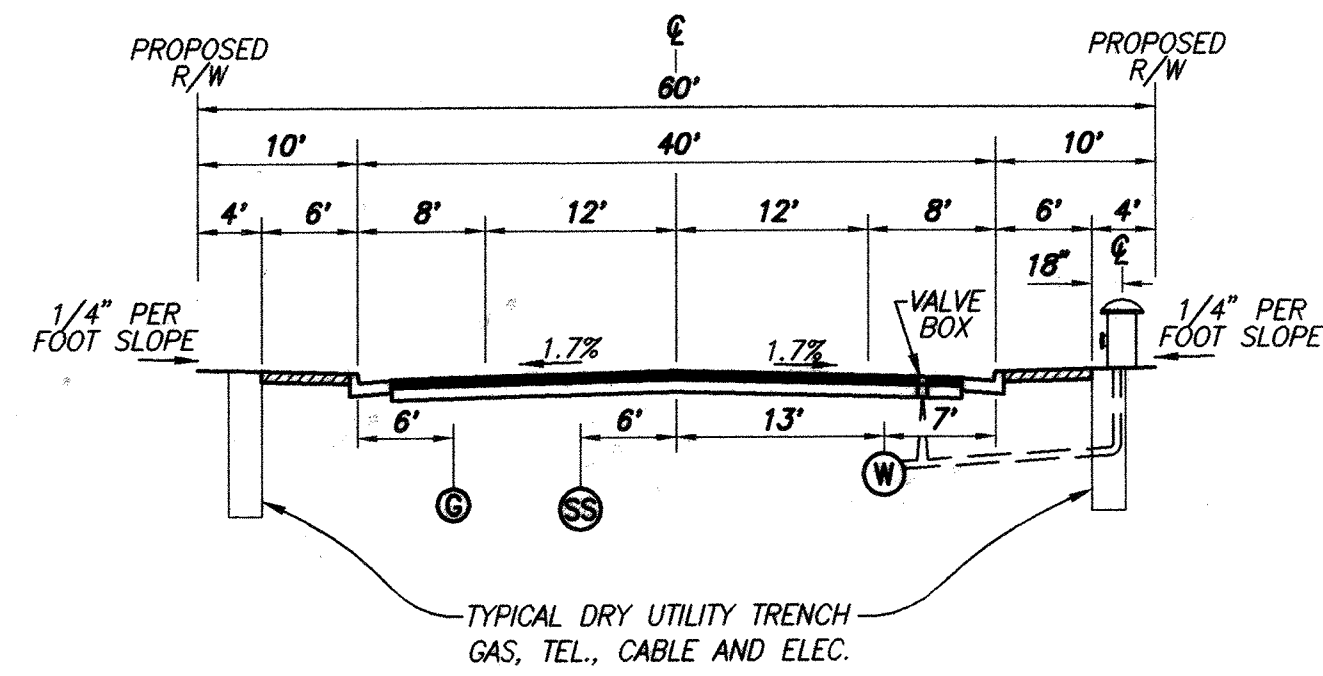

TYPICAL SECTION
 BARREL ROAD STA: 27+88.09 TO STA: 32+11.35
 CROOKED BRANCH STREET STA: 9+87.00 TO STA: 24+58.01
 OLD MULE ROAD STA: 9+87.00 TO STA: 13+00.00
 PRAIRIE DRIVE STA: 14+30.77 TO STA: 17+29.69
 ROTUNDA COURT STA: 9+86.89 TO STA: 11+34.73
 STEAMBOAT STREET STA: 9+87.00 TO STA: 15+52.14
 NTS

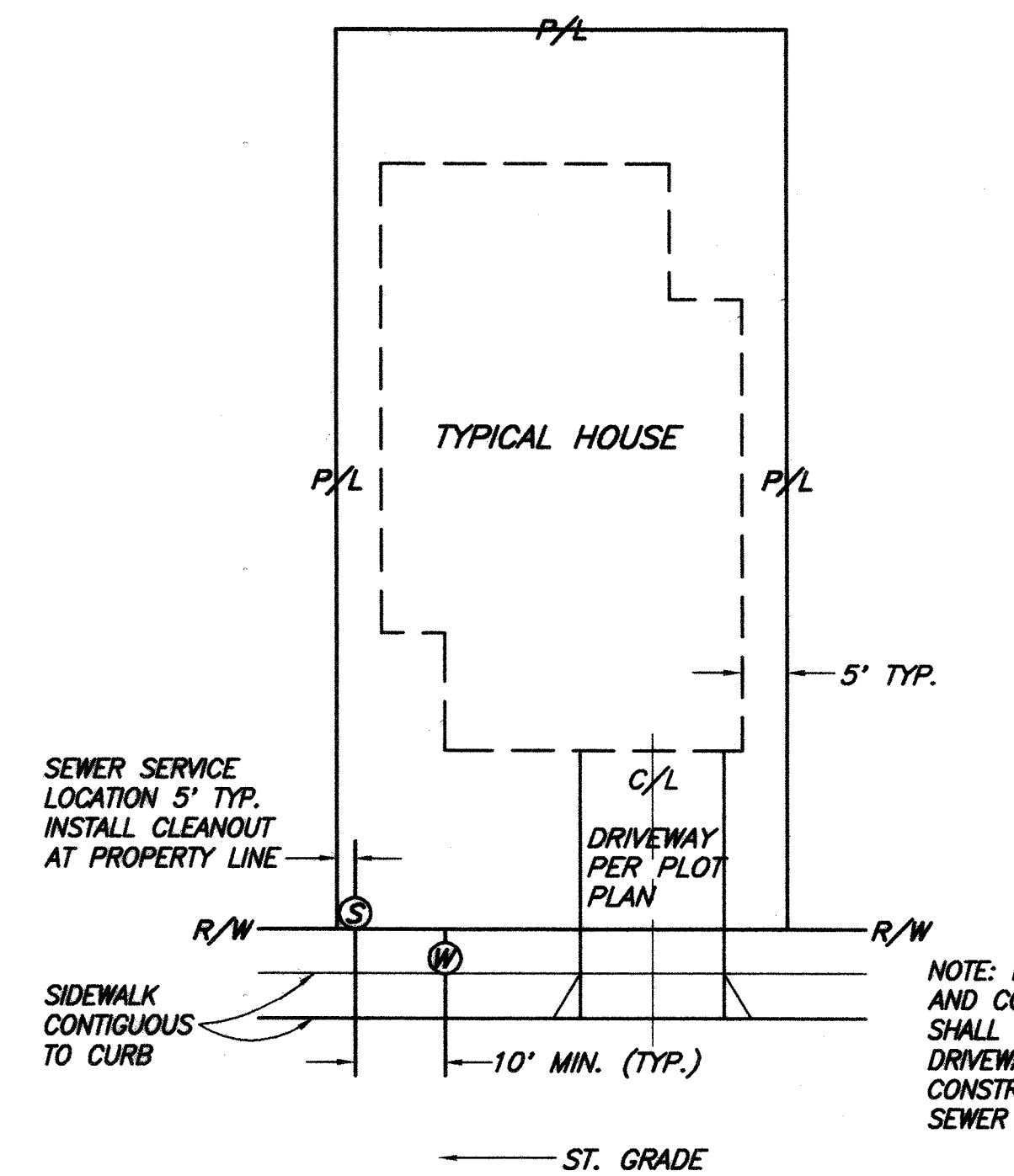

TYPICAL LATERAL LOCATION DETAIL "C"

NOTE: SEWER LATERAL SHALL BE INSTALLED BY SEPARATE PLAN

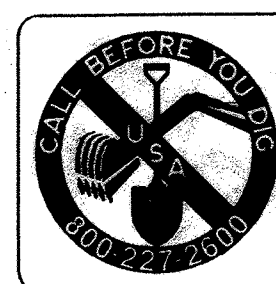

NOTE: WORK CONTAINED WITHIN THESE PLANS SHALL NOT COMMENCE UNTIL AN ENCROACHMENT PERMIT AND/OR GRADING PERMIT HAS BEEN ISSUED.

THE PRIVATE ENGINEER SIGNING THESE PLANS IS RESPONSIBLE FOR ASSURING THE ACCURACY AND ACCEPTABILITY OF THE DESIGN HEREON. IN THE EVENT OF DISCREPANCIES AFTER COUNTY APPROVAL OR DURING CONSTRUCTION, THE PRIVATE ENGINEER SHALL BE RESPONSIBLE FOR DETERMINING AN ACCEPTABLE SOLUTION AND REVISING THE PLANS FOR APPROVAL BY THE COUNTY.

DATE	BY	MARK	REVISIONS	APPR.	DATE

SEAL-COUNTY
 COUNTY OF RIVERSIDE
 TRANSPORTATION DEPARTMENT
 APPROVED BY:
 KHALED A. OTHMAN
 DATE: _____
 RECOMMENDED
 DATE: _____

SEAL
 REGISTERED PROFESSIONAL ENGINEER
 KENT J. STEPAN
 No. 66133
 Exp. 06-30-06
 CIVIL
 STATE OF CALIFORNIA
 PREPARED BY:
 KENT J. STEPAN
 R.C.E. NO. 66133
 DATE: 10/22/06

STANTEC CONSULTING INC.
 277 RANCHEROS DRIVE
 SUITE 300
 SAN MARCOS, CA 92069
 760.891.3200
 stantec.com

CITY OF RIVERSIDE
 RECOMMENDS APPROVAL
 [Signature]
 CITY ENGINEER
 DATE: 10/22/06

CITY OF RIVERSIDE DRAWING NO. S-1899
 WDD No. 833C327881 PW05-0223

TRACT NO. 29597-1 IP NO. 050026
 COUNTY OF RIVERSIDE
 SEWER IMPROVEMENT PLANS
 SPRING MOUNTAIN RANCH
 SHEET NO. 2

CONSTRUCTION NOTES AND DETAILS
 OF 9 SHTS.

SCALE: HOR: AS SHOWN VERT: AS SHOWN

FOR: W.O. COUNTY FILE NO.

INDEXED 5-02-07

K:\3062001\Cadd\Imp-plan\UNIT 1 - 29597 Sewer\29597-01-02.dwg 1/24/2006 08:59:02 MST

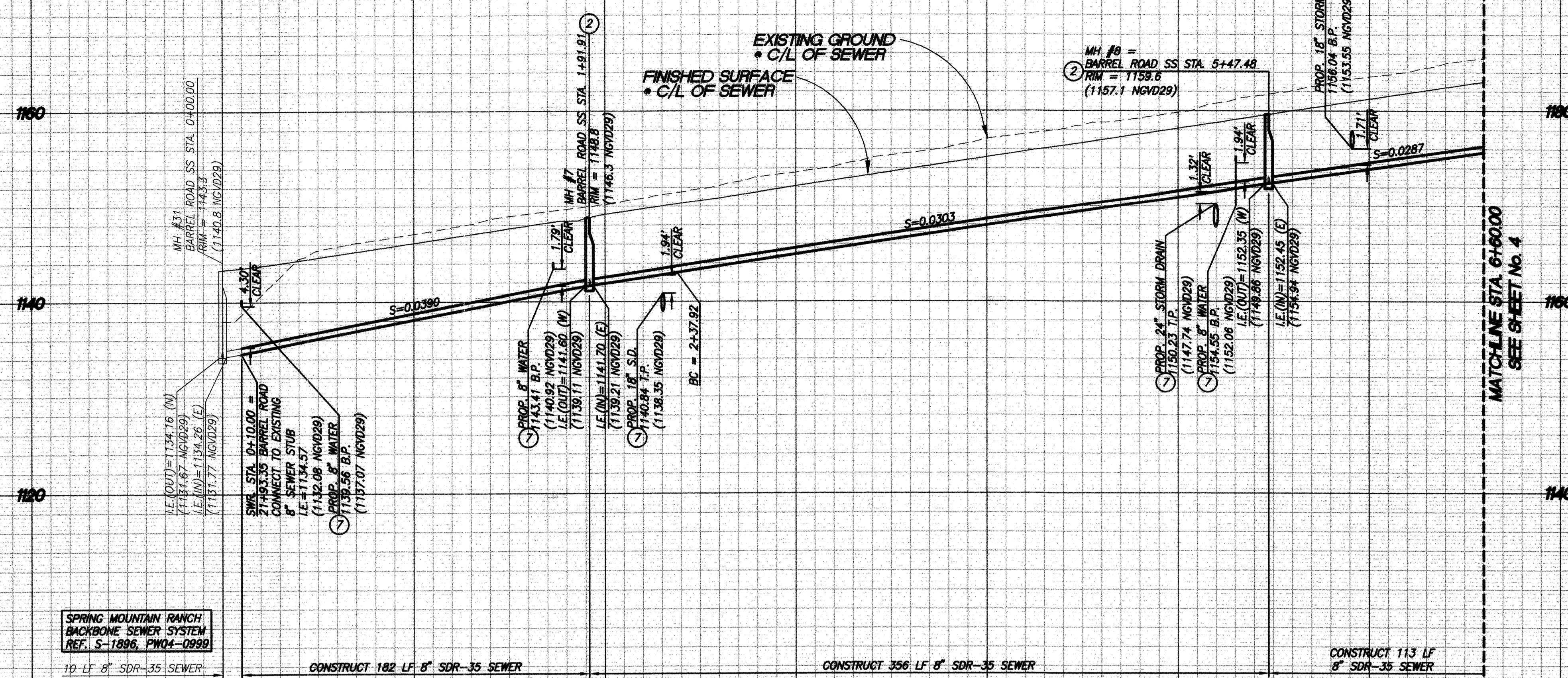

SPRING MOUNTAIN RANCH
BACKBONE SEWER SYSTEM
REF. S-1896, PW04-0899

10 LF 8" SDR-35 SEWER

CONSTRUCT 182 LF 8" SDR-35 SEWER

CONSTRUCT 356 LF 8" SDR-35 SEWER

CONSTRUCT 113 LF
8" SDR-35 SEWER

PROFILE SCALE
HORIZ: 1"=40'
VERT: 1"=8'

- NOTE:
1. ALL DATA TABLE LENGTHS ARE MEASURED TO CENTER OF MANHOLE.
 2. ALL PIPE SLOPES ARE CALCULATED FROM INSIDE MANHOLE WALL TO INSIDE MANHOLE WALL.
 3. CONTRACTOR TO VERIFY EXACT LOCATION AND DEPTH OF ALL UNDERGROUND UTILITIES PRIOR TO CONSTRUCTION.
 4. PRIOR TO THE INSTALLATION OF WATER MAINS AND FACILITIES, SEWERS AND STORM DRAINS, INCLUDING LATERALS SHALL BE INSTALLED.

CONSTRUCTION NOTES

1. INSTALL 8" SDR 35 PVC SEWER MAIN. BEDDING PER CITY OF RIVERSIDE STD. DWG. NO. 452
2. CONSTRUCT SANITARY SEWER MANHOLE PER CITY OF RIVERSIDE STD. DWG. NO. 500
3. INSTALL 4" PVC (SDR 35) SEWER LATERAL W/ CLEANOUT PER CITY OF RIVERSIDE STD. DWG. NO. 562A, 560
4. REMOVE 8" PLUG
5. BACKWATER VALVE
7. CAUTION! UTILITY CROSSING, SEE PROFILE FOR ELEVATIONS

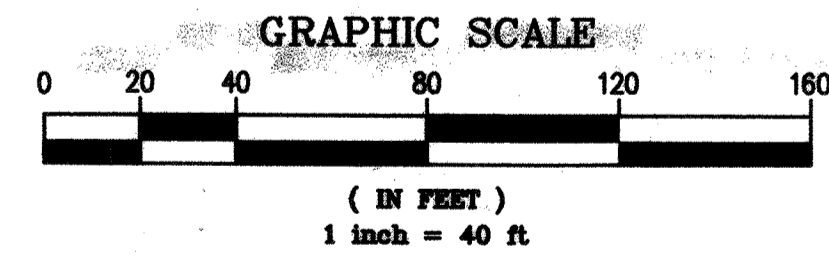
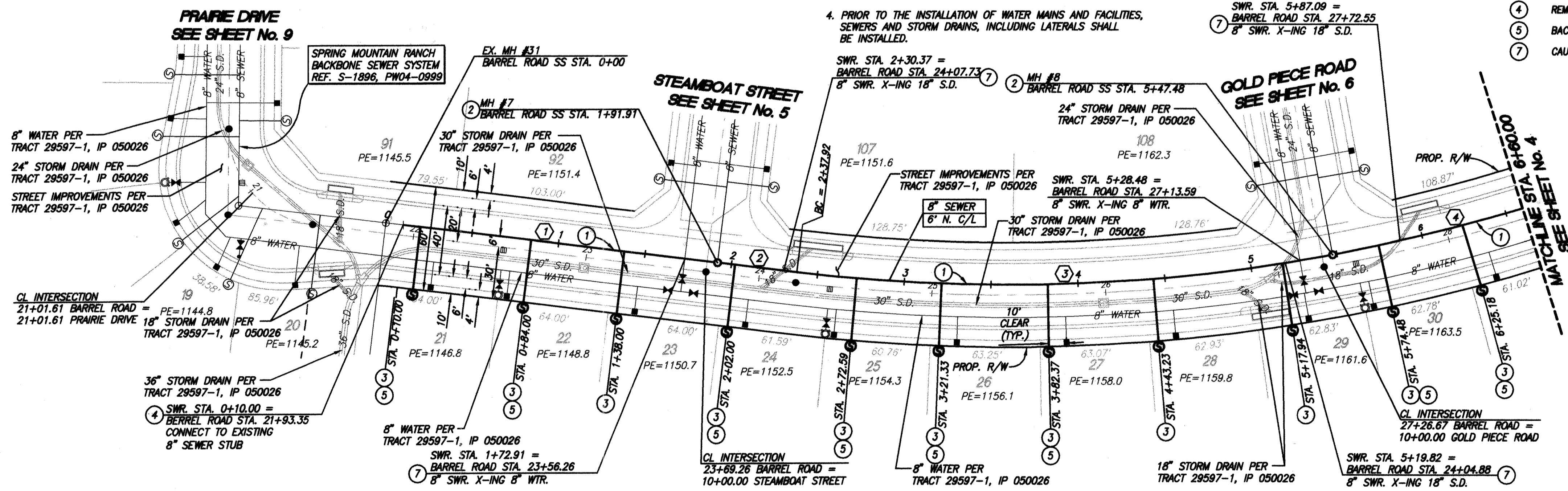

SANITARY SEWER DATA TABLE					
NO.	BEARING/DELTA	RADIUS	LENGTH	TANGENT	REMARKS
1	S82°55'26"E	-	181.91'	-	8" PVC
2	S82°55'26"E	-	46.02'	-	" "
3	17°50'36"	994.00'	308.56'	156.04'	" "
4	06°29'08"	994.00'	112.52'	56.32'	" "

CITY OF RIVERSIDE DRAWING NO. S-1899

WDID No. 833C327881 PW05-0223

TRACT NO. 29597-1 IP NO. 050026

COUNTY OF RIVERSIDE
SEWER IMPROVEMENT PLANS
SPRING MOUNTAIN RANCH

BARREL ROAD

SHEET NO. 3 OF 9 SHTS.

FOR: W.O. COUNTY FILE NO.



NOTE: WORK CONTAINED WITHIN THESE PLANS SHALL NOT COMMENCE UNTIL AN ENCROACHMENT PERMIT AND/OR GRADING PERMIT HAS BEEN ISSUED.

THE PRIVATE ENGINEER SIGNING THESE PLANS IS RESPONSIBLE FOR ASSURING THE ACCURACY AND ACCEPTABILITY OF THE DESIGN HEREON. IN THE EVENT OF DISCREPANCIES AFTER COUNTY APPROVAL OR DURING CONSTRUCTION, THE PRIVATE ENGINEER SHALL BE RESPONSIBLE FOR DETERMINING AN ACCEPTABLE SOLUTION AND REVISING THE PLANS FOR APPROVAL BY THE COUNTY.

DATE	BY	MARK	REVISIONS	APPR.	DATE

SEAL-COUNTY



COUNTY OF RIVERSIDE
TRANSPORTATION DEPARTMENT
APPROVED BY:

KHALED A. OTHMAN DATE: _____
RECOMMENDED DATE: _____

SEAL



STANTEC CONSULTING INC.
277 RANCHEROS DRIVE
SUITE 300
SAN MARCOS, CA 92069
760.891.3200

PREPARED BY: *Kent J. Stepan* R.C.E. NO. 66133
DATE: 1/14/06

CITY OF RIVERSIDE
RECOMMENDS APPROVAL

Tom Prid 1/14/06
CITY ENGINEER DATE

BENCHMARK
SEE BENCHMARK NOTE ON SHEET 1

SCALE: HOR: AS SHOWN VERT: AS SHOWN

K:\3062001\Coad\lmp\lpm\UNIT 1 - 29597\sewer\CS29597-01-03.dwg 1/24/2006 09:46:02 MST

INDEXED 5-02-07 411

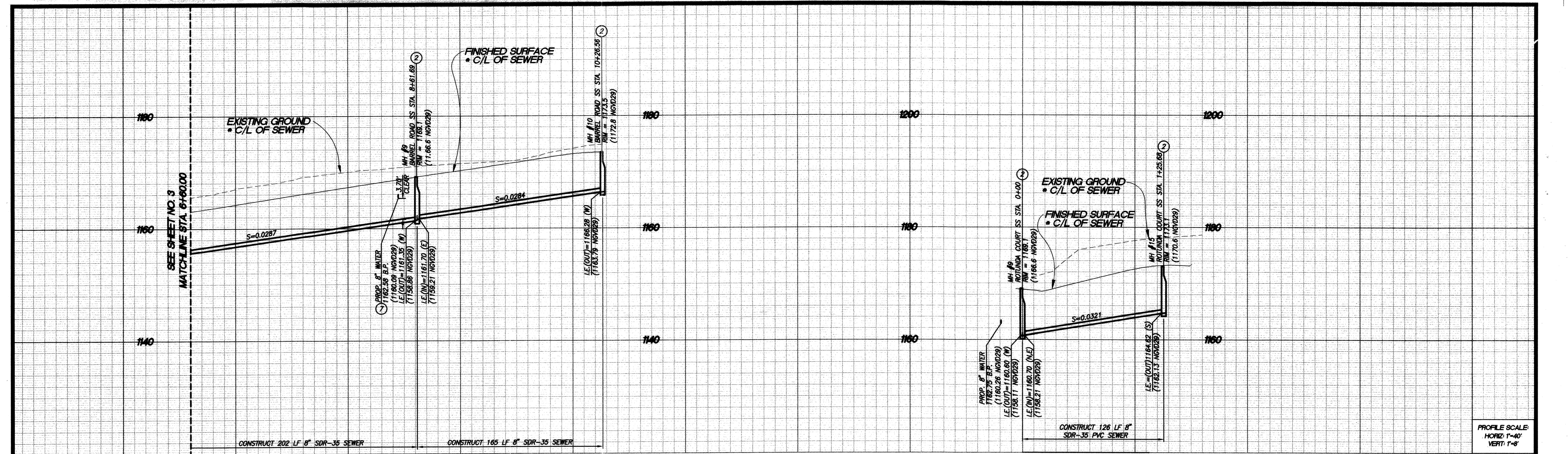

PROFILE SCALE
HORIZ: 1"=40'
VERT: 1"=8'

CONSTRUCTION NOTES

- 1 INSTALL 8" SDR 35 PVC SEWER MAIN. BEDDING PER CITY OF RIVERSIDE STD. DWG. NO. 452
- 2 CONSTRUCT SANITARY SEWER MANHOLE PER CITY OF RIVERSIDE STD. DWG. NO. 500
- 3 INSTALL 4" PVC (SDR 35) SEWER LATERAL W/ CLEANOUT PER CITY OF RIVERSIDE STD. DWG. NO. 562A, 560
- 5 BACKWATER VALVE
- 7 CAUTION! UTILITY CROSSING, SEE PROFILE FOR ELEVATIONS

- NOTE:
1. ALL DATA TABLE LENGTHS ARE MEASURED TO CENTER OF MANHOLE.
 2. ALL PIPE SLOPES ARE CALCULATED FROM INSIDE MANHOLE WALL TO INSIDE MANHOLE WALL.
 3. CONTRACTOR TO VERIFY EXACT LOCATION AND DEPTH OF ALL UNDERGROUND UTILITIES PRIOR TO CONSTRUCTION.
 4. PRIOR TO THE INSTALLATION OF WATER MAINS AND FACILITIES, SEWERS AND STORM DRAINS, INCLUDING LATERALS SHALL BE INSTALLED.

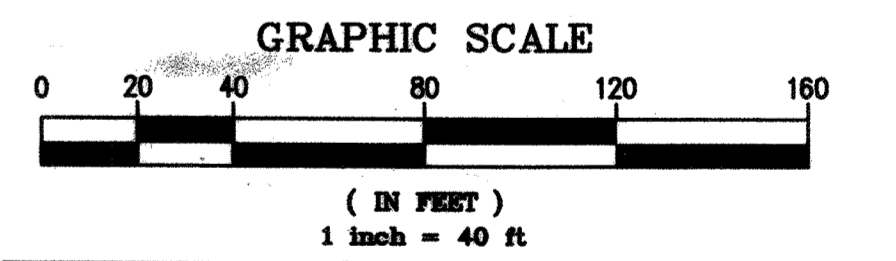
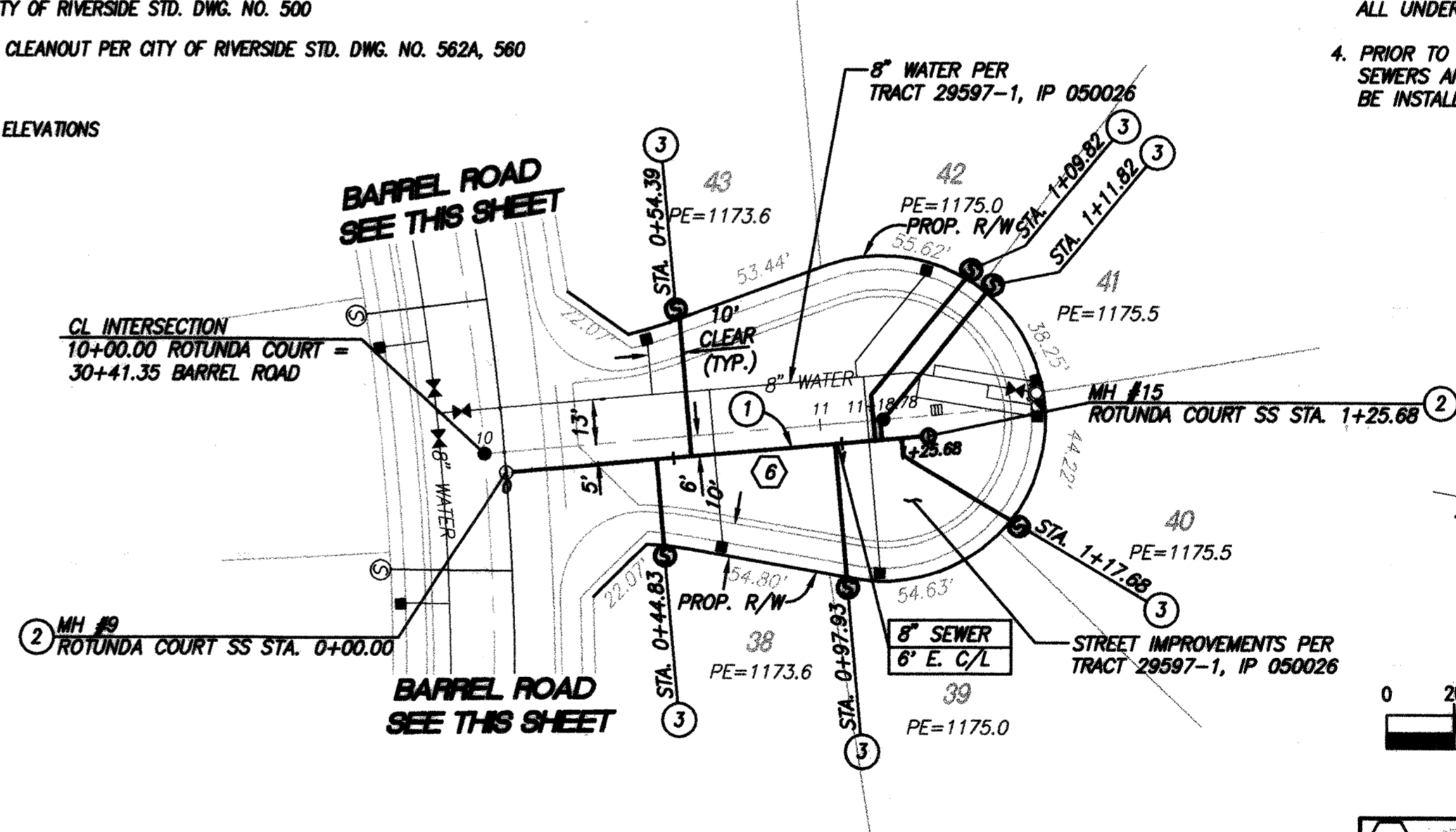
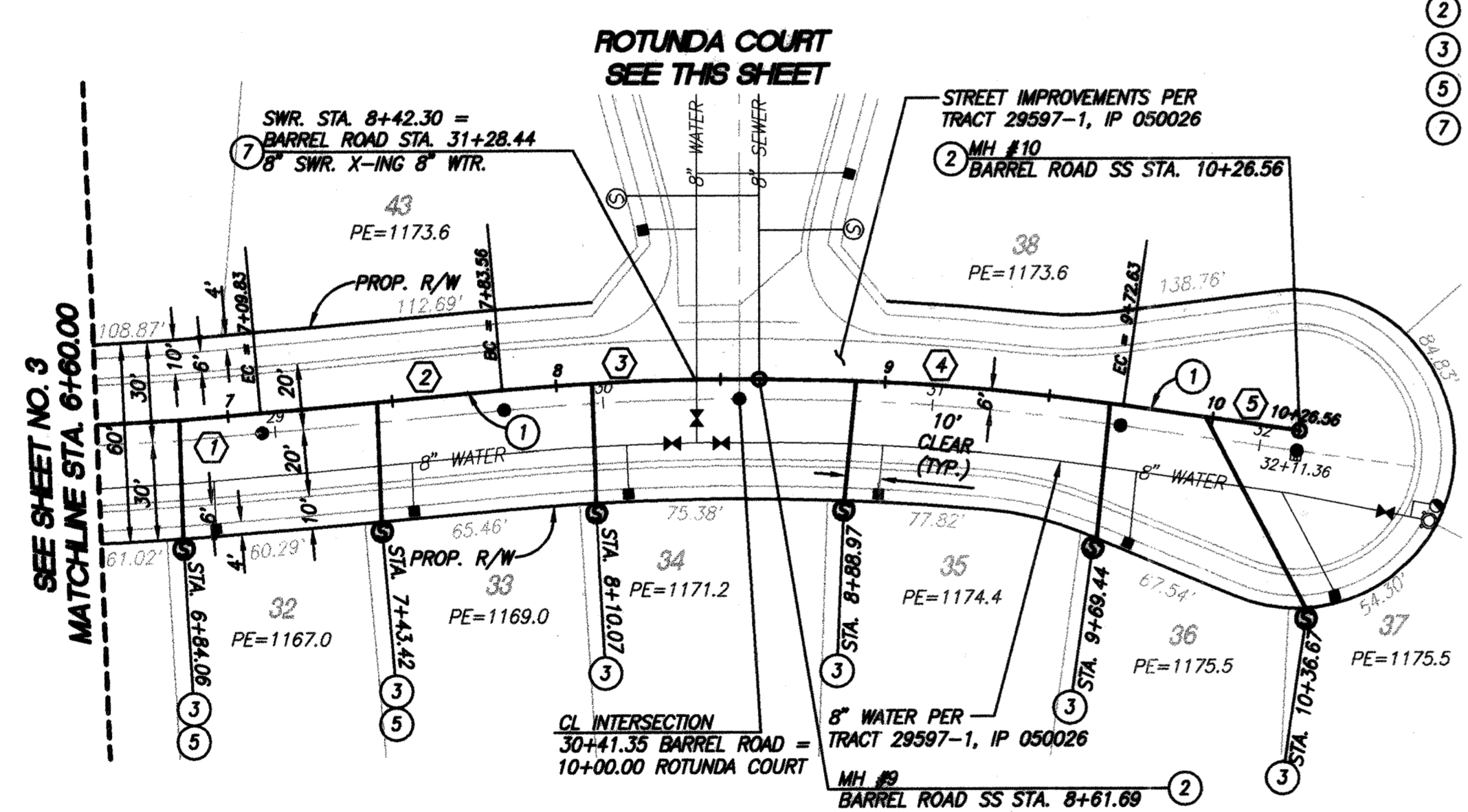

SANITARY SEWER DATA TABLE					
NO.	BEARING/DELTA	RADIUS	LENGTH	TANGENT	REMARKS
1	02°52'26"	994.00'	49.86'	24.93'	8" PVC
2	N69°52'28"E	-	73.73'	-	" "
3	05°33'13"	806.00'	78.12'	39.09'	" "
4	07°53'10"	806.00'	110.94'	55.56'	" "
5	N83°18'51"E	-	53.93'	-	" "
6	S14°59'54"E	-	125.68'	-	" "



NOTE: WORK CONTAINED WITHIN THESE PLANS SHALL NOT COMMENCE UNTIL AN ENCROACHMENT PERMIT AND/OR GRADING PERMIT HAS BEEN ISSUED.

THE PRIVATE ENGINEER SIGNING THESE PLANS IS RESPONSIBLE FOR ASSURING THE ACCURACY AND ACCEPTABILITY OF THE DESIGN HEREON. IN THE EVENT OF DISCREPANCIES AFTER COUNTY APPROVAL OR DURING CONSTRUCTION, THE PRIVATE ENGINEER SHALL BE RESPONSIBLE FOR DETERMINING AN ACCEPTABLE SOLUTION AND REVISING THE PLANS FOR APPROVAL BY THE COUNTY.

DATE	BY	MARK	REVISIONS	APPR.	DATE

SEAL-COUNTY
 COUNTY OF RIVERSIDE
 TRANSPORTATION DEPARTMENT
 APPROVED BY:
 KHALED A. OTHMAN
 DATE: _____

SEAL
 REGISTERED PROFESSIONAL ENGINEER
 KENT J. STEPAN
 No. 66133
 Exp. 6/30/06
 CIVIL
 STATE OF CALIFORNIA

CITY OF RIVERSIDE
 RECOMMENDS APPROVAL
 [Signature]
 CITY ENGINEER
 DATE: 10/27/06

BENCHMARK
 SEE BENCHMARK NOTE ON SHEET 1
 PREPARED BY:
 [Signature]
 KENT J. STEPAN
 R.C.E. NO. 66133
 DATE: 1/24/06
 SCALE: HOR: AS SHOWN VERT: AS SHOWN

CITY OF RIVERSIDE DRAWING NO. S-1899
 WDID No. 833C327881 PW05-0223

TRACT NO. 29597-1 IP NO. 050026
 COUNTY OF RIVERSIDE
 SEWER IMPROVEMENT PLANS
 SPRING MOUNTAIN RANCH
BARREL ROAD & ROTUNDA COURT
 SHEET NO. 4
 OF 9 SHTS.

INDEXED 5-02-07 LPH

K:\3062001\Cadd\p\p\unit 1 - 29597 Sewer\29597-01-04.dwg 1/24/2006 4:34:03 PM MST

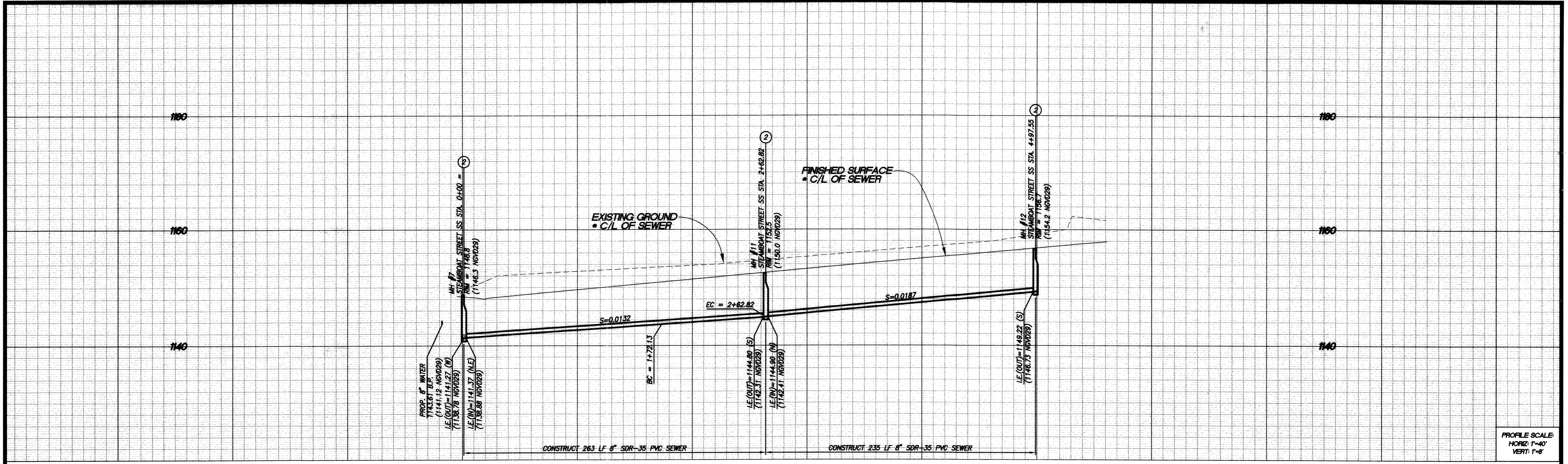

PROFILE SCALE:
HORIZ: 1"=40'
VERT: 1"=8'

CONSTRUCTION NOTES

1. INSTALL 8" SDR 35 PVC SEWER MAIN. BEDDING PER CITY OF RIVERSIDE STD. DWG. NO. 452
2. CONSTRUCT SANITARY SEWER MANHOLE PER CITY OF RIVERSIDE STD. DWG. NO. 500
3. INSTALL 4" PVC (SDR 35) SEWER LATERAL W/ CLEANOUT PER CITY OF RIVERSIDE STD. DWG. NO. 562A, 560
5. BACKWATER VALVE

- NOTE:
1. ALL DATA TABLE LENGTHS ARE MEASURED TO CENTER OF MANHOLE.
 2. ALL PIPE SLOPES ARE CALCULATED FROM INSIDE MANHOLE WALL TO INSIDE MANHOLE WALL.
 3. CONTRACTOR TO VERIFY EXACT LOCATION AND DEPTH OF ALL UNDERGROUND UTILITIES PRIOR TO CONSTRUCTION.
 4. PRIOR TO THE INSTALLATION OF WATER MAINS AND FACILITIES, SEWERS AND STORM DRAINS, INCLUDING LATERALS SHALL BE INSTALLED.

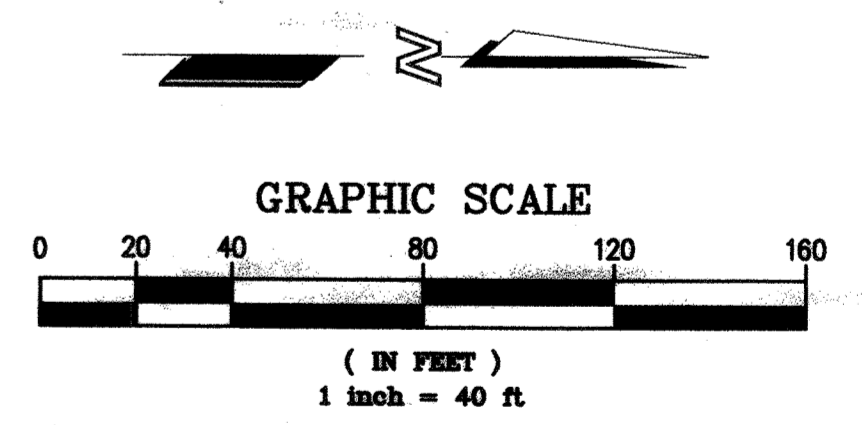
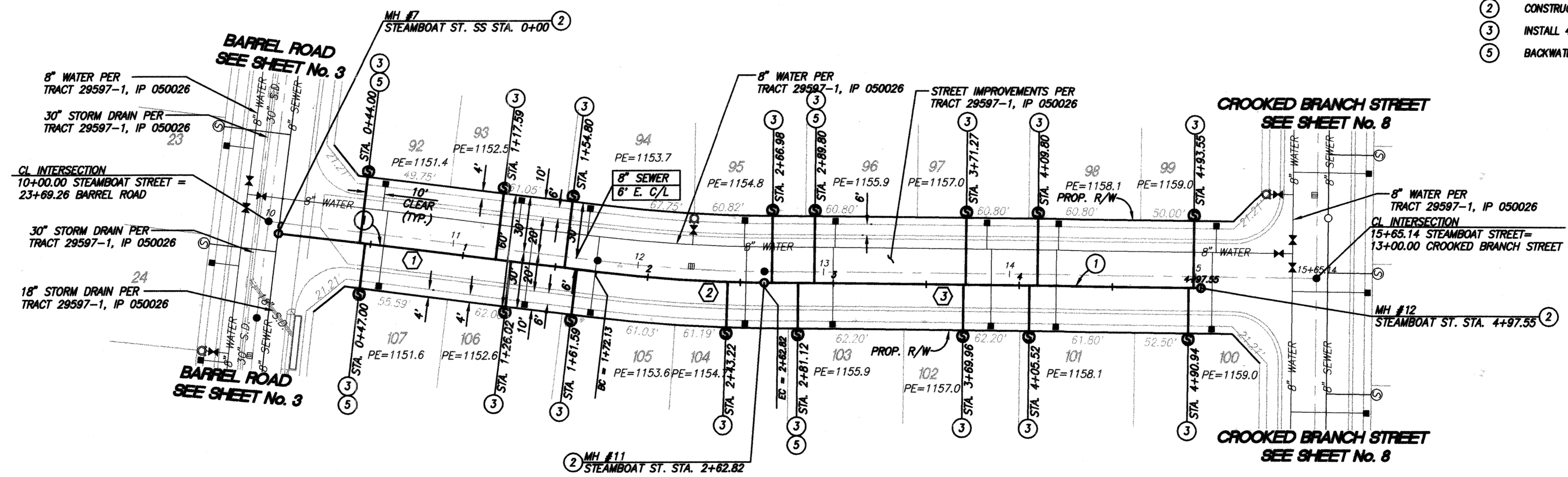

SANITARY SEWER DATA TABLE					
NO.	BEARING/Delta	RADIUS	LENGTH	TANGENT	REMARKS
1	N07°04'34"E	-	178.13'	-	8" PVC
2	06°26'51"	806.00'	90.02'	45.06'	" "
3	N00°37'43"E	-	296.99'	-	" "

CITY OF RIVERSIDE DRAWING NO. S-1899

WDID No. 833C327881 PW05-0223

TRACT NO. 29597-1 IP NO. 050026 SHEET NO.

COUNTY OF RIVERSIDE
SEWER IMPROVEMENT PLANS
SPRING MOUNTAIN RANCH

STEAMBOAT STREET

OF 9 SHTS.

FOR: W.O. COUNTY FILE NO.

NOTES:
STREET RIGHT-OF-WAY DEDICATION PER TRACT NO. 29597-1, M.B. 1

CITY OF RIVERSIDE
RECOMMENDS APPROVAL

Shm Byd 10/21/06
CITY ENGINEER DATE

BENCHMARK
SEE BENCHMARK NOTE ON SHEET 1

STANTEC CONSULTING INC.
277 RANCHEROS DRIVE
SUITE 300
SAN MARCOS, CA 92069
760.891.3200

PREPARED BY: *Kent J. Stepan* R.C.E. No. 66133
DATE: 1/16/06

SCALE:
HOR: AS SHOWN VERT: AS SHOWN

STEAMBOAT STREET

SEAL-COUNTY
COUNTY OF RIVERSIDE
TRANSPORTATION DEPARTMENT
APPROVED BY:
KHALED A. OTHMAN DATE:
RECOMMENDED DATE:

SEAL
REGISTERED PROFESSIONAL ENGINEER
KENT J. STEPAN
No. 66133
Exp. 06-30-08
CIVIL
STATE OF CALIFORNIA



NOTE: WORK CONTAINED WITHIN THESE PLANS SHALL NOT COMMENCE UNTIL AN ENCROACHMENT PERMIT AND/OR GRADING PERMIT HAS BEEN ISSUED.

THE PRIVATE ENGINEER SIGNING THESE PLANS IS RESPONSIBLE FOR ASSURING THE ACCURACY AND ACCEPTABILITY OF THE DESIGN HEREON. IN THE EVENT OF DISCREPANCIES AFTER COUNTY APPROVAL OR DURING CONSTRUCTION, THE PRIVATE ENGINEER SHALL BE RESPONSIBLE FOR DETERMINING AN ACCEPTABLE SOLUTION AND REVISING THE PLANS FOR APPROVAL BY THE COUNTY.

DATE	BY	MARK	REVISIONS	APPR. DATE	COUNTY

K:\306200\Cadd\Imp-plan\UNIT 1 - 29597 Sewer\29597-01-05.dwg 1/24/2006 09:50:31 MST

INDEXED 5-02-07 LFT

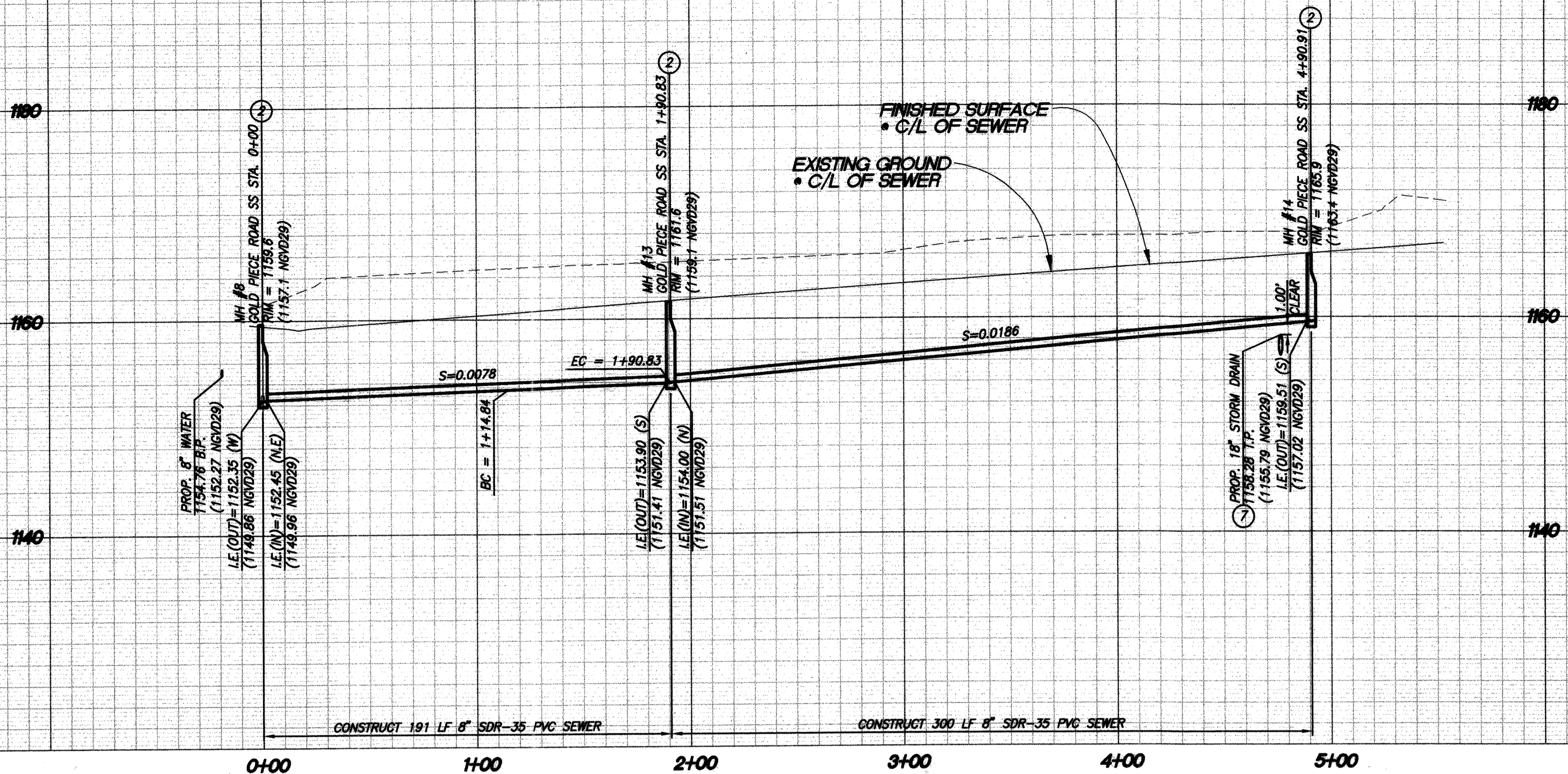

PROFILE SCALE:
HORIZ: 1"=40'
VERT: 1"=8'

CONSTRUCTION NOTES

1. INSTALL 8" SDR 35 PVC SEWER MAIN. BEDDING PER CITY OF RIVERSIDE STD. DWG. NO. 452
2. CONSTRUCT SANITARY SEWER MANHOLE PER CITY OF RIVERSIDE STD. DWG. NO. 500
3. INSTALL 4" PVC (SDR 35) SEWER LATERAL W/ CLEANOUT PER CITY OF RIVERSIDE STD. DWG. NO. 562A, 560
5. BACKWATER VALVE
7. CAUTION! UTILITY CROSSING, SEE PROFILE FOR ELEVATIONS

- NOTE:**
1. ALL DATA TABLE LENGTHS ARE MEASURED TO CENTER OF MANHOLE.
 2. ALL PIPE SLOPES ARE CALCULATED FROM INSIDE MANHOLE WALL TO INSIDE MANHOLE WALL.
 3. CONTRACTOR TO VERIFY EXACT LOCATION AND DEPTH OF ALL UNDERGROUND UTILITIES PRIOR TO CONSTRUCTION.
 4. PRIOR TO THE INSTALLATION OF WATER MAINS AND FACILITIES, SEWERS AND STORM DRAINS, INCLUDING LATERALS SHALL BE INSTALLED.

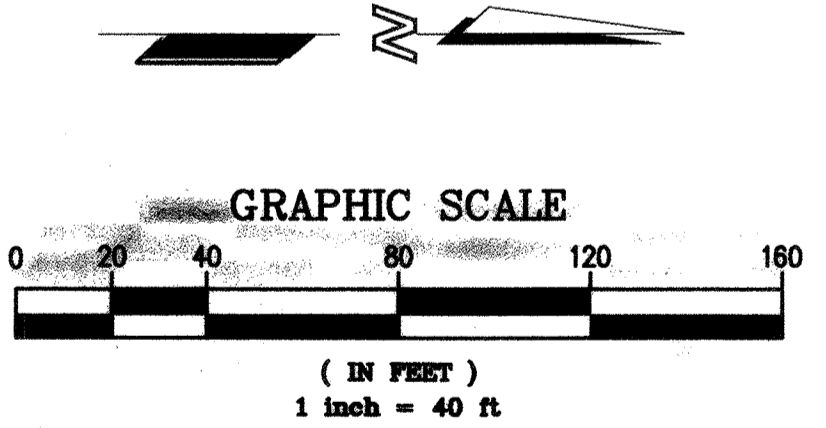
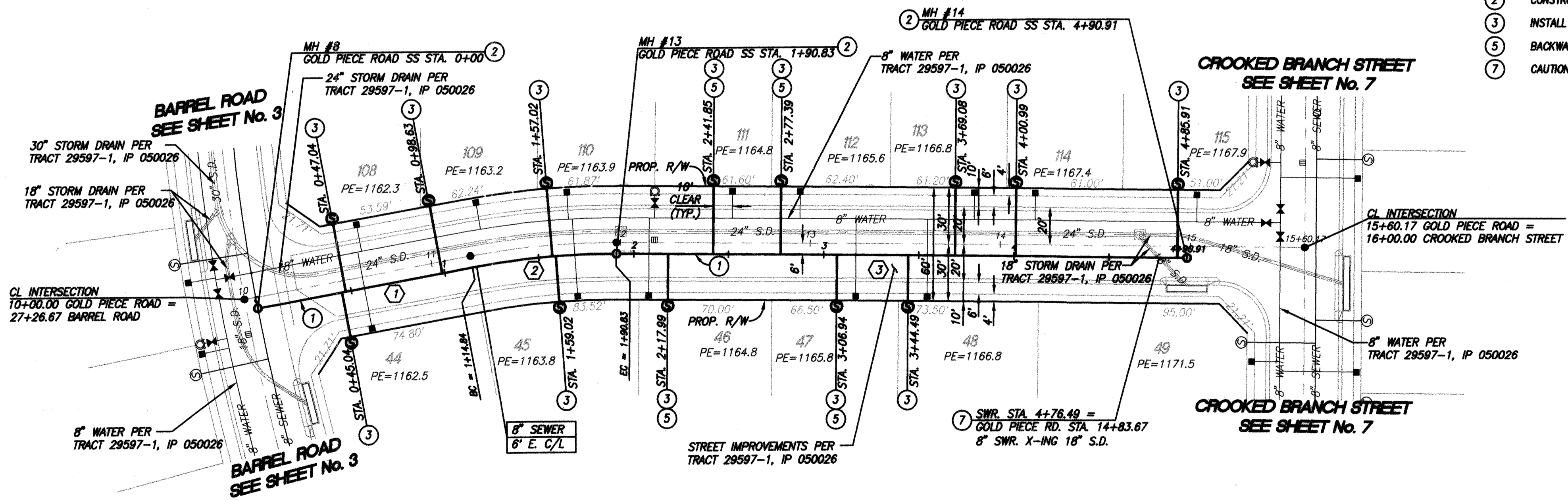

SANITARY SEWER DATA TABLE					
NO.	BEARING/Delta	RADIUS	LENGTH	TANGENT	REMARKS
1	N10°25'17"W	-	114.84'	-	8" PVC
2	11°03'00"	394.00'	75.99'	38.11'	" "
3	N00°37'43"E	-	300.08'	-	" "



NOTE: WORK CONTAINED WITHIN THESE PLANS SHALL NOT COMMENCE UNTIL AN ENCROACHMENT PERMIT AND/OR GRADING PERMIT HAS BEEN ISSUED.

THE PRIVATE ENGINEER SIGNING THESE PLANS IS RESPONSIBLE FOR ASSURING THE ACCURACY AND ACCEPTABILITY OF THE DESIGN HEREON. IN THE EVENT OF DISCREPANCIES AFTER COUNTY APPROVAL OR DURING CONSTRUCTION, THE PRIVATE ENGINEER SHALL BE RESPONSIBLE FOR DETERMINING AN ACCEPTABLE SOLUTION AND REVISING THE PLANS FOR APPROVAL BY THE COUNTY.

DATE	BY	MARK	REVISIONS	APPR.	DATE

SEAL-COUNTY

COUNTY OF RIVERSIDE
TRANSPORTATION DEPARTMENT
APPROVED BY:

KHALED A. OTHMAN

DATE: _____

RECOMMENDED

DATE: _____

SEAL

REGISTERED PROFESSIONAL ENGINEER
KENT J. STEPAN
No. 66133
Exp. 06-30-06
CIVIL
STATE OF CALIFORNIA

STANTEC CONSULTING INC.
277 RANCHEROS DRIVE
SUITE 300
SAN MARCOS, CA 92069
760.891.3200

PREPARED BY: *Kent J. Stepan*

R.C.E. NO. 66133

DATE: 1/21/06

CITY OF RIVERSIDE
RECOMMENDS APPROVAL

Tom Bad 1/21/06
CITY ENGINEER
DATE

BENCHMARK
SEE BENCHMARK NOTE ON SHEET 1

SCALE:
HOR: AS SHOWN VERT: AS SHOWN

CITY OF RIVERSIDE DRAWING NO. S-1899

WDID No. 833C327881 PW05-0223

TRACT NO. 29597-1 IP NO. 050028

COUNTY OF RIVERSIDE
SEWER IMPROVEMENT PLANS
SPRING MOUNTAIN RANCH

GOLD PIECE ROAD

SHEET NO. 6 OF 9 SHTS.

FOR: _____ W.O. _____ COUNTY FILE NO. _____

INDEXED 5-02-07 LFH

K:\306200\Coord\Imp-plan\UNIT 1 - 29597\sewer\plan\UNIT 1 - 29597.dwg 1/24/2006 09:56:46 MST

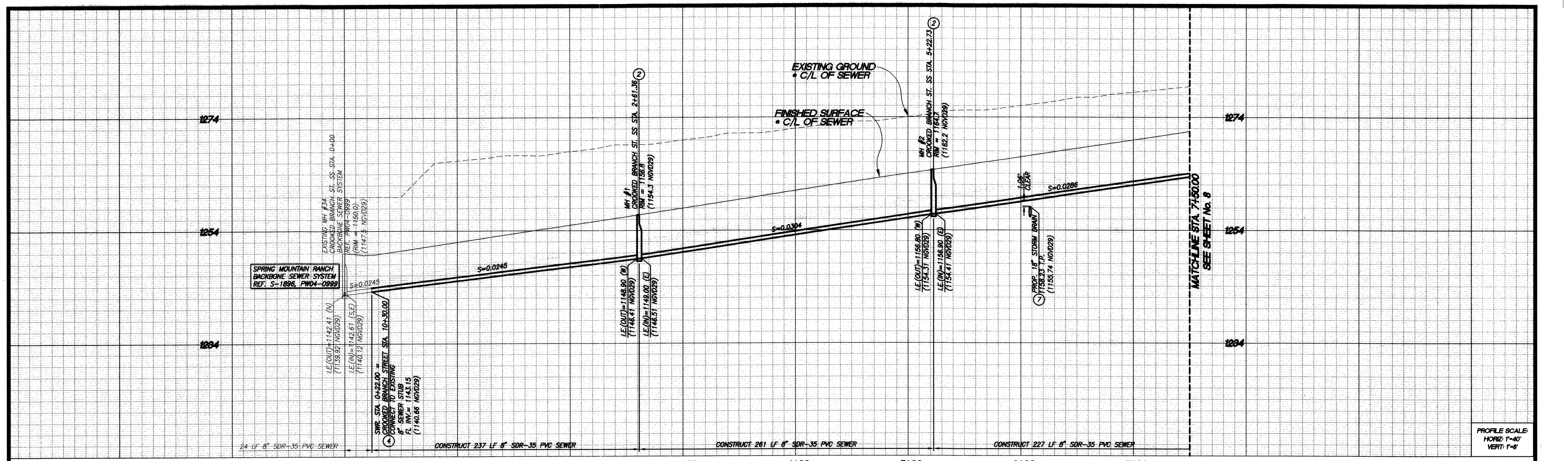

PROFILE SCALE
HORIZ: 1"=40'
VERT: 1"=8'

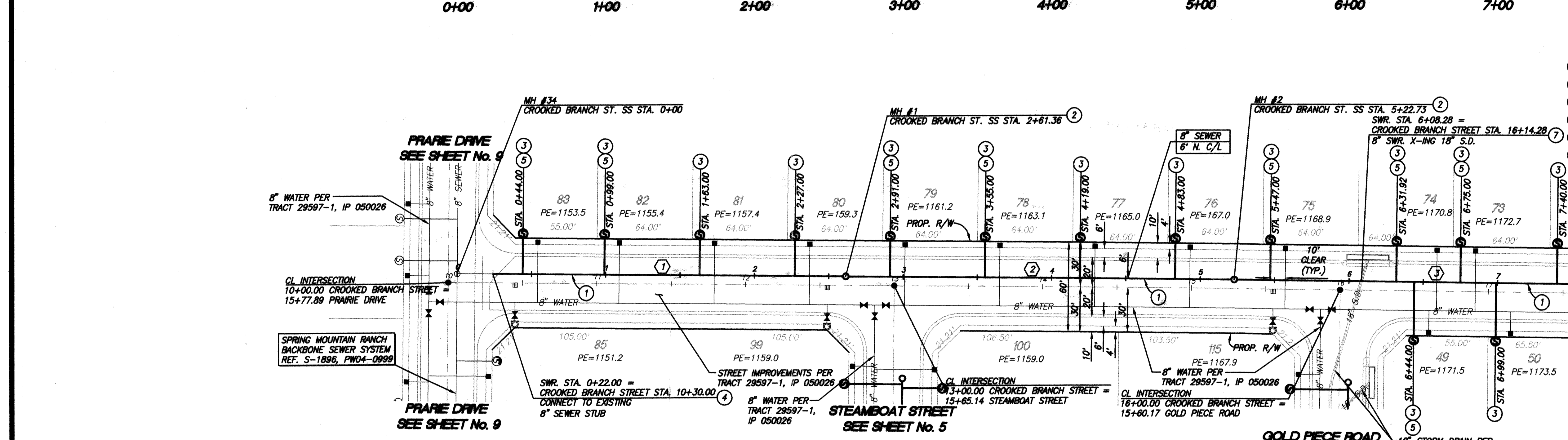

CONSTRUCTION NOTES

1. INSTALL 8" SDR 35 PVC SEWER MAIN. BEDDING PER CITY OF RIVERSIDE STD. DWG. NO. 452
2. CONSTRUCT SANITARY SEWER MANHOLE PER CITY OF RIVERSIDE STD. DWG. NO. 500
3. INSTALL 4" PVC (SDR 35) SEWER LATERAL W/ CLEANOUT PER CITY OF RIVERSIDE STD. DWG. NO. 562A, 560
4. REMOVE 8" PLUG
5. BACKWATER VALVE
6. CAUTION! UTILITY CROSSING, SEE PROFILE FOR ELEVATIONS

- NOTE:**
1. ALL DATA TABLE LENGTHS ARE MEASURED TO CENTER OF MANHOLE.
 2. ALL PIPE SLOPES ARE CALCULATED FROM INSIDE MANHOLE WALL TO INSIDE MANHOLE WALL.
 3. CONTRACTOR TO VERIFY EXACT LOCATION AND DEPTH OF ALL UNDERGROUND UTILITIES PRIOR TO CONSTRUCTION.
 4. PRIOR TO THE INSTALLATION OF WATER MAINS AND FACILITIES, SEWERS AND STORM DRAINS, INCLUDING LATERALS SHALL BE INSTALLED.

SANITARY SEWER DATA TABLE					
NO.	BEARING/DELTA	RADIUS	LENGTH	TANGENT	REMARKS
1	S89°22'17"E	-	237.36'	-	8" PVC
2	S89°22'17"E	-	261.36'	-	"
3	S89°22'17"E	-	227.25'	-	"

CITY OF RIVERSIDE
RECOMMENDS APPROVAL

[Signature] 10/27/06
CITY ENGINEER DATE

CITY OF RIVERSIDE DRAWING NO. S-1899
WDID No. 833C327881 PW05-0223

TRACT NO. 29597-1 IP NO. 050026 SHEET NO. 7

COUNTY OF RIVERSIDE
SEWER IMPROVEMENT PLANS
SPRING MOUNTAIN RANCH

CROOKED BRANCH STREET OF 9 SHTS.



NOTE: WORK CONTAINED WITHIN THESE PLANS SHALL NOT COMMENCE UNTIL AN ENCROACHMENT PERMIT AND/OR GRADING PERMIT HAS BEEN ISSUED.

THE PRIVATE ENGINEER SIGNING THESE PLANS IS RESPONSIBLE FOR ASSURING THE ACCURACY AND ACCEPTABILITY OF THE DESIGN HEREON. IN THE EVENT OF DISCREPANCIES AFTER COUNTY APPROVAL OR DURING CONSTRUCTION, THE PRIVATE ENGINEER SHALL BE RESPONSIBLE FOR DETERMINING AN ACCEPTABLE SOLUTION AND REVISIONS TO THE PLANS FOR APPROVAL BY THE COUNTY.

DATE	BY	MARK	REVISIONS	APPR.	DATE

SEAL-COUNTY
COUNTY OF RIVERSIDE
TRANSPORTATION DEPARTMENT
APPROVED BY:
KHALED A. OTHMAN DATE: _____

SEAL
REGISTERED PROFESSIONAL ENGINEER
KENT J. STEPAN
No. 33950 Exp. 6/30/06
CIVIL
STATE OF CALIFORNIA

STANTEC CONSULTING INC.
277 RANCHEROS DRIVE
SUITE 300
SAN MARCOS, CA 92069
760.891.3200

PREPARED BY: *[Signature]* R.C.E. NO. 56133
DATE: 1/21/06

BENCHMARK
SEE BENCHMARK NOTE ON SHEET 1

SCALE:
HOR: AS SHOWN VERT: AS SHOWN

FOR: W.O. COUNTY FILE NO.

INDEXED 5-02-07 (4)

K:\306200\Cadd\Imp-plan\UNIT 1 - 29597A Sewer\S29597-01-07.dwg 1/24/2006 10:18:54 MST

NOTE: WORK CONTAINED WITHIN THESE PLANS SHALL NOT COMMENCE UNTIL AN ENCROACHMENT PERMIT AND/OR GRADING PERMIT HAS BEEN ISSUED.
THE PRIVATE ENGINEER SHOWING THESE PLANS IS RESPONSIBLE FOR ASSURING THE ACCURACY AND ACCEPTABILITY OF THE DESIGN. IN THE EVENT OF DISCREPANCIES AFTER COUNTY REVIEW OR DURING CONSTRUCTION, THE PRIVATE ENGINEER SHALL BE RESPONSIBLE FOR DETERMINING AN ACCEPTABLE SOLUTION AND REVISING THE PLANS FOR APPROVAL BY THE COUNTY.

ENGINEER	DATE	BY	MARK



APPROVED BY: MOHAMED A. OTHMAN
DATE: _____
COUNTY OF RIVERSIDE
TRANSPORTATION DEPARTMENT

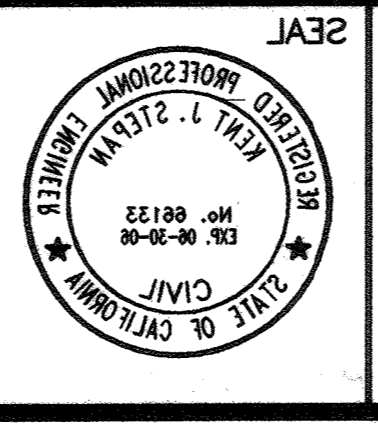

PREPARED BY: KENT J. STEPAN
DATE: 11/27/07
R.C.E. NO. 68133
STATIST CONSULTING INC.
700 861.3200
SUITE 300
327 RANCHEROS DRIVE
SAN MARCOS, CA 92069

FOR: W.O.
SCALE: HOR. AS SHOWN VERT. AS SHOWN
SEE BENCHMARK NOTE ON SHEET 1
CITY ENGINEER: _____
DATE: 10/27/08
RECOMMENDS APPROVAL: _____
CITY OF RIVERSIDE

INDEXED 2-05-07
CROOKED BRANCH STREET
SPRING MOUNTAIN BRANCH
COUNTY OF RIVERSIDE
TRACT NO. 28987-1, P. NO. 080058
SHEET NO. 8
WCD ID NO. 833C373881
PWO2-0523
CITY OF RIVERSIDE DRAWING NO. 2-1869

NO.	BEARING	DELTA	LENGTH	RADIUS	REMARKS
1	S88°23'17"E	-	25.30'	-	8" PVC
2	S75°27'17"	308.00'	1.78'23"	81.72'	" "
3	S28°00'0"E	-	218.30'	-	" "
4	S28°00'0"E	-	234'48"	-	" "

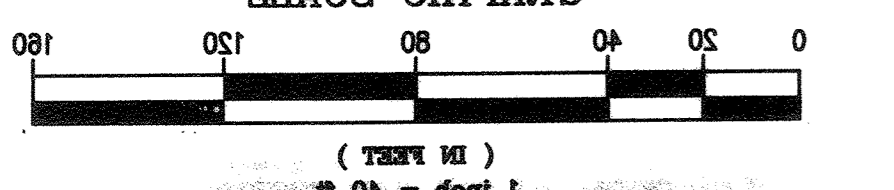

- 1. ALL DATA TABLE LENGTHS ARE MEASURED TO CENTER OF MANHOLE.
- 2. ALL PIPE SLOPES ARE CALCULATED FROM INSIDE MANHOLE WALL TO INSIDE MANHOLE WALL.
- 3. CONTRACTOR TO VERIFY EXACT LOCATION AND DEPTH OF ALL UNDERGROUND UTILITIES PRIOR TO CONSTRUCTION.
- 4. PRIOR TO THE INSTALLATION OF WATER MAINS AND FACILITIES, SEWERS AND STORM DRAINAGE INCLUDING LATERALS SHALL BE INSTALLED.
- 5. CAUTION UTILITY CROSSING SEE PROFILE FOR ELEVATIONS.
- 6. BACKWATER VALVE.
- 7. INSTALL 4" PVC (20' 28) SEWER LATERAL W/ CLEANOUT PER CITY OF RIVERSIDE STD. DWG. NO. 282A.
- 8. CONSTRUCT SANITARY SEWER MANHOLE PER CITY OF RIVERSIDE STD. DWG. NO. 200.
- 9. INSTALL 8" 20R 28 PVC SEWER MAIN BEDDING PER CITY OF RIVERSIDE STD. DWG. NO. 432.

CONSTRUCTION NOTES

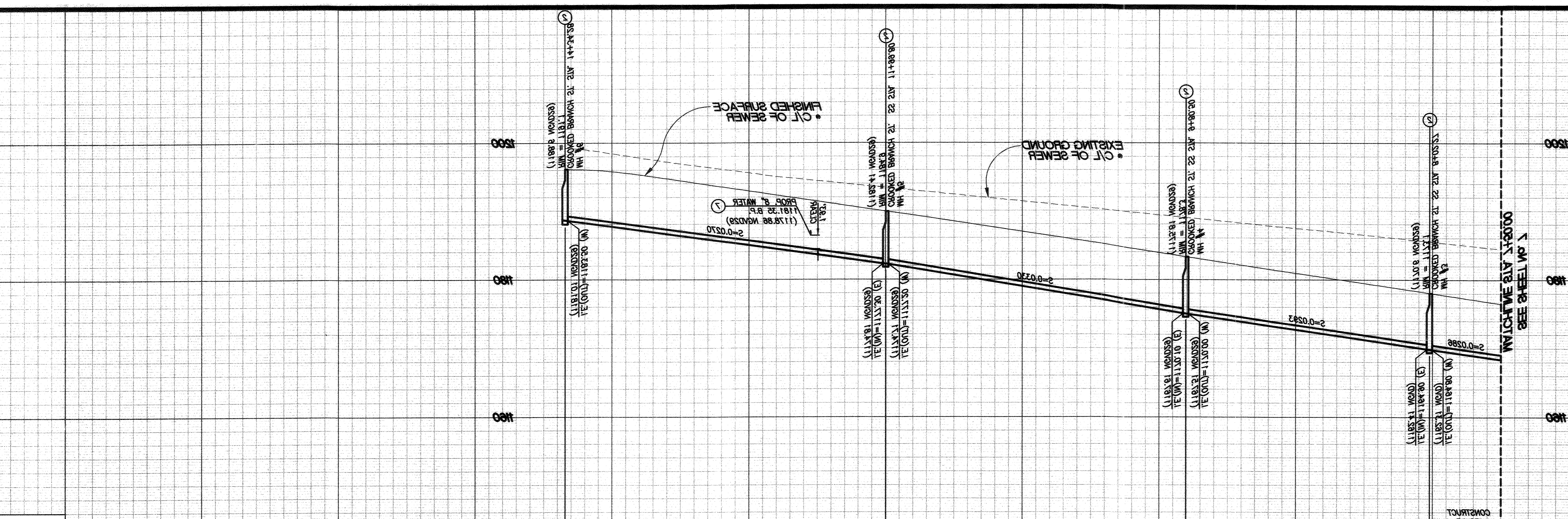
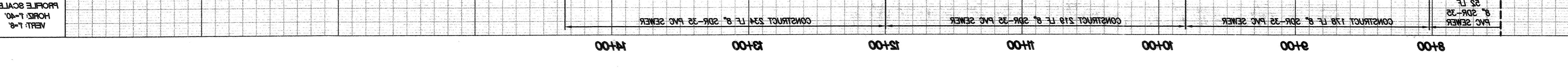
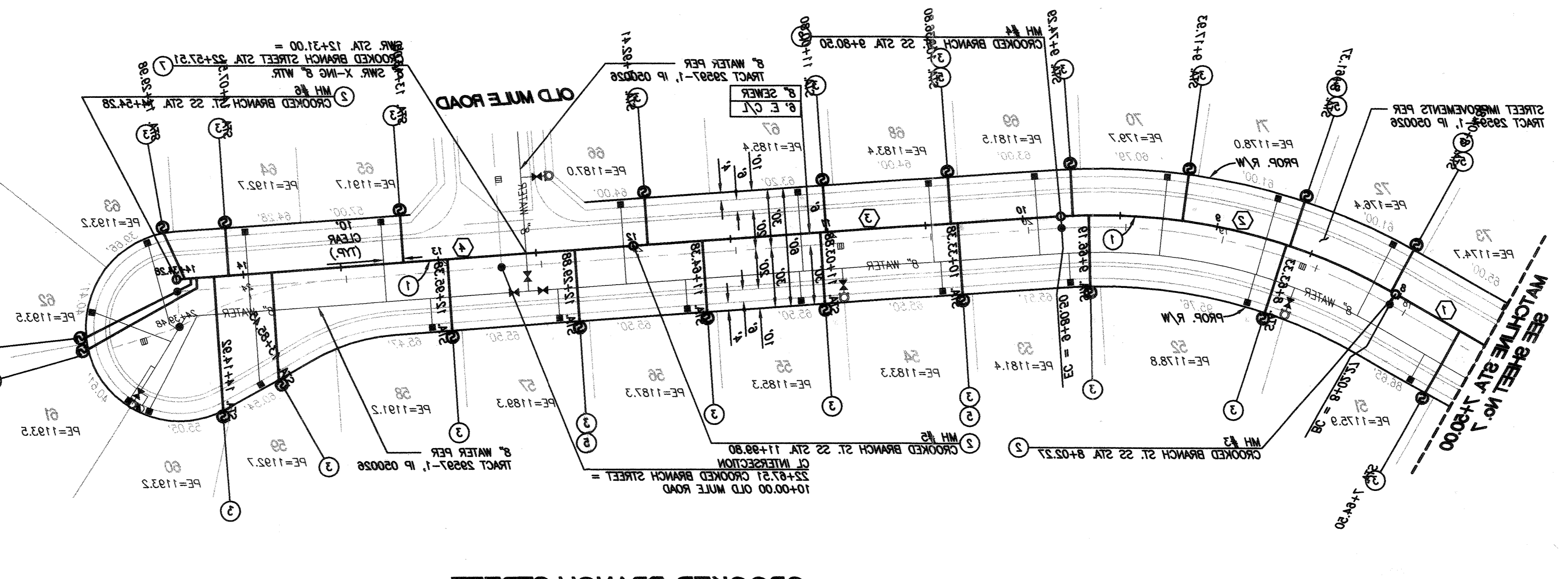

DATE: 11/27/07
R.C.E. NO. 68133
STATIST CONSULTING INC.
700 861.3200
SUITE 300
327 RANCHEROS DRIVE
SAN MARCOS, CA 92069
CITY OF RIVERSIDE
CROOKED BRANCH STREET
SPRING MOUNTAIN BRANCH
COUNTY OF RIVERSIDE
TRACT NO. 28987-1, P. NO. 080058
SHEET NO. 8
WCD ID NO. 833C373881
PWO2-0523
CITY OF RIVERSIDE DRAWING NO. 2-1869
INDEXED 2-05-07

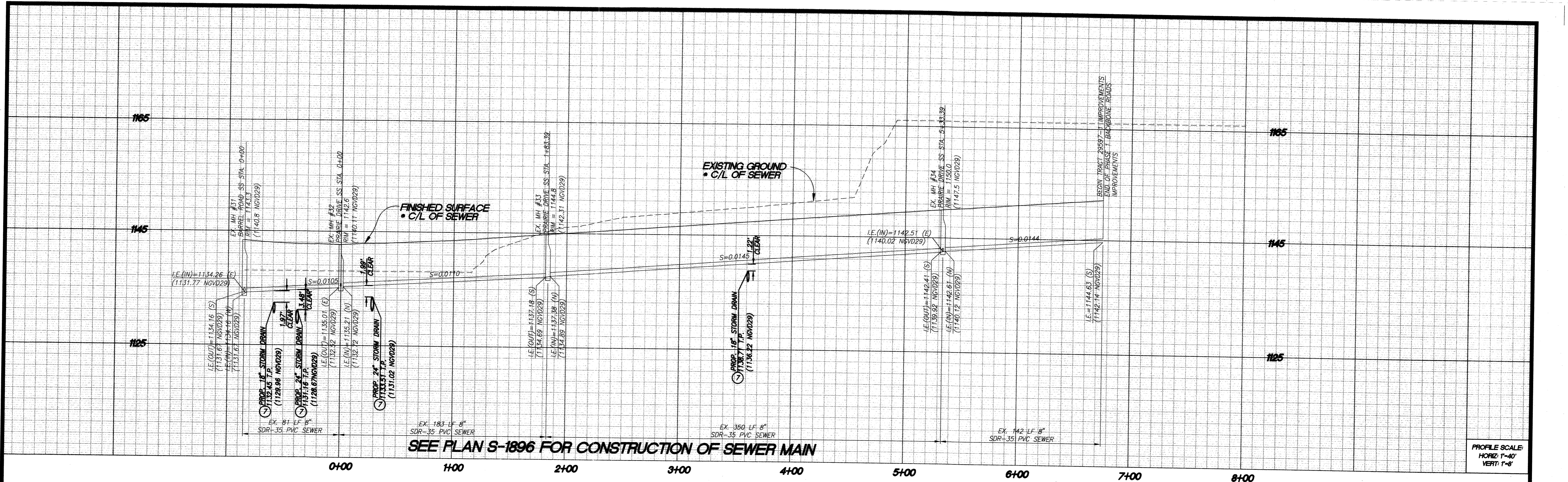

PROFILE SCALE:
HORIZ: 1"=40'
VERT: 1"=8'

CONSTRUCTION NOTES

- 3 INSTALL 4" PVC (SDR 35) SEWER LATERAL W/ CLEANOUT PER CITY OF RIVERSIDE STD. DWG. NO. 562A, 560
- 5 BACKWATER VALVE
- 7 CAUTION! UTILITY CROSSING, SEE PROFILE FOR ELEVATIONS

- NOTE:**
1. ALL DATA TABLE LENGTHS ARE MEASURED TO CENTER OF MANHOLE.
 2. ALL PIPE SLOPES ARE CALCULATED FROM INSIDE MANHOLE WALL TO INSIDE MANHOLE WALL.
 3. CONTRACTOR TO VERIFY EXACT LOCATION AND DEPTH OF ALL UNDERGROUND UTILITIES PRIOR TO CONSTRUCTION.
 4. PRIOR TO THE INSTALLATION OF WATER MAINS AND FACILITIES, SEWERS AND STORM DRAINS, INCLUDING LATERALS SHALL BE INSTALLED.

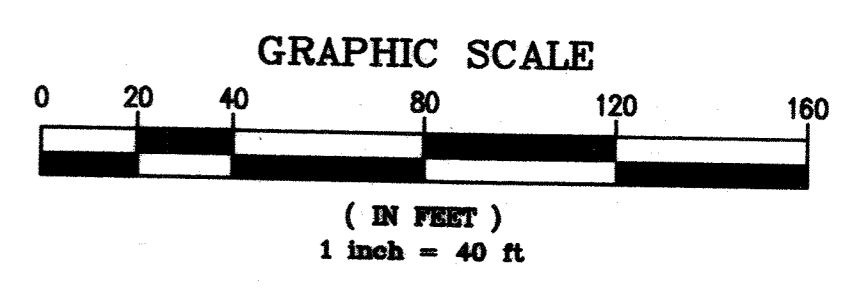
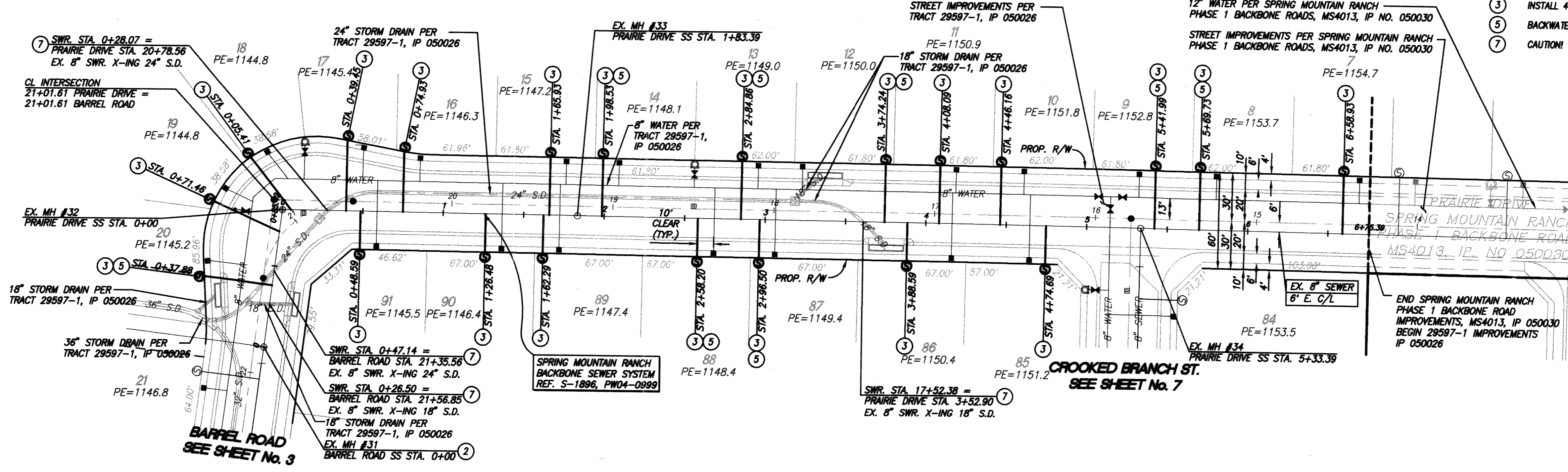

NOTE: WORK CONTAINED WITHIN THESE PLANS SHALL NOT COMMENCE UNTIL AN ENCROACHMENT PERMIT AND/OR GRADING PERMIT HAS BEEN ISSUED.

THE PRIVATE ENGINEER SIGNING THESE PLANS IS RESPONSIBLE FOR ASSURING THE ACCURACY AND ACCEPTABILITY OF THE DESIGN HEREON. IN THE EVENT OF DISCREPANCIES AFTER COUNTY APPROVAL OR DURING CONSTRUCTION, THE PRIVATE ENGINEER SHALL BE RESPONSIBLE FOR DETERMINING AN ACCEPTABLE SOLUTION AND REVISING THE PLANS FOR APPROVAL BY THE COUNTY.

DATE	BY	MARK	REVISIONS	APPR.	DATE

SEAL-COUNTY

COUNTY OF RIVERSIDE
TRANSPORTATION DEPARTMENT
APPROVED BY:

KHALED A. OTHMAN

SEAL

REGISTERED PROFESSIONAL ENGINEER
KENT J. STEPAN
No. 86133
Exp. 08-30-08
CIVIL
STATE OF CALIFORNIA

STANTEC CONSULTING INC.
277 RANCHEROS DRIVE
SUITE 300
SAN MARCOS, CA 92069
760.891.3200

PREPARED BY: *Kent J. Stephan* R.C.E. No. 86133
DATE: *10/2/06*

CITY OF RIVERSIDE
RECOMMENDS APPROVAL

Alan B. ... 10/2/06
CITY ENGINEER DATE

CITY OF RIVERSIDE DRAWING NO. S-1899

WDID No. 833C327881 PW05-0223

TRACT NO. 29597-1 IP NO. 050026

COUNTY OF RIVERSIDE
SEWER IMPROVEMENT PLANS
SPRING MOUNTAIN RANCH

PRAIRIE DRIVE

SHEET NO. **9**
OF **9** SHTS.

FOR: W.O. COUNTY FILE NO.

INDEXED 5-02-07

K:\3062001\Good\Imp-plan\UNIT 1 - 295971 Sewer\529597-01-09.dwg 1/24/2006 10:26:47 MST