

# IN THE CITY OF RIVERSIDE, CALIFORNIA

## SEWER IMPROVEMENT PLANS

### TRACT 32772-1

**GENERAL NOTES**

1. THE PRIVATE ENGINEER SIGNING THESE PLANS IS RESPONSIBLE FOR ASSURING THE ACCURACY AND ACCEPTABILITY OF THE WORK HEREON. IN THE EVENT OF DISCREPANCIES ARISING DURING CONSTRUCTION, THE PRIVATE ENGINEER SHALL BE RESPONSIBLE FOR DETERMINING AN ACCEPTABLE SOLUTION AND REVISING THE PLANS FOR APPROVAL BY THE CITY.
2. IT SHALL BE THE RESPONSIBILITY OF THE CONTRACTOR TO CLEAR THE RIGHT OF WAY IN ACCORDANCE WITH THE PROVISIONS OF LAW AS IT AFFECTS EACH UTILITY INCLUDING IRRIGATION LINES AND APPURTENANCES AND AT NO COST TO THE CITY.
3. CONSTRUCTION SHALL BE IN ACCORDANCE WITH THE CITY OF RIVERSIDE DEPT. OF PUBLIC WORKS, STANDARD DRAWINGS, ITS SUPPLEMENTAL NOTES AND THE STANDARD SPECIFICATIONS FOR PUBLIC WORKS CONSTRUCTION, CURRENT EDITION.
4. CONTRACTOR IS TO VERIFY EXISTING SEWER ELEVATION PRIOR TO CONSTRUCTION.
5. THE SEWER CONTRACTOR SHALL ADJUST MANHOLES TO FINAL GRADE AFTER PAVING IS COMPLETED.
6. A PLUG SHALL BE INSTALLED AND WILL REMAIN IN PLACE WHERE THE NEW SEWER CONNECTS WITH THE EXISTING SEWER UNTIL THE NEW SEWER IS ACCEPTED BY THE CITY OF RIVERSIDE.
7. ANY TRAFFIC CONTROL STRIPING OBLITERATED AND/OR BADLY WORN DURING CONSTRUCTION SHALL BE RESTORED BY THE CONTRACTOR WITHIN FIVE DAYS AFTER NOTIFICATION FROM THE CITY INSPECTORS.
8. ALL FLAGGED ELEVATIONS SHALL BE STAKED IN THE FIELD BY THE PRIVATE ENGINEER.
9. THE CONTRACTOR SHALL CALL IN A LOCATIONS REQUEST TO UNDERGROUND SERVICE ALERT (USA), PHONE NO. 1-800-227-2800, TWO WORKING DAYS BEFORE DIGGING NO CONSTRUCTION PERMIT WILL BE ISSUED BY THE PUBLIC WORKS DEPARTMENT INVOLVING EXCAVATION FOR UNDERGROUND FACILITIES UNLESS THE APPLICANT HAS BEEN PROVIDED AN INQUIRY IDENTIFICATION NUMBER BY U.S.A.
10. THE DEVELOPER SHALL BE RESPONSIBLE FOR PRESERVING OR RE-ESTABLISHING AND REFERENCING SURVEY MONUMENTS DESTROYED, DISTURBED OR BURIED AS A RESULT OF CONSTRUCTION SHOWN HEREON.
11. NOTICE TO CONTRACTOR: THE EXISTENCE AND LOCATION OF ANY UNDERGROUND UTILITY PIPES OR STRUCTURES SHOWN ON THESE PLANS WERE OBTAINED BY A SEARCH OF AVAILABLE RECORDS. TO THE BEST OF OUR KNOWLEDGE THERE ARE NO EXISTING UTILITIES EXCEPT AS SHOWN ON THESE PLANS. THE CONTRACTOR IS REQUIRED TO TAKE PRECAUTIONARY MEASURES TO PROTECT THE UTILITY LINES SHOWN ON ANY OTHER LINES NOT OF RECORD OR NOT SHOWN ON THESE PLANS.
15. PRIOR TO CONSTRUCTION THE CONTRACTOR SHALL POTHOLE ALL UTILITY CROSSING AND CONNECTIONS AND VERIFY THE LOCATION AND ELEVATION OF ALL UTILITIES AFFECTED. THE ENGINEER SHALL BE NOTIFIED OF ANY DISCREPANCIES BEFORE CONSTRUCTION BEGINS.
16. NO PERSON SHALL PERFORM ANY CONSTRUCTION ACTIVITY OR INSTALL ANY OBJECTS WITHIN THE PUBLIC RIGHTS-OF-WAY OR EASEMENTS OF THE CITY OF RIVERSIDE WITHOUT A VALID CONSTRUCTION PERMIT OR, A STREET OPENING PERMIT OR AN ENCROACHMENT PERMIT ISSUED BY THE CITY'S PUBLIC WORKS DEPARTMENT.
17. ON ALL AREAS WITHIN PUBLIC RIGHT-OF-WAY WHERE THE FILL IS ONE (1) FOOT OR GREATER, A LETTER WILL BE REQUIRED FROM THE SOILS ENGINEER, CERTIFYING THE COMPACTION OF THE FILL BELOW SUBGRADE, PRIOR TO ISSUANCE OF THE CONSTRUCTION PERMIT/CUT SHEETS.

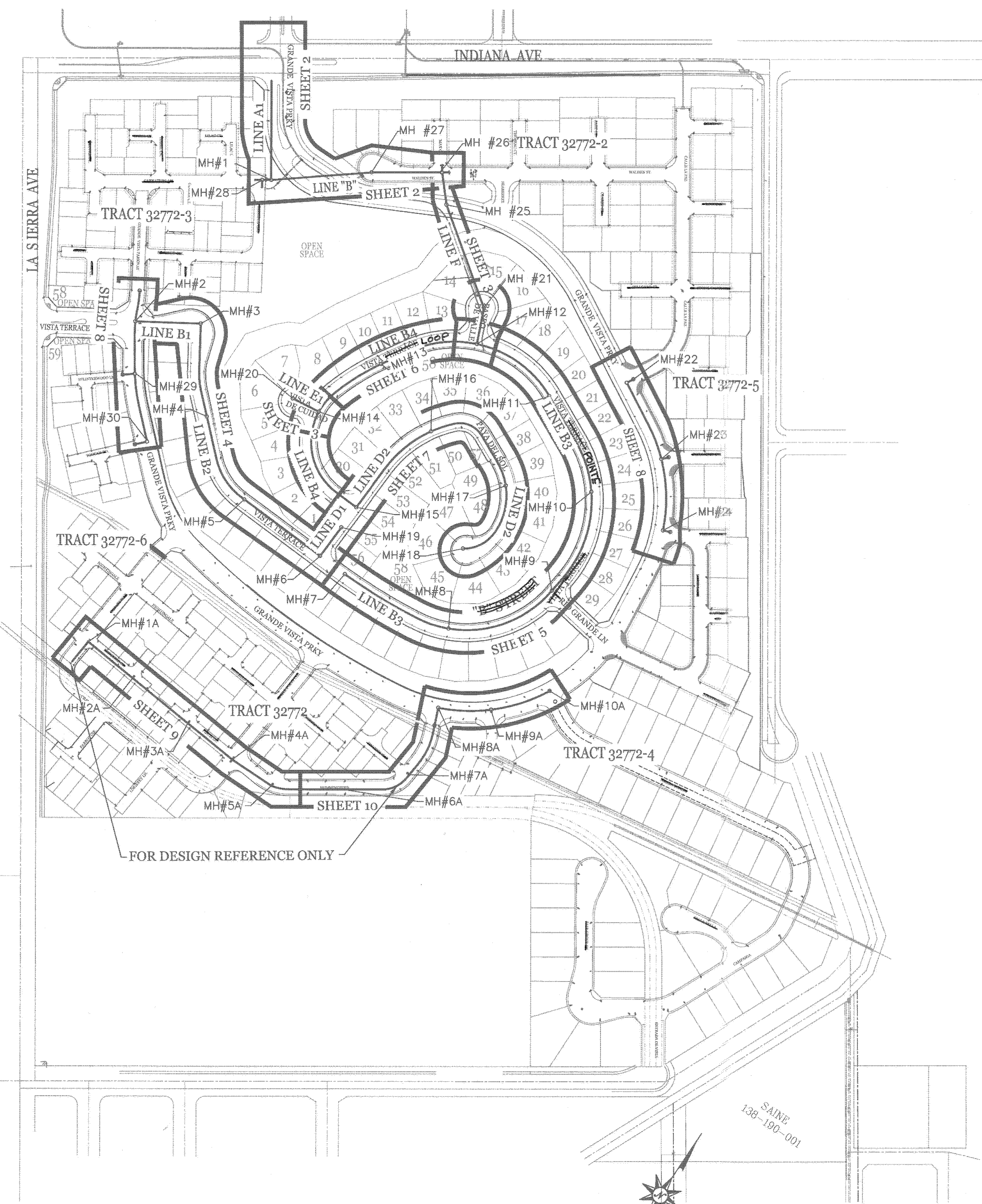
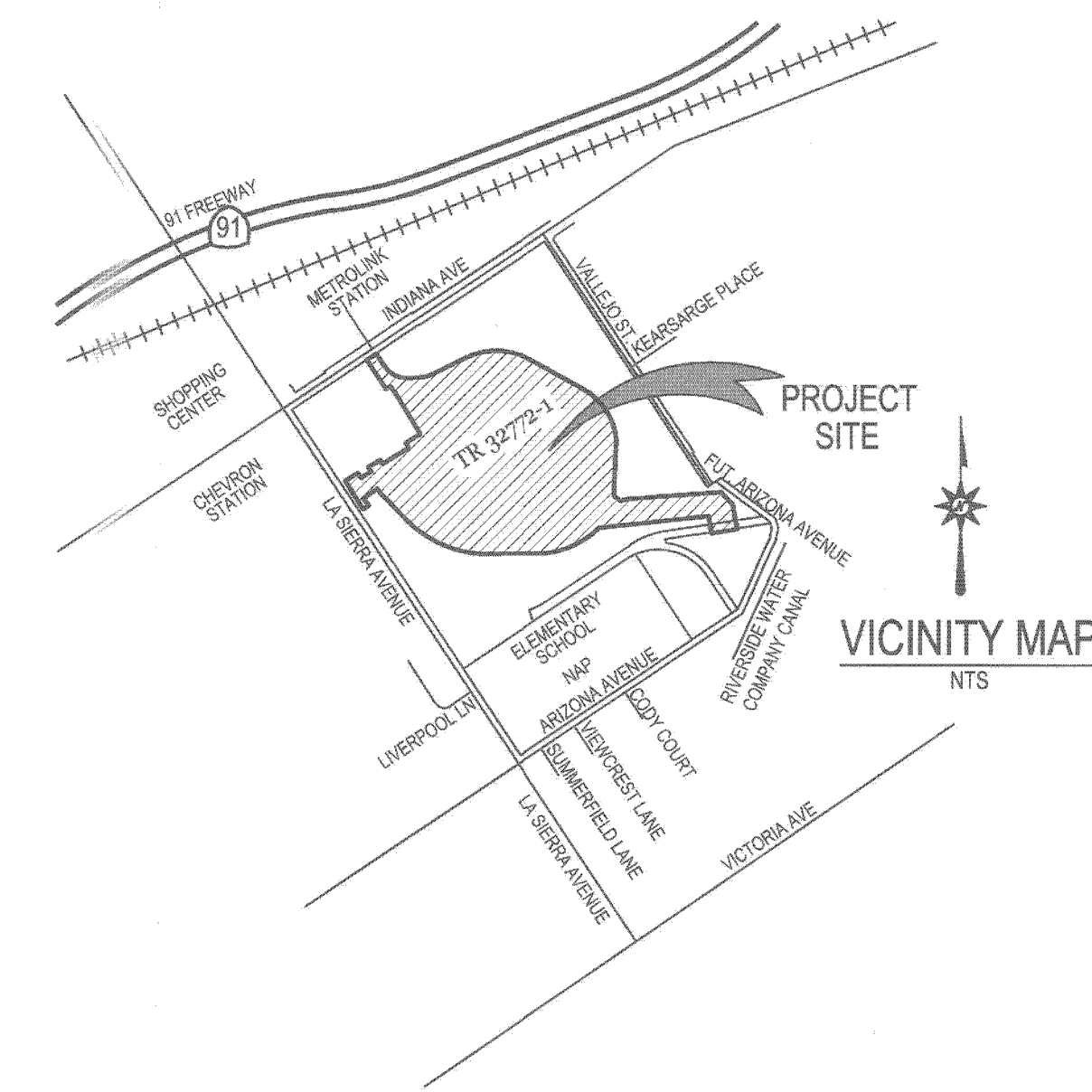

**LEGEND**

- PROPOSED 8" VCP SEWER MAIN
- PROPOSED SEWER MANHOLE
- PROPOSED SEWER CLEAN-OUT
- - - EXISTING SEWER LINE
- ⊙ EXISTING SEWER MANHOLE
- \* 4" BACKWATER VALVE
- SEWER LATERAL
- SHEET X SHEET NUMBER
- - - - - TRACT BOUNDARY

**CONSTRUCTION NOTES**

- |  | QNTY  | UNITS |
|--|-------|-------|
| ① CONSTRUCT 8" VCP SEWER MAIN  | 4,430 | LF    |
| ② CONSTRUCT 8" DRY VCP SEWER MAIN  | 2,225 | LF    |
| ③ CONSTRUCT 48" SEWER MANHOLE PER CITY OF RIV. STD. DWG No. 500          | 29    | EA    |
| ④ CONSTRUCT 60" SEWER MANHOLE PER CITY OF RIV. STD. DWG No. 500          | 1     | EA    |
| ⑤ INSTALL TEMP. SEWER CLEAN-OUT PER CITY OF RIV. STD. DWG No. 560        | 4     | EA    |
| ⑥ INSTALL TEMP. 8" END PLUG  | 16    | EA    |
| ⑦ REMOVE 8" END PLUG AND JOIN  | 1     | EA    |
| ⑧ CONSTRUCT 4" SEWER LATERAL W/CLEANOUT PER CITY RIV. STD. DWG. No. 562A | 2580  | LF    |
| ⑨ INSTALL 4" BACKWATER VALVE   | 25    | EA    |
| ⑩ INSTALL 48" DRY SEWER MANHOLE PER CITY OF RIV. STD. DWG No. 500        | 5     | EA    |
- ALL RIMS TO BE PAVED OVER TO RESTRICT ACCESS.

PUBLIC UTILITIES DEPARTMENT  
WATER DIVISION

APPROVED BY: *MW McRed* DATE: 11/30/06

Underground Service Alert  
Call: TOLL FREE  
1 - 800  
227-2600  
TWO WORKING DAYS BEFORE YOU DIG

**PRIVATE ENGINEERING NOTE**

CONSTRUCTION CONTRACTOR AGREES THAT IN ACCORDANCE WITH GENERALLY ACCEPTED CONSTRUCTION PRACTICES, CONSTRUCTION CONTRACTOR WILL BE REQUIRED TO ASSUME SOLE AND COMPLETE RESPONSIBILITY FOR JOB SITE CONDITIONS DURING THE COURSE OF CONSTRUCTION OF THE PROJECT, INCLUDING SAFETY OF ALL PERSONS AND PROPERTY, THAT THE REQUIREMENT SHALL BE MADE TO APPLY CONTINUOUSLY AND NOT BE LIMITED TO NORMAL WORKING HOURS, AND CONSTRUCTION CONTRACTOR FURTHER AGREES TO DEFEND, INDEMNIFY AND HOLD DESIGN PROFESSIONAL HARMLESS FROM ANY AND ALL LIABILITY, REAL OR ALLEGED, IN CONNECTION WITH THE PERFORMANCE OF WORK ON THIS PROJECT, EXCEPTING LIABILITY ARISING FROM THE SOLE NEGLIGENCE OF DESIGN PROFESSIONAL.

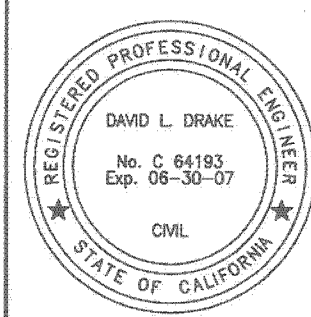

PREPARED UNDER THE DIRECTION OF:  
*[Signature]*  
REGISTERED CIVIL ENGINEER NO. C 64193  
EXPIRATION DATE: 06-30-07 DATE: 11/30/06

PLANS PREPARED BY:  
**PSOMAS**  
2010 Iowa Avenue Suite 101 Riverside, CA 92507  
(951) 787-8421 Fax (951) 682-3379  
CITY OF RIVERSIDE TAX CERT NO: 69372 EXP: 4-07-07  
SCALE: AS SHOWN  
BENCH MARK: F2-P2 CHISELED SQUARE ON THE TOP OF CURB AT THE WESTERLY END OF A CATCH BASIN FRONTING THE SOUTHERLY CURB OF INDIANA AVE. AT THE SOUTHEAST CORNER OF INDIANA AVENUE AND FILLMORE STREET. ELEV=738.410  
DATE: FEBRUARY 2006

MARK REVISIONS APPR. DATE  
DESIGNED BY: DD DRAWN BY: CA CHECKED BY:

CITY OF RIVERSIDE, CALIFORNIA  
DEPARTMENT OF PUBLIC WORKS

APPROVED BY: *[Signature]*  
PRINCIPAL ENGR.

APPROVED BY: *[Signature]*  
CITY ENGINEER

DATE: 11/30/06

IN THE CITY OF RIVERSIDE, CALIFORNIA  
TRACT 32772-1  
SEWER IMPROVEMENT PLAN

**TITLE SHEET**

FOR: GRIFFIN INDUSTRIES

PW06-0329

S-2002

SHEET 1 OF 10

FILE NO.: 1104-007

WDID: 8 33C334294

INDEXED 2-5-07

S2002-1

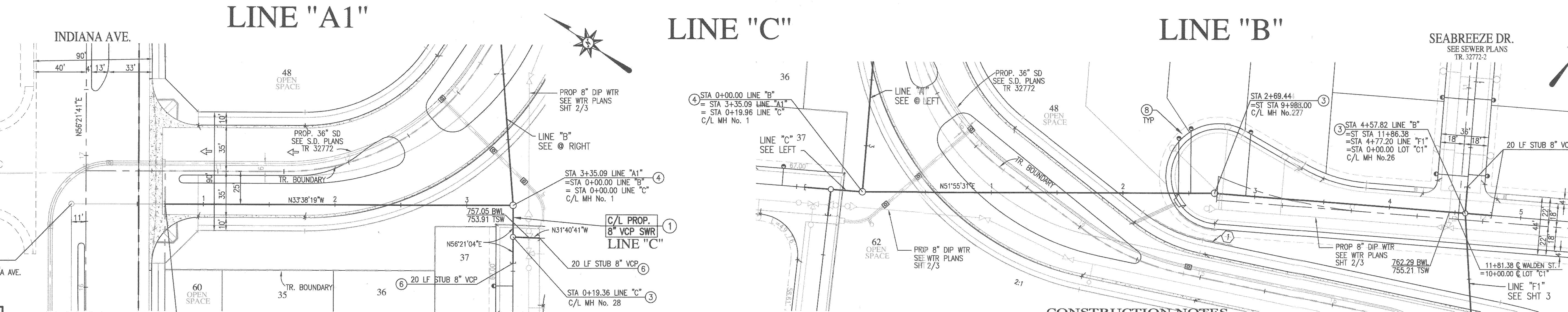
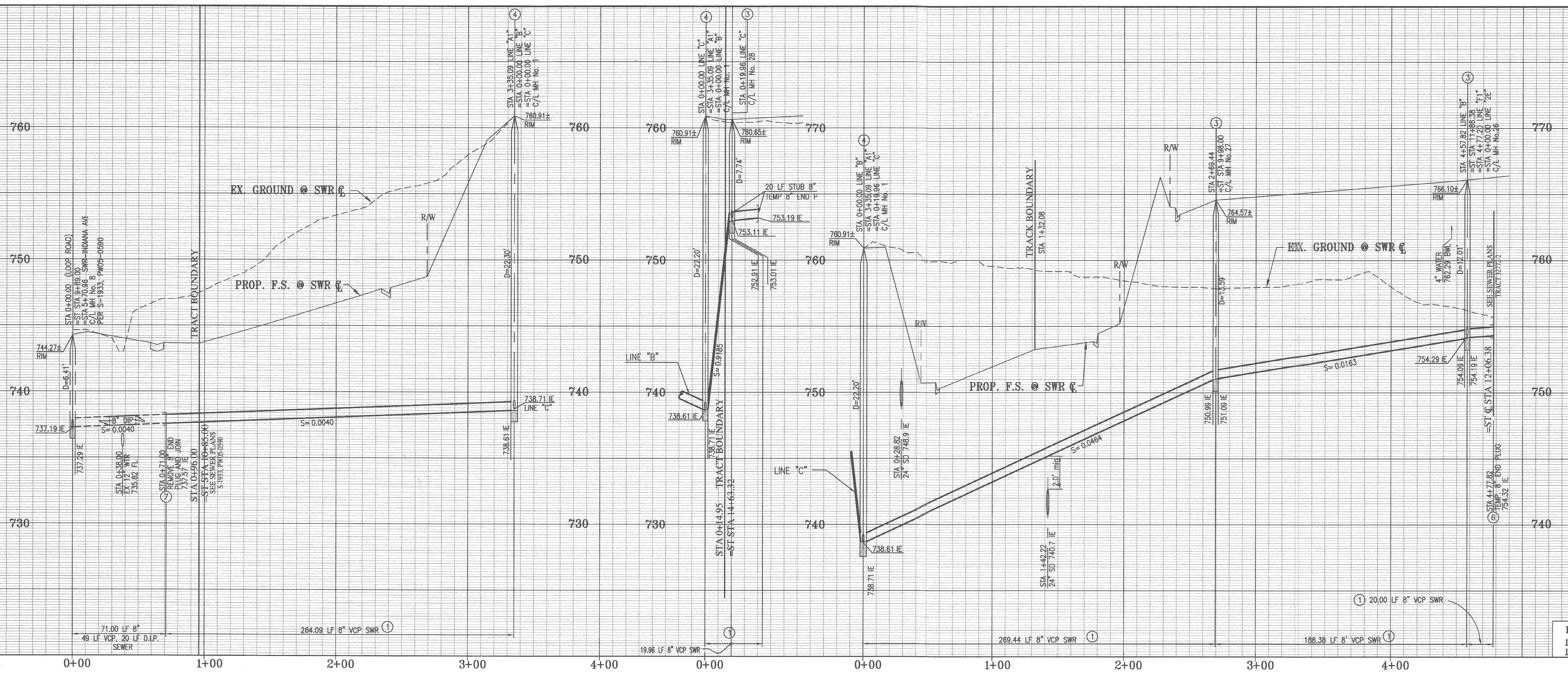

- CONSTRUCTION NOTES**
- 1) CONSTRUCT 8" VCP SEWER MAIN W/ PIPE BODDAG I PERFORM STD. DWG NO. 452
  - 2) CONSTRUCT 48" SEWER MANHOLE PER CITY OF RIV. STD. DWG No. 500.
  - 3) CONSTRUCT 60" SEWER MANHOLE PER CITY OF RIV. STD. DWG No. 500.
  - 4) INSTALL TEMP. 8" END PLUG
  - 5) REMOVE 8" END PLUG AND JOIN
  - 6) CONSTRUCT 4" SEWER LATERAL W/CLEANOUT PER CITY RIV. STD. DWG. No. 562A

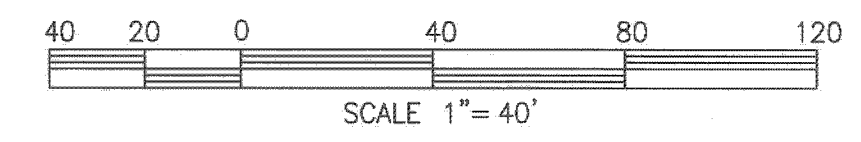

PUBLIC UTILITIES DEPARTMENT  
WATER DIVISION

APPROVED BY: *MW MCL* DATE: 11/30/06

Underground Service Alert  
Call: TOLL FREE  
1 - 800  
227-2600  
TWO WORKING DAYS BEFORE YOU DIG

PRIVATE ENGINEERING NOTE

CONSTRUCTION CONTRACTOR AGREES THAT IN ACCORDANCE WITH GENERALLY ACCEPTED CONSTRUCTION PRACTICES, CONSTRUCTION CONTRACTOR WILL BE REQUIRED TO ASSUME SOLE AND COMPLETE RESPONSIBILITY FOR JOB SITE CONDITIONS DURING THE COURSE OF CONSTRUCTION OF THE PROJECT, INCLUDING SAFETY OF ALL PERSONS AND PROPERTY; THAT THIS REQUIREMENT SHALL BE MADE TO APPLY CONTINUOUSLY AND NOT BE LIMITED TO NORMAL WORKING HOURS; AND CONSTRUCTION CONTRACTOR FURTHER AGREES TO DEFEND, INDEMNIFY AND HOLD DESIGN PROFESSIONAL HARMLESS FROM ANY AND ALL LIABILITY, REAL OR ALLEGED, IN CONNECTION WITH THE PERFORMANCE OF WORK ON THIS PROJECT, EXCEPTING LIABILITY ARISING FROM THE SOLE NEGLIGENCE OF DESIGN PROFESSIONAL.

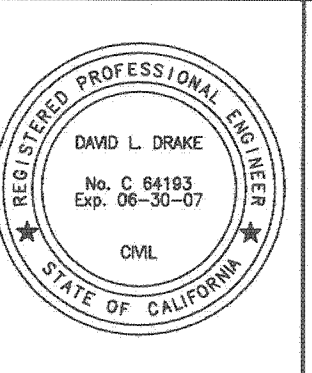

PREPARED UNDER THE DIRECTION OF:

PLANS PREPARED BY:

**PSOMAS**

2010 Iowa Avenue Suite 101 Riverside, CA 92507  
(951) 787-8421 Fax (951) 882-3379  
CITY OF RIVERSIDE TAX CERT NO: 69372 EXP: 4-07-07

SCALE: AS SHOWN BENCH MARK: E2-P2 CHISELED SQUARE ON THE TOP OF CURB AT THE WESTERLY END OF A CATCH BASIN FRONTING THE SOUTHERLY CURB OF INDIANA AVE. AT THE SOUTHEAST CORNER OF INDIANA AVENUE AND FILLMORE STREET. ELEV=738.410

REGISTERED CIVIL ENGINEER NO. C 84183  
EXPIRATION DATE: 06-30-07 DATE: 11/20/06

CITY OF RIVERSIDE, CALIFORNIA  
DEPARTMENT OF PUBLIC WORKS

APPROVED BY: *[Signature]* DATE: *[Date]*  
PRINCIPAL ENGR.

IN THE CITY OF RIVERSIDE, CALIFORNIA  
TRACT 32772-1  
SEWER IMPROVEMENT PLAN  
LINE "A1"  
LINE "C"  
LINE "B"

STA 00+00.00 TO STA 3+35.09  
STA 00+00.00 TO STA 0+19.96  
STA 00+00.00 TO STA 4+57.82

FOR: GRIFFIN INDUSTRIES

PW06-0329  
S-2002  
SHEET 2 OF 10  
FILE NO.: 1104-007

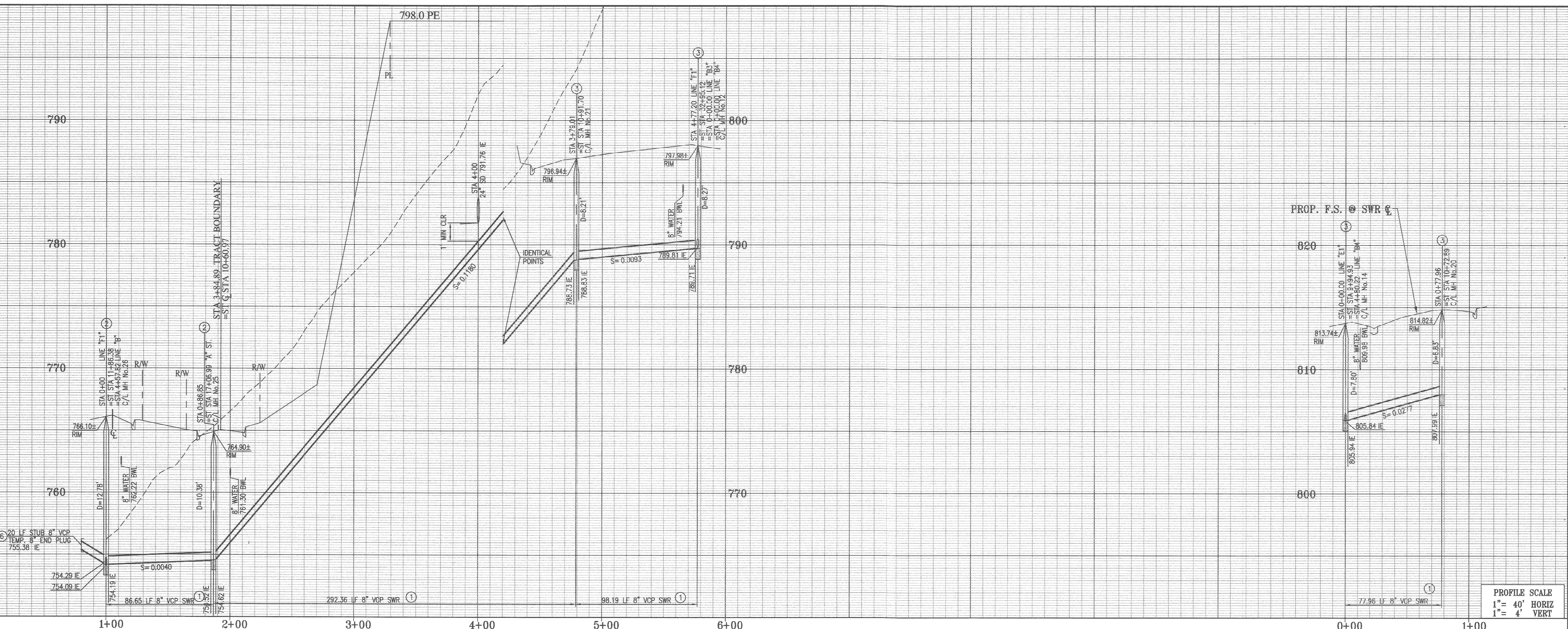

LINE "F1"

LINE "E1"

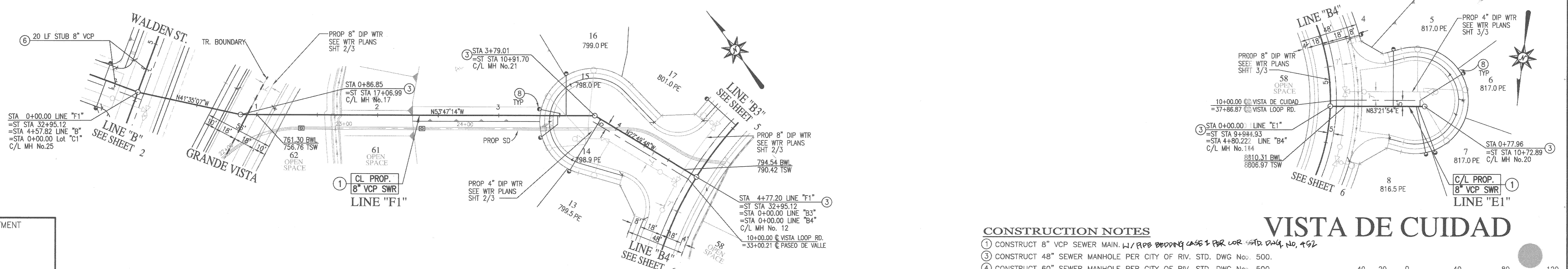

PASEO DE VALLE

VISTA DE CUIDAD

CONSTRUCTION NOTES

- ① CONSTRUCT 8" VCP SEWER MAIN, 1/1' PROP BEDDING CASE 2 PER COR STD DWG. NO. 492
- ② CONSTRUCT 48" SEWER MANHOLE PER CITY OF RIV. STD. DWG No. 500.
- ③ CONSTRUCT 60" SEWER MANHOLE PER CITY OF RIV. STD. DWG No. 500.
- ④ INSTALL TEMP. 8" END PLUG
- ⑤ CONSTRUCT 4" SEWER LATERAL W/CLEANOUT PER CITY RIV. STD. DWG. No. 562A

PUBLIC UTILITIES DEPARTMENT  
WATER DIVISION

MW McLeod 11/30/06  
APPROVED BY DATE

PRIVATE ENGINEERING NOTE

CONSTRUCTION CONTRACTOR AGREES THAT IN ACCORDANCE WITH GENERALLY ACCEPTED CONSTRUCTION PRACTICES, CONSTRUCTION CONTRACTOR WILL BE REQUIRED TO ASSUME SOLE AND COMPLETE RESPONSIBILITY FOR JOB SITE CONDITIONS DURING THE COURSE OF CONSTRUCTION OF THE PROJECT, INCLUDING SAFETY OF ALL PERSONS AND PROPERTY; THAT THIS REQUIREMENT SHALL BE MADE TO APPLY CONTINUOUSLY AND NOT BE LIMITED TO NORMAL WORKING HOURS; AND CONSTRUCTION CONTRACTOR FURTHER AGREES TO DEFEND, INDEMNIFY AND HOLD DESIGN PROFESSIONAL HARMLESS FROM ANY AND ALL LIABILITY, REAL OR ALLEGED, IN CONNECTION WITH THE PERFORMANCE OF WORK ON THIS PROJECT, EXCEPTING LIABILITY ARISING FROM THE SOLE NEGLIGENCE OF DESIGN PROFESSIONAL.

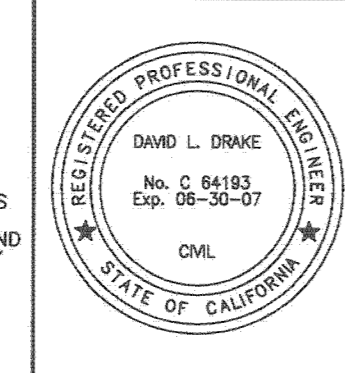

PREPARED UNDER THE DIRECTION OF:

PLANS PREPARED BY:

**PSOMAS**

2010 Iowa Avenue Suite 101 Riverside, CA 92507  
(951) 787-8421 Fax (951) 682-3379  
CITY OF RIVERSIDE TAX CERT NO: 69372 EXP: 4-07-07

SCALE: AS SHOWN BENCH MARK: E2-P2 CHISELED SQUARE ON THE TOP OF CURB AT THE WESTERLY END OF A CATCH BASIN FRONTING THE SOUTHERLY CURB OF INDIANA AVE. AT THE SOUTHEAST CORNER OF INDIANA AVENUE AND FILLMORE STREET. ELEV=738.410

REGISTERED CIVIL ENGINEER NO. C 64193  
EXPIRATION DATE: 06-30-07 DATE: 11/20/06

MARK	REVISIONS	APPR.	DATE

DESIGNED BY: DD DRAWN BY: CA CHECKED BY: \_\_\_\_\_

CITY OF RIVERSIDE, CALIFORNIA  
DEPARTMENT OF PUBLIC WORKS

APPROVED BY: \_\_\_\_\_ DATE: \_\_\_\_\_  
PRINCIPAL ENGR.

APPROVED BY: \_\_\_\_\_ DATE: 11/29/06  
CITY ENGINEER

IN THE CITY OF RIVERSIDE, CALIFORNIA  
TRACT 32772-1  
SEWER IMPROVEMENT PLAN

LINE "F1" STA 00+00.00 TO STA 4+77.20  
LINE "E1" STA 00+00.00 TO STA 0+77.96

FOR: GRIFFIN INDUSTRIES

PW06-0329  
S-2002  
SHEET 3 OF 10  
FILE NO.: 1104-007

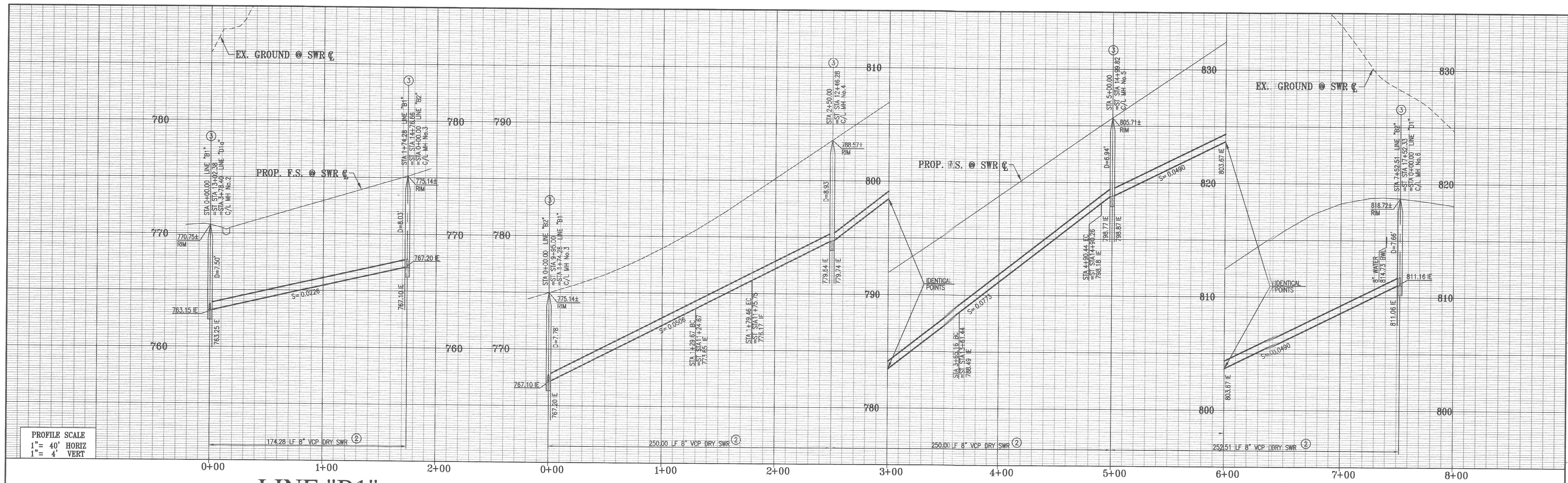

PROFILE SCALE  
1" = 40' HORIZ  
1" = 4' VERT

LINE "B1"

LINE "B2"

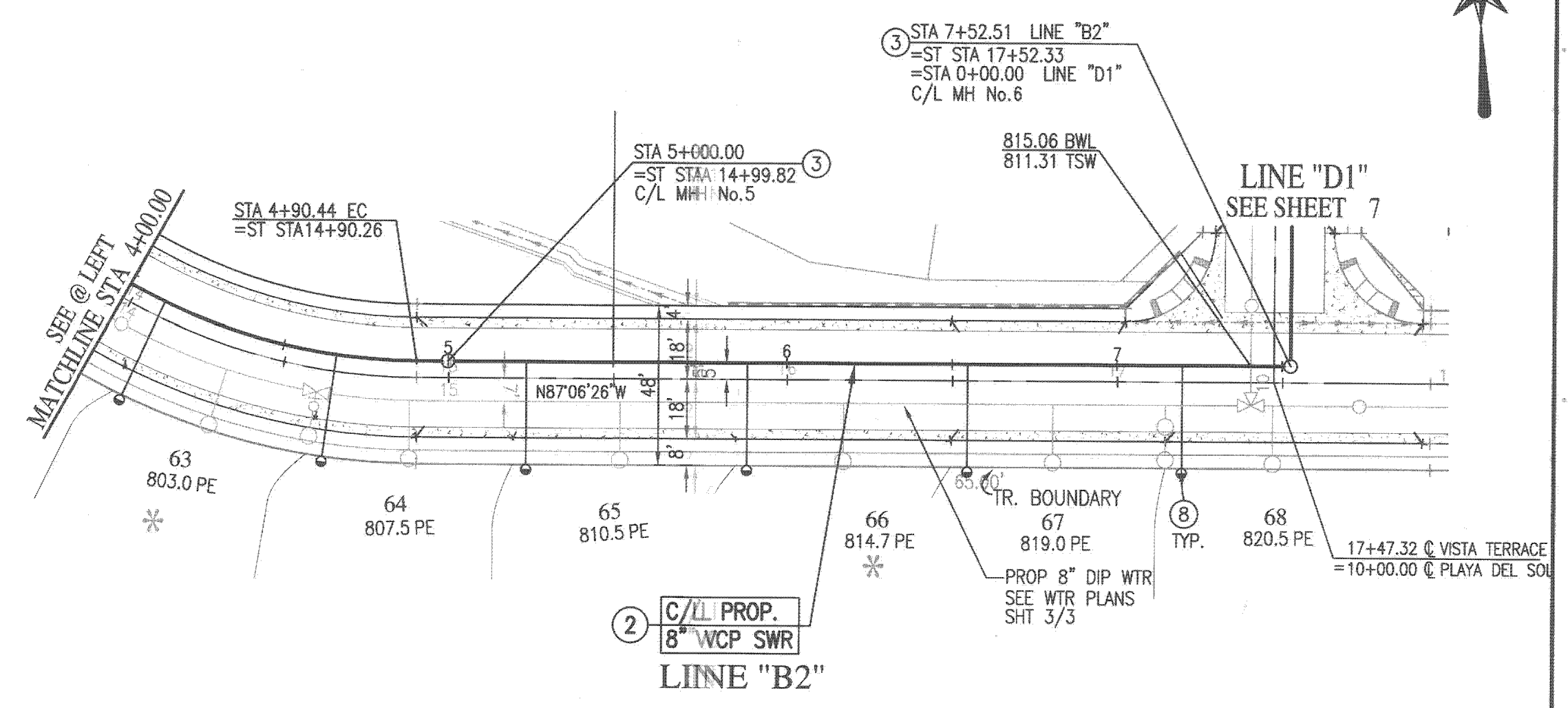
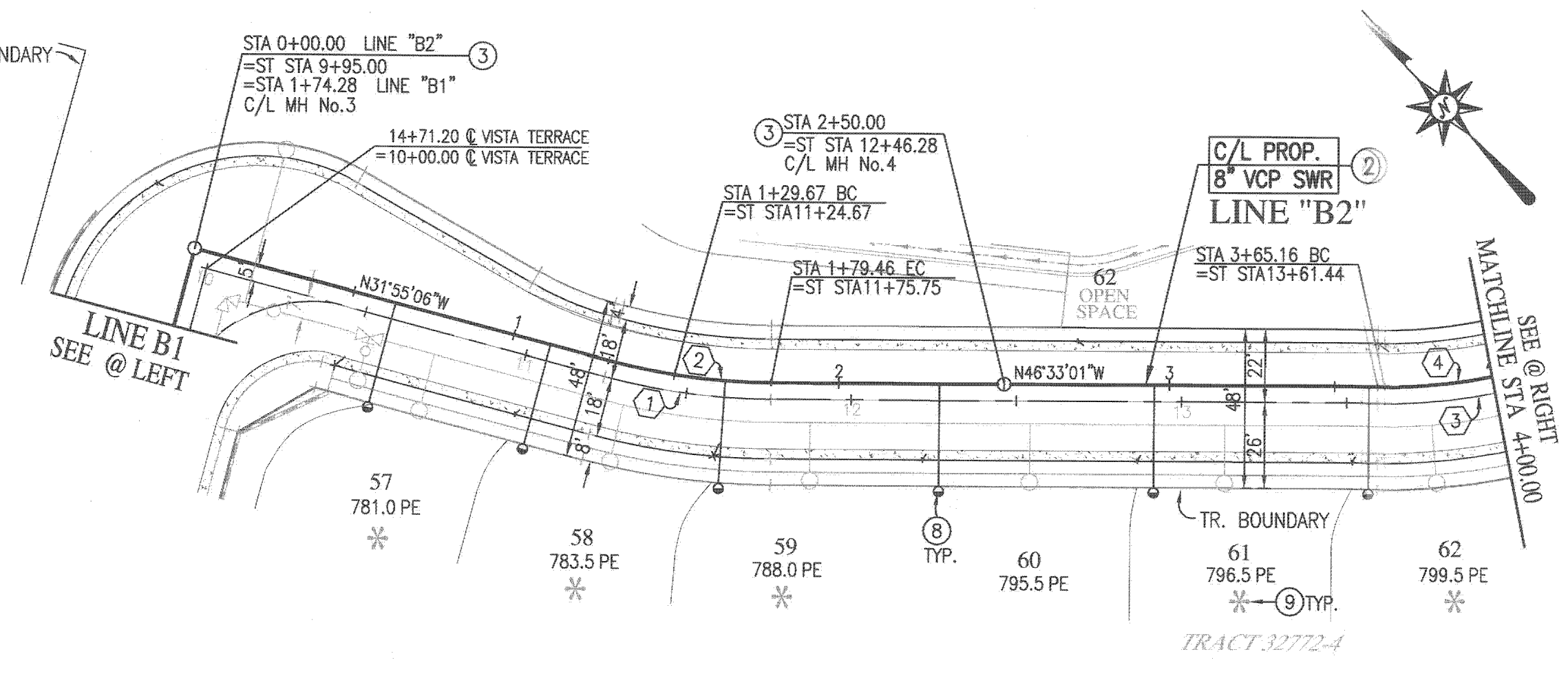
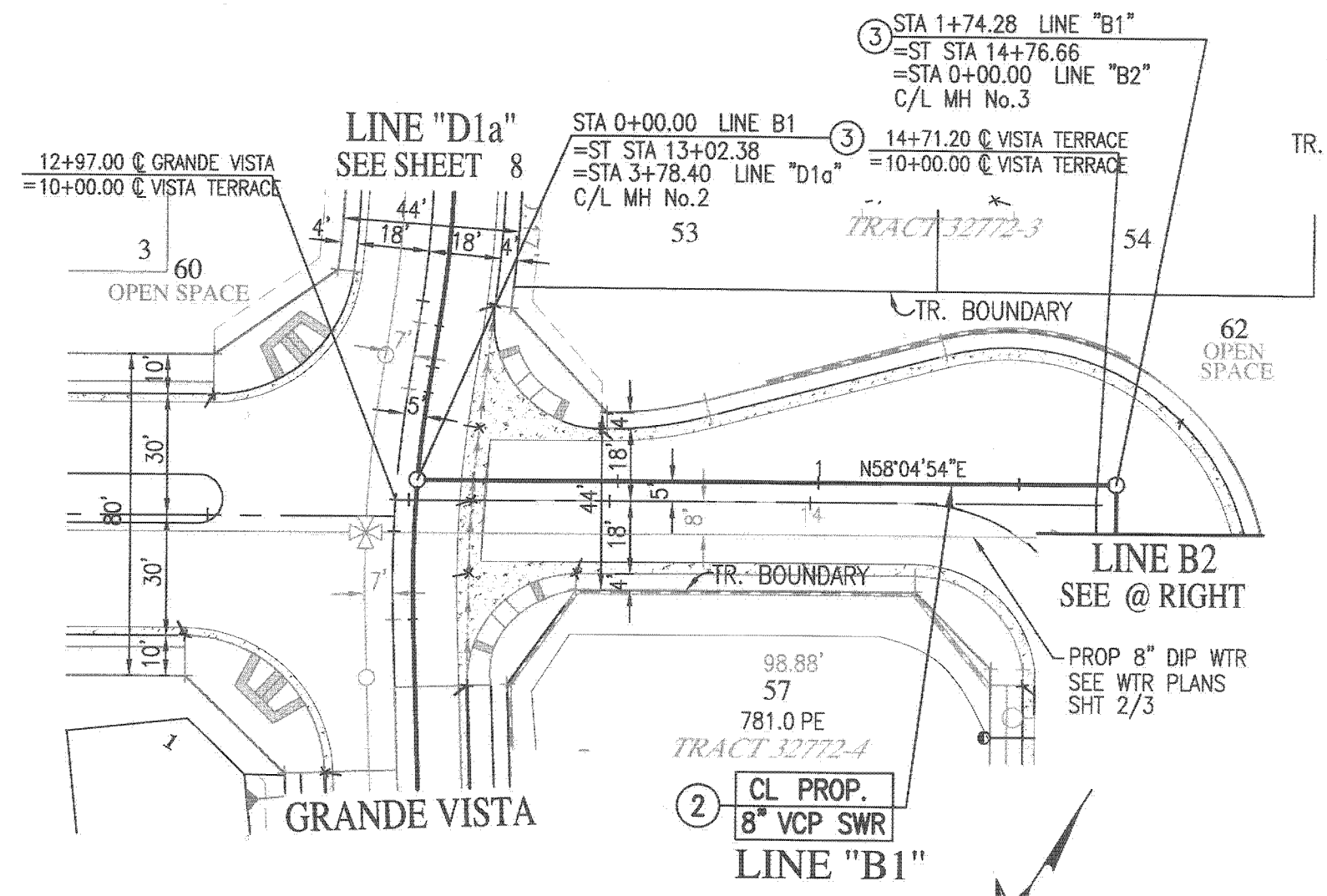

CURVE DATA

No.	DELTA	RADIUS	LENGTH	TANGENT
①	14°38'06"	200.00'	51.09'	25.68'
②	14°38'07"	195.00'	49.81'	25.04'
③	40°33'14"	182.00'	128.82'	67.24'
④	40°33'14"	177.00'	125.28'	65.39'

CONSTRUCTION NOTES

- ② CONSTRUCT 8" DRY VCP SEWER MAIN W/ PIPE BEDDING CASE 3 PER COR. STD. DWG. NO. 452
- ③ CONSTRUCT 48" SEWER MANHOLE PER CITY OF RIV. STD. DWG. NO. 500
- ⑧ CONSTRUCT 4" SEWER LATERAL W/CLEANOUT PER CITY RIV. STD. DWG. NO. 562A
- ⑨ INSTALL 4" BACKWATER VALVE

VISTA TERRACE

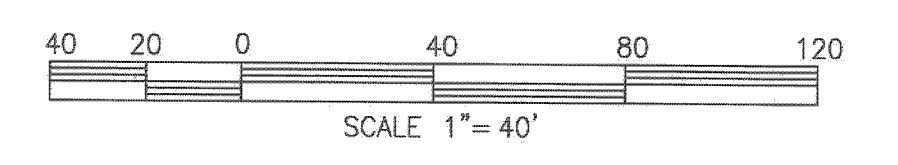

PUBLIC UTILITIES DEPARTMENT  
WATER DIVISION  
  
MW MCL  
11/30/06  
APPROVED BY DATE

PRIVATE ENGINEERING NOTE

CONSTRUCTION CONTRACTOR AGREES THAT IN ACCORDANCE WITH GENERALLY ACCEPTED CONSTRUCTION PRACTICES, CONSTRUCTION CONTRACTOR WILL BE REQUIRED TO ASSUME SOLE AND COMPLETE RESPONSIBILITY FOR JOB SITE CONDITIONS DURING THE COURSE OF CONSTRUCTION OF THE PROJECT, INCLUDING SAFETY OF ALL PERSONS AND PROPERTY; THAT THIS REQUIREMENT SHALL BE MADE TO APPLY CONTINUOUSLY AND NOT BE LIMITED TO NORMAL WORKING HOURS; AND CONSTRUCTION CONTRACTOR FURTHER AGREES TO DEFEND, INDEMNIFY AND HOLD DESIGN PROFESSIONAL HARMLESS FROM ANY AND ALL LIABILITY, REAL OR ALLEGED, IN CONNECTION WITH THE PERFORMANCE OF WORK ON THIS PROJECT EXCEPT LIABILITY ARISING FROM THE SOLE NEGLIGENCE OF DESIGN PROFESSIONAL.

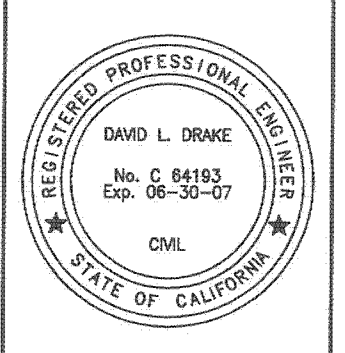

PREPARED UNDER THE DIRECTION OF:  
*[Signature]*  
REGISTERED CIVIL ENGINEER NO. C 64193  
EXPIRATION DATE: 06-30-07 DATE: 11/30/06

PLANS PREPARED BY:  
**PSOMAS**  
2010 Iowa Avenue Suite 101 Riverside, CA 92507  
(951) 787-8421 Fax (951) 682-3379  
CITY OF RIVERSIDE TAX CERT NO: 69372 EXP: 4-07-07  
SCALE: AS SHOWN  
BENCH MARK: E2-P2 CHISELED SQUARE ON THE TOP OF CURB AT THE WESTERLY END OF A CATCH BASIN FRONTING THE SOUTHERLY CURB OF INDIANA AVE. AT THE SOUTHEAST CORNER OF INDIANA AVENUE AND FILLMORE STREET. ELEV=738.410  
DATE: FEBRUARY 2006

MARK	REVISIONS	APPR.	DATE

CITY OF RIVERSIDE, CALIFORNIA  
DEPARTMENT OF PUBLIC WORKS  
APPROVED BY: *[Signature]*  
PRINCIPAL ENGR.  
DATE: 11/30/06

IN THE CITY OF RIVERSIDE, CALIFORNIA  
TRACT 32772-1  
SEWER IMPROVEMENT PLAN  
LINE "B1" STA 00+00.00 TO STA 1+74.28  
LINE "B2" STA 00+00.00 TO STA 7+52.51  
FOR: GRIFFIN INDUSTRIES  
PW06-0329  
S-2002  
SHEET 4 OF 10  
FILE NO.: 1104-007

WDID: 8 33C334294

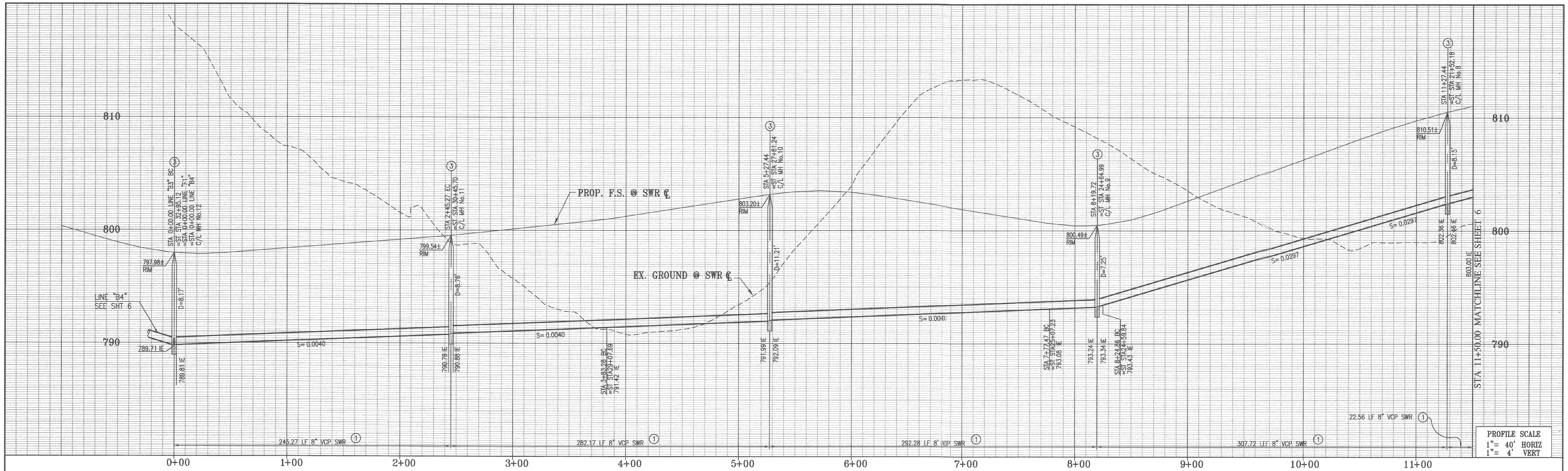

**LINE "B3"**

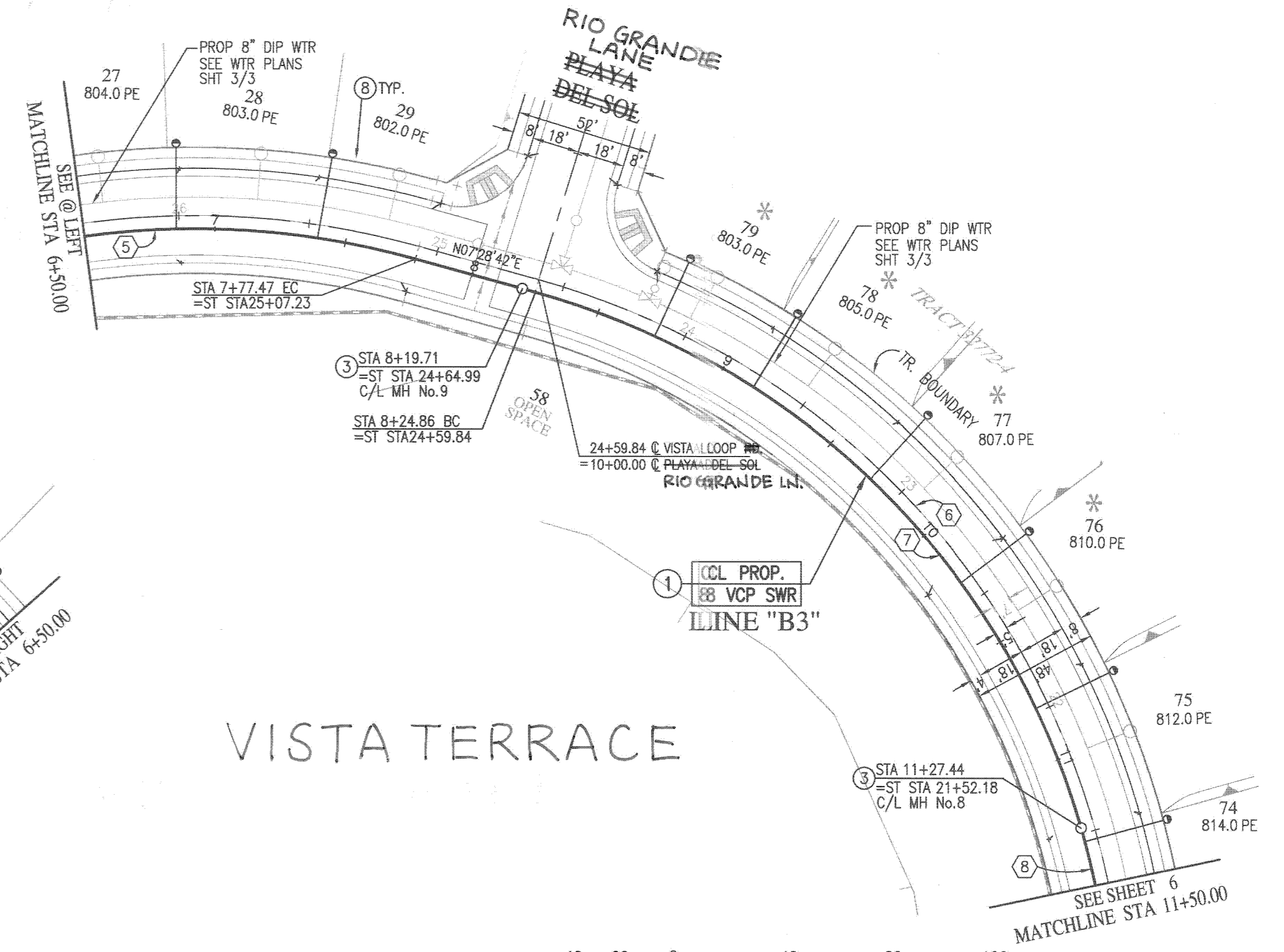
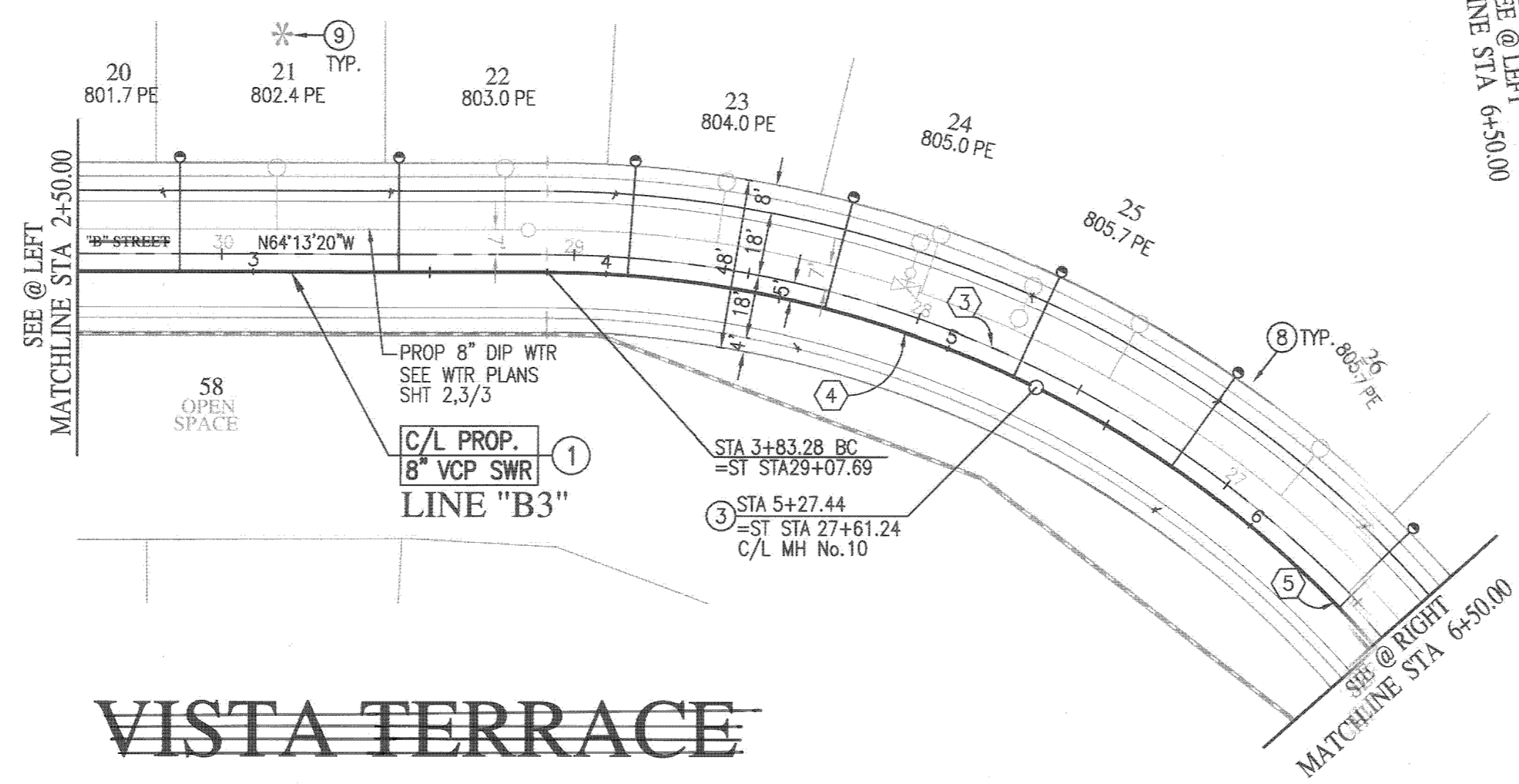
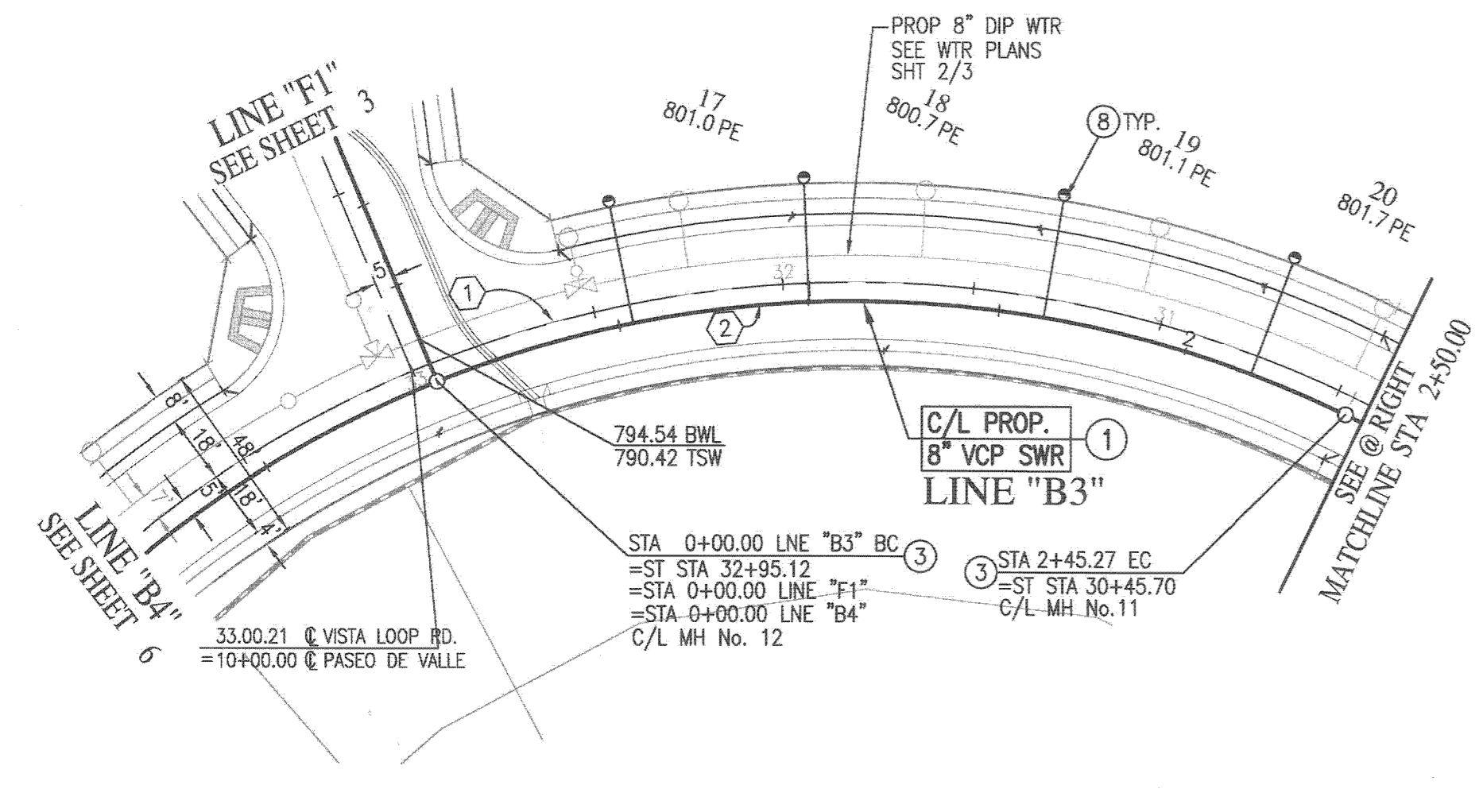

**CURVE DATA**

No.	DELTA	RADIUS	LENGTH	TANGENT
①	47°38'12"	300.00'	249.42'	132.43'
②	46°51'35"	295.00'	241.27'	127.84'
③	71°42'02"	320.00'	400.45'	231.22'
④	25°51'27"	315.00'	142.16'	72.31'
⑤	45°06'56"	315.00'	248.04'	130.85'
⑥	62°43'26"	302.00'	330.61'	184.07'
⑦	57°59'07"	297.00'	300.57'	164.58'
⑧	3°58'01"	297.00'	20.56'	10.29'

**VISTA TERRACE  
VISTA POINTE**

- CONSTRUCTION NOTES**
- ① CONSTRUCT 8" VCP SEWER MAIN. 1/1 PIPE DEPTH CASE 1 PER COR. TO REG. NO. 452
  - ② CONSTRUCT 48" SEWER MANHOLE PER CITY OF RIV. STD. DWG. No. 500.
  - ③ CONSTRUCT 4" SEWER LATERAL W/CLEANOUT PER CITY RIV. STD. DWG. No. 562A
  - ④ CONSTRUCT 4" BACKWATER VALVE

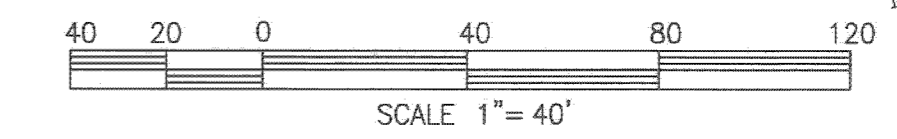

PUBLIC UTILITIES DEPARTMENT  
WATER DIVISION

*MW MORA* 11/30/02  
APPROVED BY DATE

Underground Service Alert  
Call: TOLL FREE  
1 - 800  
227-2600  
TWO WORKING DAYS BEFORE YOU DIG

PRIVATE ENGINEERING NOTE

CONSTRUCTION CONTRACTOR AGREES THAT IN ACCORDANCE WITH GENERALLY ACCEPTED CONSTRUCTION PRACTICES, CONSTRUCTION CONTRACTOR WILL BE REQUIRED TO ASSUME SOLE AND COMPLETE RESPONSIBILITY FOR JOB SITE CONDITIONS DURING THE COURSE OF CONSTRUCTION OF THE PROJECT, INCLUDING SAFETY OF ALL PERSONS AND PROPERTY; THAT THIS REQUIREMENT SHALL BE MADE TO APPLY CONTINUOUSLY AND NOT BE LIMITED TO NORMAL WORKING HOURS, AND LIABILITY, REAL OR ALLEGED, IN CONNECTION WITH THE PERFORMANCE OF WORK ON THIS PROJECT EXCEPTING LIABILITY ARISING FROM THE SOLE NEGLIGENCE OF DESIGN PROFESSIONAL.

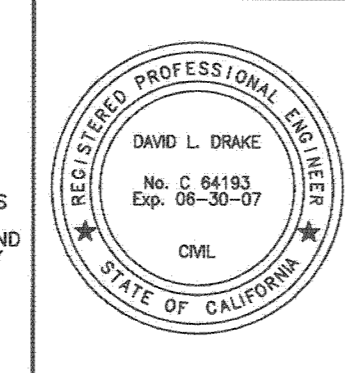

PREPARED UNDER THE DIRECTION OF:  
*David Drake*  
REGISTERED CIVIL ENGINEER No. C 64193  
EXPIRATION DATE: 06-30-07 DATE: 11/20/02

PLANS PREPARED BY:  
**PSOMAS**  
2010 Iowa Avenue Suite 101 Riverside, CA 92507  
(951) 787-8421 Fax (951) 682-3379  
CITY OF RIVERSIDE TAX CERT NO: 69372 EXP: 4-07-07  
SCALE: AS SHOWN  
BENCH MARK: E2-P2 CHISELED SQUARE ON THE TOP OF CURBS AT THE WESTERLY END OF A CATCH BASIN FRONTING THE SOUTHERLY CURB OF INDIANA AVE. AT THE SOUTHEAST CORNER OF INDIANA AVENUE AND FILLMORE STREET. ELEV=738.410  
DATE: FEBRUARY 2006

MARK	REVISIONS	APPR. DATE

DESIGNED BY: DD DRAWN BY: CA CHECKED BY: \_\_\_\_\_

CITY OF RIVERSIDE, CALIFORNIA  
DEPARTMENT OF PUBLIC WORKS

APPROVED BY: \_\_\_\_\_ BY: \_\_\_\_\_ DATE: \_\_\_\_\_  
PRINCIPAL ENGR.

APPROVED BY: *David Drake*  
CITY ENGINEER  
DATE: 11/20/02

IN THE CITY OF RIVERSIDE, CALIFORNIA  
TRACT 32772-1  
SEWER IMPROVEMENT PLAN  
**LINE "B3"**  
STA 0+00.00 TO STA 11+50.00  
FOR: GRIFFIN INDUSTRIES

PW06-0329  
S-2002  
SHEET 5 OF 10  
FILE NO.: 1104-007

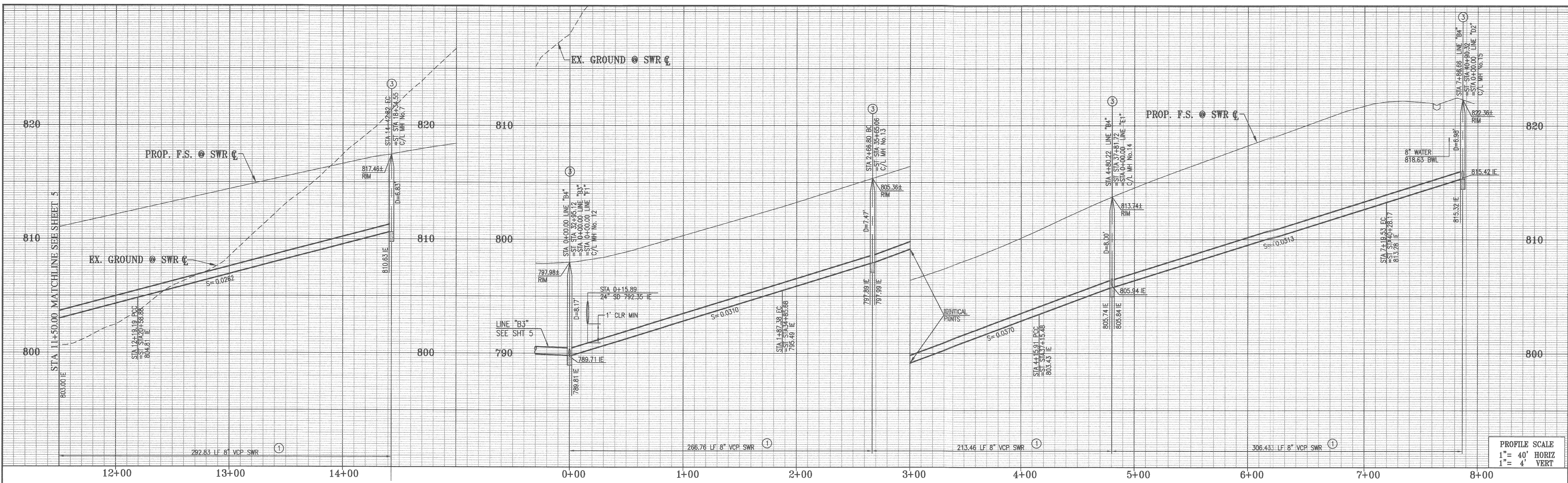

PROFILE SCALE  
1" = 40' HORIZ  
1" = 4' VERT

LINE "B3"

LINE "B4"

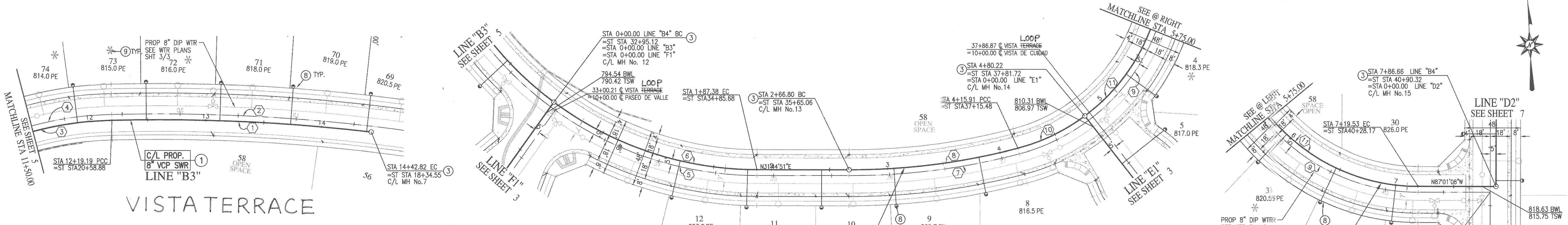

VISTA TERRACE

VISTA LOOP

VISTA TERRACE

VISTA LOOP

**CURVE DATA**

No.	DELTA	RADIUS	LENGTH	TANGENT
①	75°14'7"	1615.00'	221.64'	110.99'
②	7°56'02"	1620.00'	224.33'	112.34'
③	13°20'52"	297.00'	69.19'	34.75'
④	13°20'52"	302.00'	70.35'	35.34'
⑤	36°22'39"	300.00'	190.47'	98.57'
⑥	36°00'19"	295.00'	185.38'	95.87'
⑦	14°36'27"	590.00'	150.42'	75.62'
⑧	14°24'42"	585.00'	147.14'	73.96'
⑨	104°09'32"	172.00'	312.68'	220.78'
⑩	21°22'43"	167.00'	62.31'	31.52'
⑪	81°24'35"	167.00'	237.29'	143.67'

- CONSTRUCTION NOTES**
- CONSTRUCT 8" VCP SEWER MAIN. 1/4" OPEN BOTTOM CASE 2 PER COR TO CRY. NO. 451
  - CONSTRUCT 48" SEWER MANHOLE PER CITY OF RIV. STD. DWG. No. 500.
  - CONSTRUCT 4" SEWER LATERAL W/CLEANOUT PER CITY RIV. STD. DWG. No. 562A
  - INSTALL 4" BACKWATER VALVE

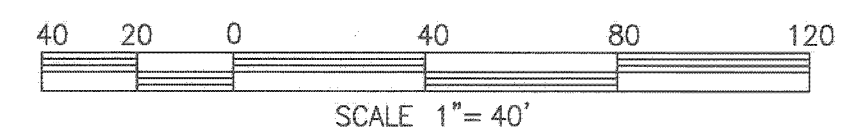

PUBLIC UTILITIES DEPARTMENT  
WATER DIVISION

Approved By: *MW Mad* DATE: 11/30/06

Underground Service Alert  
Call: TOLL FREE  
1 - 800  
227-2600  
TWO WORKING DAYS BEFORE YOU DIG

PRIVATE ENGINEERING NOTE

CONSTRUCTION CONTRACTOR AGREES THAT IN ACCORDANCE WITH GENERALLY ACCEPTED CONSTRUCTION PRACTICES, CONSTRUCTION CONTRACTOR WILL BE REQUIRED TO ASSUME SOLE AND COMPLETE RESPONSIBILITY FOR JOB SITE CONDITIONS DURING THE COURSE OF CONSTRUCTION OF THE PROJECT, INCLUDING SAFETY OF ALL PERSONS AND PROPERTY, THAT THIS REQUIREMENT SHALL BE MADE TO APPLY CONTINUOUSLY AND NOT BE LIMITED TO NORMAL WORKING HOURS, AND CONSTRUCTION CONTRACTOR FURTHER AGREES TO DEFEND, INDEMNIFY AND HOLD DESIGN PROFESSIONAL HARMLESS FROM ANY AND ALL LIABILITY, REAL OR ALLEGED, IN CONNECTION WITH THE PERFORMANCE OF WORK ON THIS PROJECT, EXCEPTING LIABILITY ARISING FROM THE SOLE NEGLIGENCE OF DESIGN PROFESSIONAL.

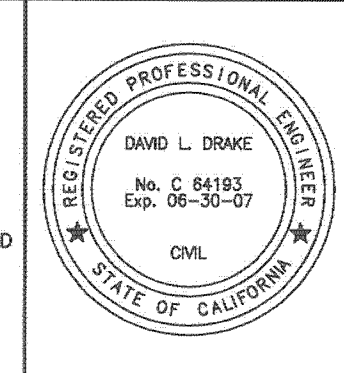

PREPARED UNDER THE DIRECTION OF:

*[Signature]*

REGISTERED CIVIL ENGINEER No. C 64193  
EXPIRATION DATE: 06-30-07 DATE: 11/26/06

PLANS PREPARED BY:

**PSOMAS**

2010 Iowa Avenue Suite 101 Riverside, CA 92507  
(951) 787-8421 Fax (951) 682-3379  
CITY OF RIVERSIDE TAX CERT NO: 69372 EXP: 4-07-07

SCALE: AS SHOWN BENCH MARK: F2-P2 CHISELED SQUARE ON THE TOP OF CURB AT THE WESTERLY END OF A CATCH BASIN FRONTING THE SOUTHERLY CURB OF INDIANA AVE. AT THE SOUTHEAST CORNER OF INDIANA AVENUE AND FILLMORE STREET. ELEV=738.410

MARK	REVISIONS	APPR.	DATE

DESIGNED BY: DD DRAWN BY: CA CHECKED BY: \_\_\_\_\_

CITY OF RIVERSIDE, CALIFORNIA  
DEPARTMENT OF PUBLIC WORKS

APPROVED BY: *[Signature]* DATE: 12/18/06  
PRINCIPAL ENGR. CITY ENGINEER

IN THE CITY OF RIVERSIDE, CALIFORNIA  
TRACT 32772-1  
SEWER IMPROVEMENT PLAN

LINE "B3" STA 11+50.00 TO STA 14+42.82  
LINE "B4" STA 00+00.00 TO STA 7+86.66

FOR: GRIFFIN INDUSTRIES

PW06-0329  
S-2002  
SHEET 6 OF 10  
FILE NO.: 1104-007

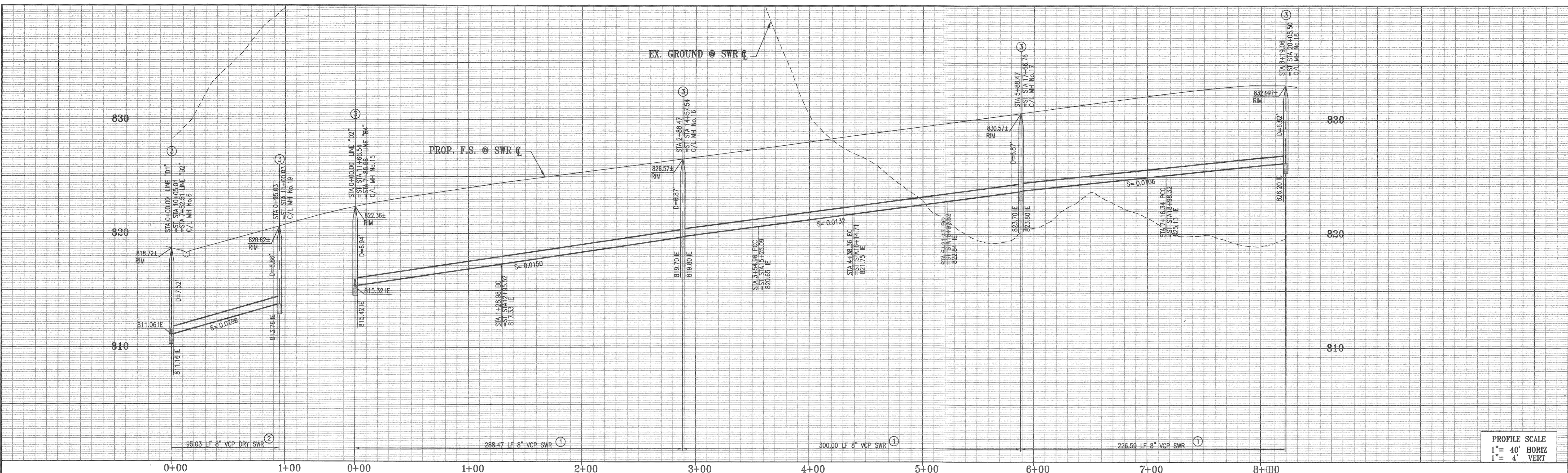

PROFILE SCALE  
1" = 40' HORIZ  
1" = 4' VERT

LINE "D1"

LINE "D2"

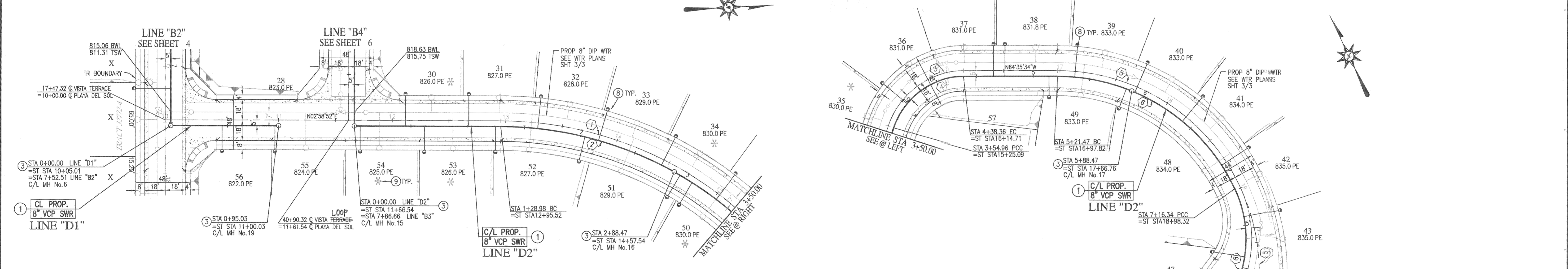

CURVE DATA

No.	DELTA	RADIUS	LENGTH	TANGENT
①	41°06'11"	320.00'	229.56'	119.97'
②	41°06'16"	315.00'	225.98'	118.10'
③	71°19'23"	72.00'	89.63'	51.66'
④	71°19'34"	66.99'	83.40'	48.07'
⑤	97°16'12"	178.00'	302.19'	202.15'
⑥	64°32'16"	173.00'	194.87'	109.23'
⑦	53°17'19"	107.92'	100.37'	54.15'
⑧	57°11'05"	102.92'	102.72'	56.10'

PLAYA DEL SOL

CONSTRUCTION NOTES

- ① CONSTRUCT 8" VCP SEWER MAIN W/ PIPE bedding CASE 1 PER OR. STD. DWG. NO. 452
- ② CONSTRUCT 48" SEWER MANHOLE PER CITY OF RIV. STD. DWG. NO. 500.
- ③ CONSTRUCT 4" SEWER LATERAL W/CLEANOUT PER CITY RIV. STD. DWG. NO. 562A
- ④ INSTALL 4" BACKWATER VALVE

PUBLIC UTILITIES DEPARTMENT  
WATER DIVISION

APPROVED BY: *MW M. Del* DATE: 11/30/06

Underground Service Alert  
Call: TOLL FREE  
1 - 800  
227-2600

TWO WORKING DAYS BEFORE YOU DIG

PRIVATE ENGINEERING NOTE

CONSTRUCTION CONTRACTOR AGREES THAT IN ACCORDANCE WITH GENERALLY ACCEPTED CONSTRUCTION PRACTICES, CONSTRUCTION CONTRACTOR WILL BE REQUIRED TO ASSUME SOLE AND COMPLETE RESPONSIBILITY FOR JOB SITE CONDITIONS DURING THE COURSE OF CONSTRUCTION OF THE PROJECT, INCLUDING SAFETY OF ALL PERSONS AND PROPERTY; THAT THIS REQUIREMENT SHALL BE MADE TO APPLY CONTINUOUSLY AND NOT BE LIMITED TO NORMAL WORKING HOURS; AND CONSTRUCTION CONTRACTOR FURTHER AGREES TO DEFEND, INDEMNIFY AND HOLD DESIGN PROFESSIONAL HARMLESS FROM ANY AND ALL LIABILITY, REAL OR ALLEGED, IN CONNECTION WITH THE PERFORMANCE OF WORK ON THIS PROJECT, EXCEPTING LIABILITY ARISING FROM THE SOLE NEGLIGENCE OF DESIGN PROFESSIONAL.

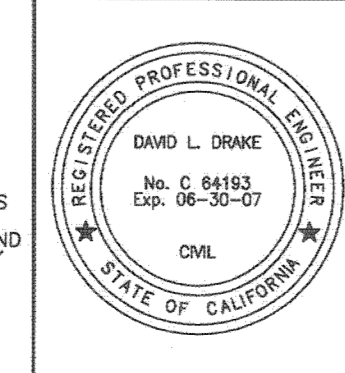

PREPARED UNDER THE DIRECTION OF:

PLANS PREPARED BY:

**PSOMAS**

2010 Iowa Avenue Suite 101 Riverside, CA 92507  
(951) 787-8421 Fax (951) 682-3379  
CITY OF RIVERSIDE TAX CERT NO: 69372 EXP: 4-07-07

SCALE: AS SHOWN

REGISTERED CIVIL ENGINEER NO. C 64193 DATE: 11/20/06

EXPIRATION DATE: 06-30-07

DESIGNED BY: DD DRAWN BY: CA CHECKED BY: \_\_\_\_\_

MARK: \_\_\_\_\_ REVISIONS: \_\_\_\_\_ APPR. DATE: \_\_\_\_\_

CITY OF RIVERSIDE, CALIFORNIA  
DEPARTMENT OF PUBLIC WORKS

APPROVED BY: \_\_\_\_\_ BY: \_\_\_\_\_ DATE: \_\_\_\_\_

PRINCIPAL ENGR. \_\_\_\_\_ CITY ENGINEER: *[Signature]* DATE: 11/30/06

IN THE CITY OF RIVERSIDE, CALIFORNIA  
TRACT 32772-1  
SEWER IMPROVEMENT PLAN

PW06-0329  
S-2002

LINE "D1" STA 00+00.00 TO STA 0+95.03  
LINE "D2" STA 00+00.00 TO STA 8+19.06

FOR: GRIFFIN INDUSTRIES

SHEET 7 OF 10  
FILE NO.: 1104-007

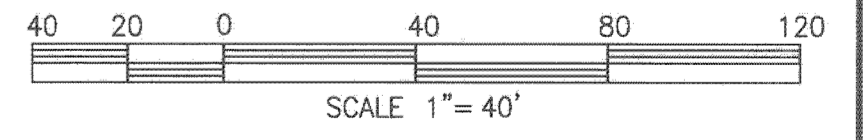

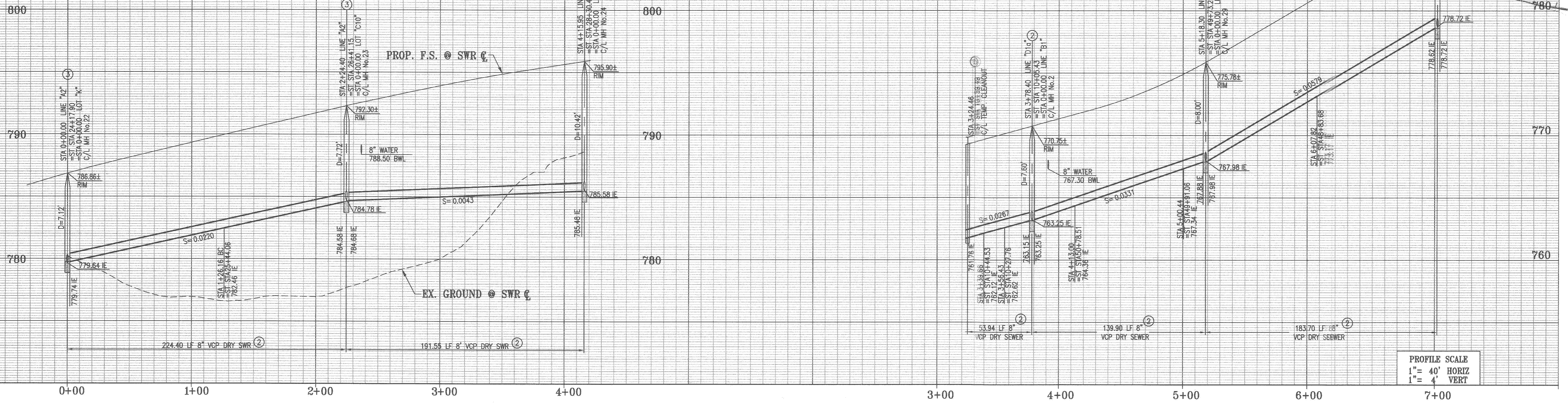

PROFILE SCALE  
1" = 40' HORIZ  
1" = 4' VERT

LINE "A2"

LINE "D1a"

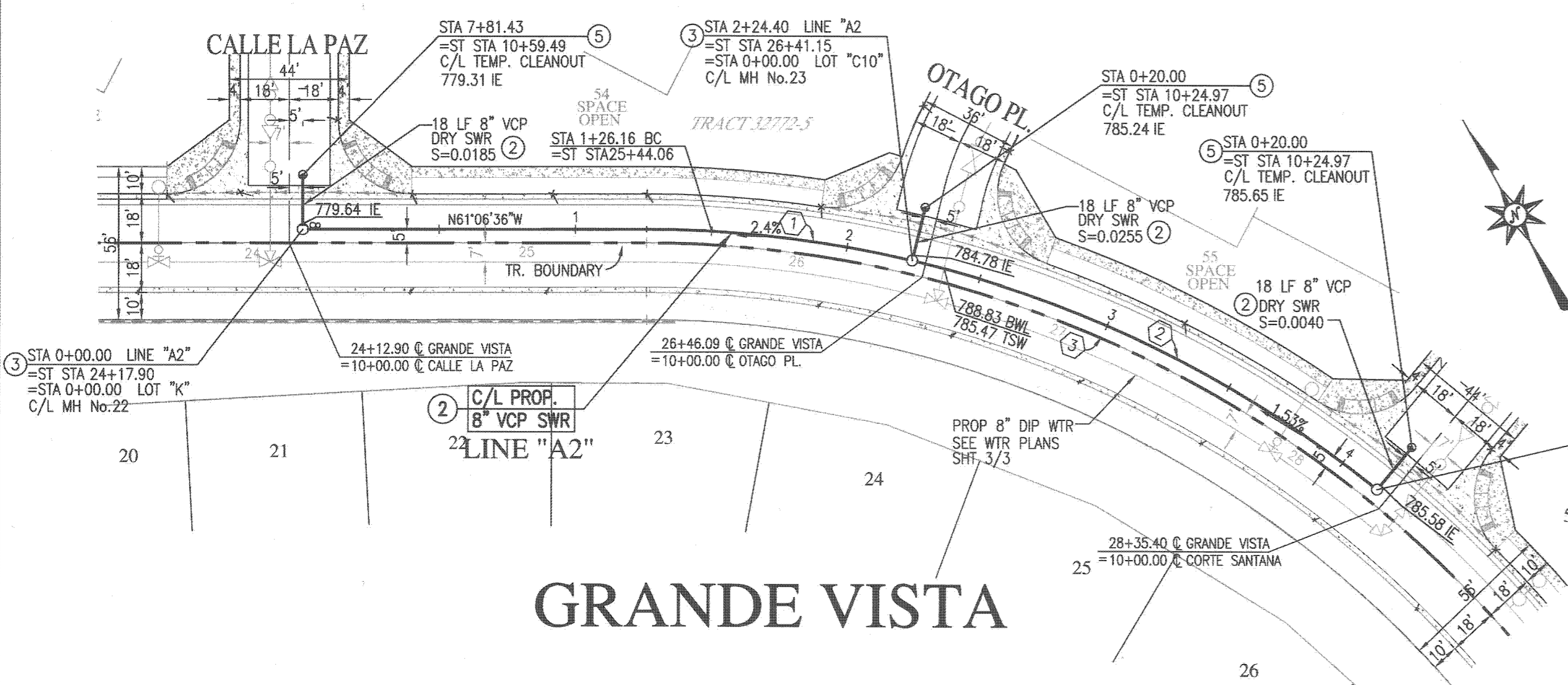

**CURVE DATA**

No.	DELTA	RADIUS	LENGTH	TANGENT
1	12°54'48"	427.00'	96.24'	48.32'
2	25°09'59"	427.00'	187.55'	95.31'
3	55°05'36"	422.00'	405.78'	220.12'
4	02°51'23"	305.00'	15.21'	7.60'
5	03°08'19"	300.00'	16.43'	8.22'
6	05°18'08"	300.00'	27.76'	13.89'
7	03°52'39"	295.00'	19.96'	9.99'
8	05°55'03"	300.00'	32.58'	16.30'
9	02°06'07"	295.00'	17.87'	8.93'
10	10°31'56"	487.00'	89.52'	44.89'

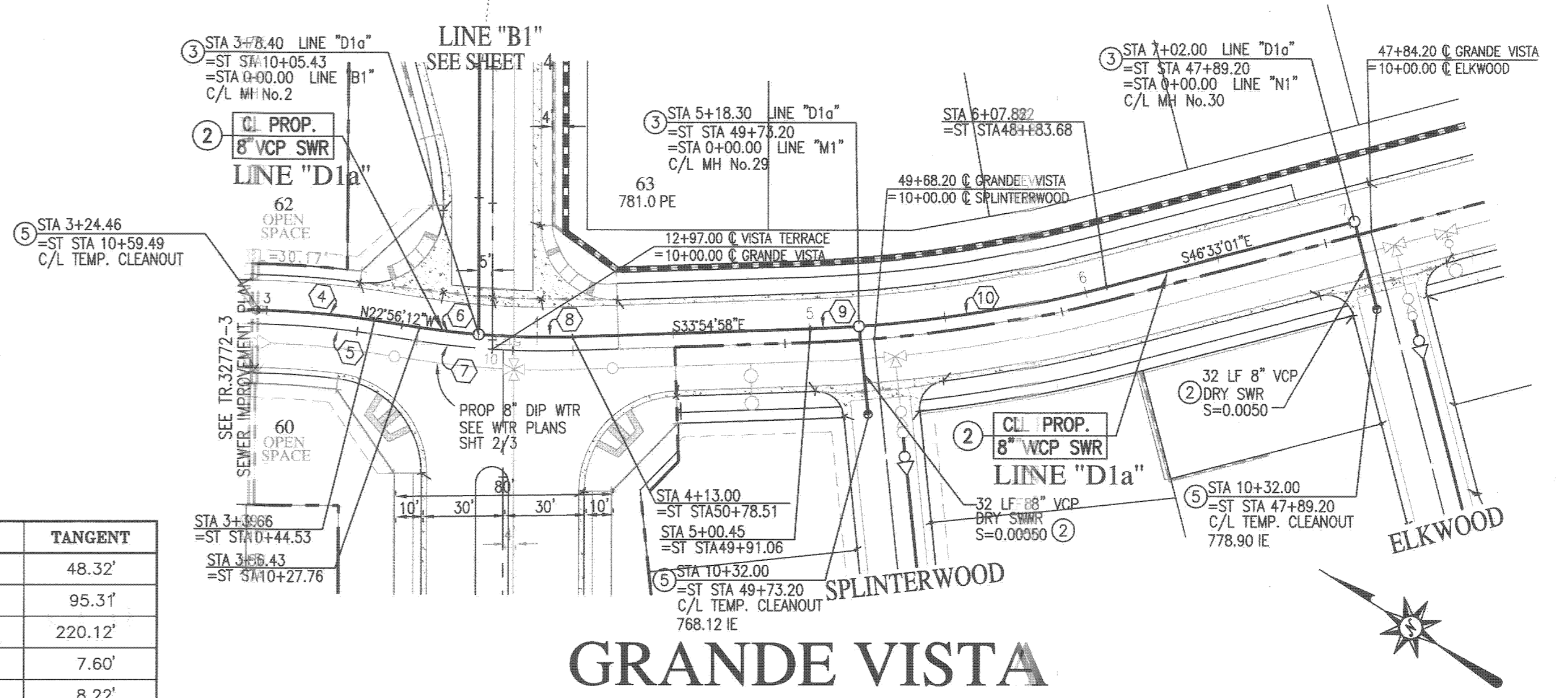

- CONSTRUCTION NOTES**
- 2) CONSTRUCT 8" DRY VCP SEWER MAIN W/ PIPE BEDDING CASE 5 (PPR) COR. SHT. 2/3
  - 3) CONSTRUCT 48" SEWER MANHOLE PER CITY OF RIV. STD. DWG. NO. 500.
  - 5) INSTALL TEMP. SEWER CLEAN-OUT PER CITY OF RIV. STD. DWG. NO. 560

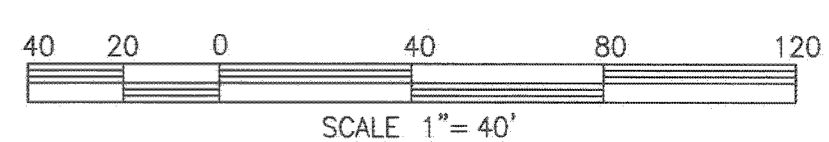

WDID: 8 33C334294

PUBLIC UTILITIES DEPARTMENT  
WATER DIVISION

APPROVED BY: *MW M...* DATE: 11/30/06

**PRIVATE ENGINEERING NOTE**

CONTRACTOR AGREES THAT IN ACCORDANCE WITH GENERALLY ACCEPTED CONSTRUCTION PRACTICES, CONSTRUCTION CONTRACTOR WILL BE REQUIRED TO ASSUME SOLE AND COMPLETE RESPONSIBILITY FOR JOB SITE CONDITIONS DURING THE COURSE OF CONSTRUCTION OF THE PROJECT, INCLUDING SAFETY OF ALL PERSONS AND PROPERTY, THAT THIS REQUIREMENT SHALL BE MADE TO APPLY CONTINUOUSLY AND NOT BE LIMITED TO NORMAL WORKING HOURS, AND CONSTRUCTION CONTRACTOR FURTHER AGREES TO DEFEND, INDEMNIFY AND HOLD DESIGN PROFESSIONAL HARMLESS FROM ANY AND ALL LIABILITY, REAL OR ALLEGED, IN CONNECTION WITH THE PERFORMANCE OF WORK ON THIS PROJECT, EXCEPTING LIABILITY ARISING FROM THE SOLE NEGLIGENCE OF DESIGN PROFESSIONAL.



PREPARED UNDER THE DIRECTION OF:  
*[Signature]*

REGISTERED CIVIL ENGINEER NO. C 64183  
EXPIRATION DATE: 06-30-07 DATE: 11/28/06

PLANS PREPARED BY:  
**PSOMAS**

2010 Iowa Avenue Suite 101 Riverside, CA 92507  
(951) 787-8421 Fax (951) 682-3379  
CITY OF RIVERSIDE TAX CERT NO: 69372 EXP: 4-07-07

SCALE: AS SHOWN  
BENCH MARK: E2-P2 CHISELED SQUARE ON THE TOP OF CURB AT THE WESTERLY END OF A CATCH BASIN FRONTING THE SOUTHERLY CURB OF INDIANA AVE. AT THE SOUTHEAST CORNER OF INDIANA AVENUE AND FILLMORE STREET. ELEV=738.410

MARK	REVISIONS	APPR. DATE

DESIGNED BY: DD DRAWN BY: CA CHECKED BY: [Signature]

CITY OF RIVERSIDE, CALIFORNIA  
DEPARTMENT OF PUBLIC WORKS

APPROVED BY: [Signature] DATE: 11/28/06  
PRINCIPAL ENGR.

IN THE CITY OF RIVERSIDE, CALIFORNIA  
TRACT 32772-1  
SEWER IMPROVEMENT PLAN

LINE "A2" STA 00+00.00 TO STA 44+15.95  
LINE "D1a" STA 3+24.46 TO STA 3+78.40

FOR: GRIFFIN INDUSTRIES

PW06-0329  
S-2002  
SHEET 8 OF 10  
FILE NO.: 1104-007

INDEXED 2-9-07 LFL



NOT A PART; FOR DESIGN REFERENCE ONLY

NOT A PART; FOR DESIGN REFERENCE ONLY

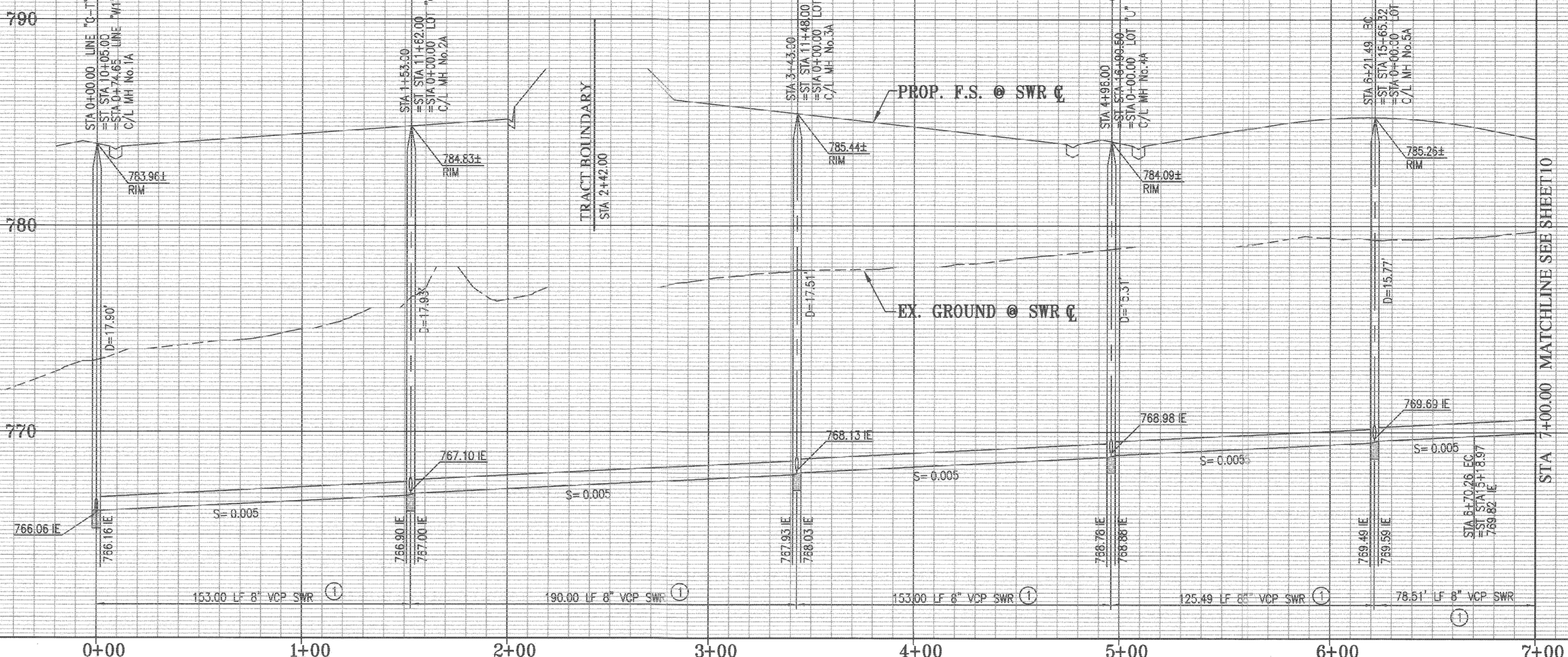
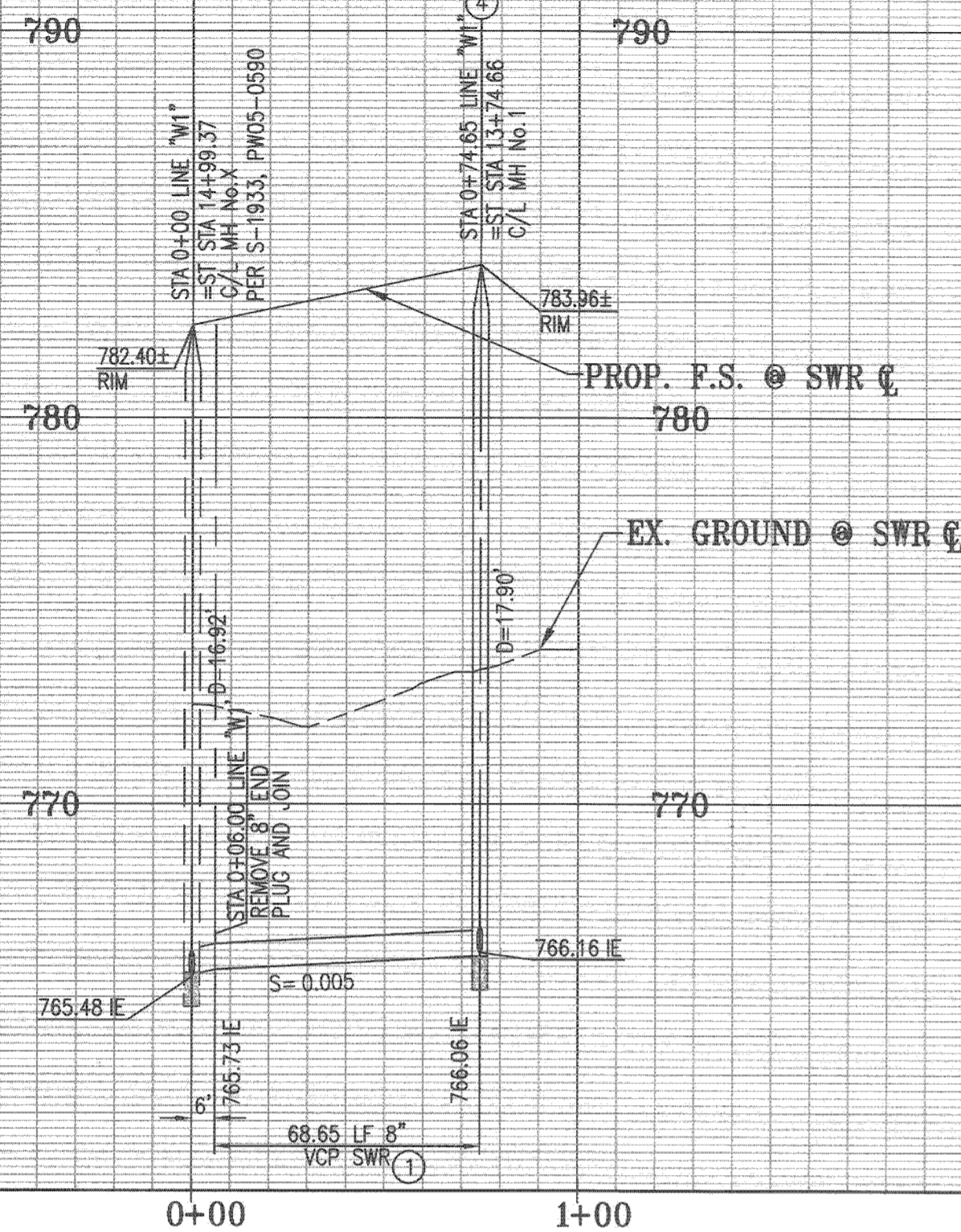

PROFILE SCALE  
1" = 40' HORIZ  
1" = 4' VERT

LINE "W1"

LINE "C-T"

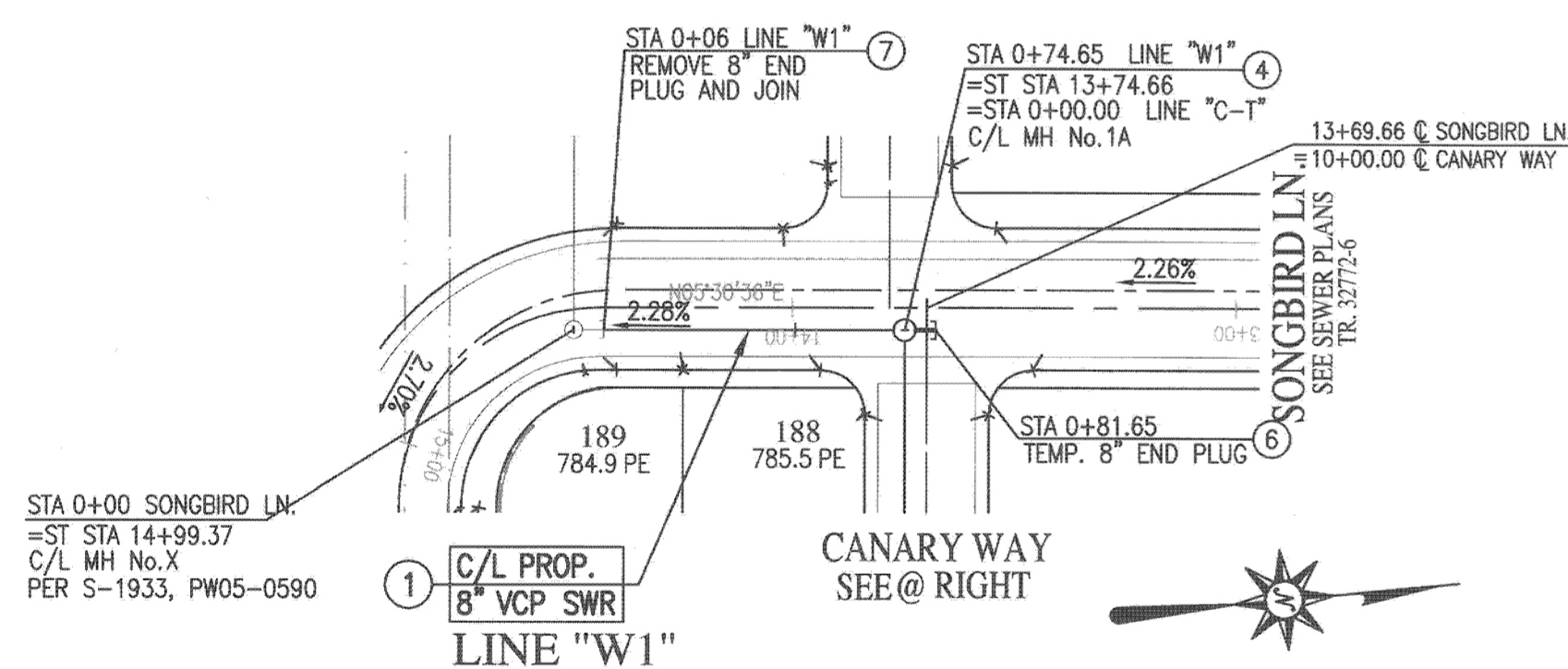

SONGBIRD LN.  
TR 32772-6

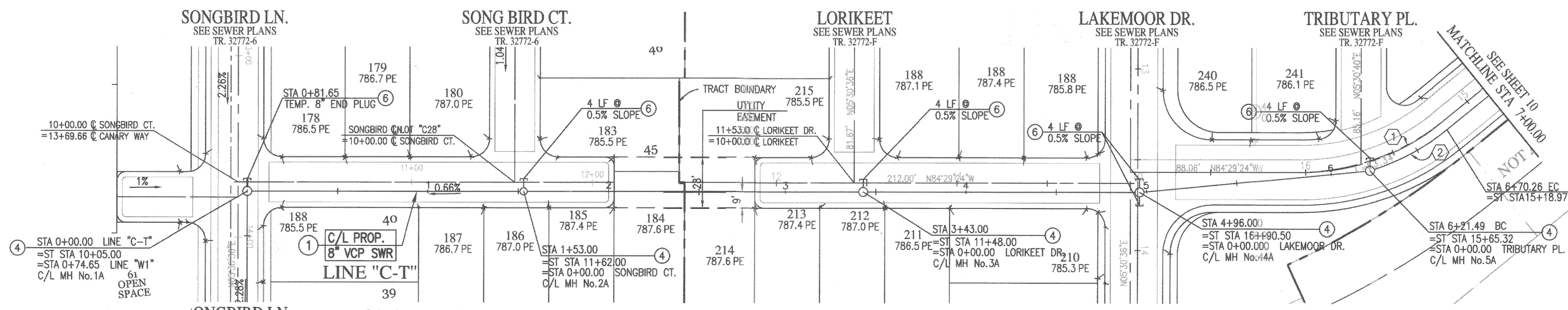

CANARY WAY  
TR 32772-6

LORIKEET DR.  
TR 32772-F

LIGHTHOUSE LN.

**CURVE DATA**

No.	DELTA	RADIUS	LENGTH	TANGENT
①	39°08'28"	122.00"	83.34"	43.37"
②	21°05'48"	127.00"	46.76"	23.65"

- CONSTRUCTION NOTES**
- ① CONSTRUCT 8" VCP SEWER MAIN. W/ PIPE BEARING CASE 1 PER COR STD. DWG. No. 452
  - ② CONSTRUCT 60" SEWER MANHOLE PER CITY OF RIV. STD. DWG. No. 500.
  - ③ INSTALL TEMP. 8" END PLUG
  - ④ REMOVE 8" END PLUG AND JOIN

NOT A PART  
FOR DESIGN REFERENCE ONLY

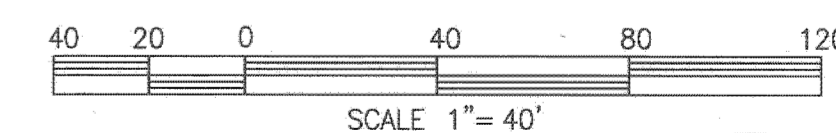

PUBLIC UTILITIES DEPARTMENT  
WATER DIVISION

APPROVED BY: *MW MEd* DATE: 11/30/06

PRIVATE ENGINEERING NOTE

CONSTRUCTION CONTRACTOR AGREES THAT IN ACCORDANCE WITH GENERALLY ACCEPTED CONSTRUCTION PRACTICES, CONSTRUCTION CONTRACTOR WILL BE REQUIRED TO ASSUME SOLE AND COMPLETE RESPONSIBILITY FOR JOB SITE CONDITIONS DURING THE COURSE OF CONSTRUCTION OF THE PROJECT, INCLUDING SAFETY OF ALL PERSONS AND PROPERTY; THAT THIS REQUIREMENT SHALL BE MADE TO APPLY CONTINUOUSLY AND NOT BE LIMITED TO NORMAL WORKING HOURS; AND CONSTRUCTION CONTRACTOR FURTHER AGREES TO DEFEND, INDEMNIFY AND HOLD DESIGN PROFESSIONAL HARMLESS FROM ANY AND ALL LIABILITY, REAL OR ALLEGED, IN CONNECTION WITH THE PERFORMANCE OF WORK ON THIS PROJECT, EXCEPTING LIABILITY ARISING FROM THE SOLE NEGLIGENCE OF DESIGN PROFESSIONAL.



PREPARED UNDER THE DIRECTION OF:  
*[Signature]*  
REGISTERED CIVIL ENGINEER NO. C 64193  
EXPIRATION DATE: 06-30-07 DATE: 11/23/06

PLANS PREPARED BY:  
**PSOMAS**  
2010 Iowa Avenue Suite 101 Riverside, CA 92507  
(951) 787-8421 Fax (951) 682-3379  
CITY OF RIVERSIDE TAX CERT NO: 69372 EXP: 4-07-07  
SCALE: AS SHOWN  
BENCH MARK: E2-P2 CHISELED SQUARE ON THE TOP OF CURB AT THE WESTERLY END OF A CATCH BASIN FRONTING THE SOUTHERLY CURB OF INDIANA AVE. AT THE SOUTHEAST CORNER OF INDIANA AVENUE AND FILLMORE STREET. ELEV=738.410  
DATE: FEBRUARY 2006

CITY OF RIVERSIDE, CALIFORNIA  
DEPARTMENT OF PUBLIC WORKS

APPROVED BY: *[Signature]* DATE: 11/23/06  
PRINCIPAL ENGR. CITY ENGINEER

IN THE CITY OF RIVERSIDE, CALIFORNIA  
TRACT 32772-1  
SEWER IMPROVEMENT PLAN

LINE "W1" STA 00+06.00 TO STA 0+81.65  
LINE "C-T" STA 00+00.00 TO STA 7+00.00

FOR: GRIFFIN INDUSTRIES

WDID: 8 33C334294

PW06-0329

S-2002

SHEET 9 OF 10

FILE NO.: 1104-007

INDEXED 2-5-07 Lft

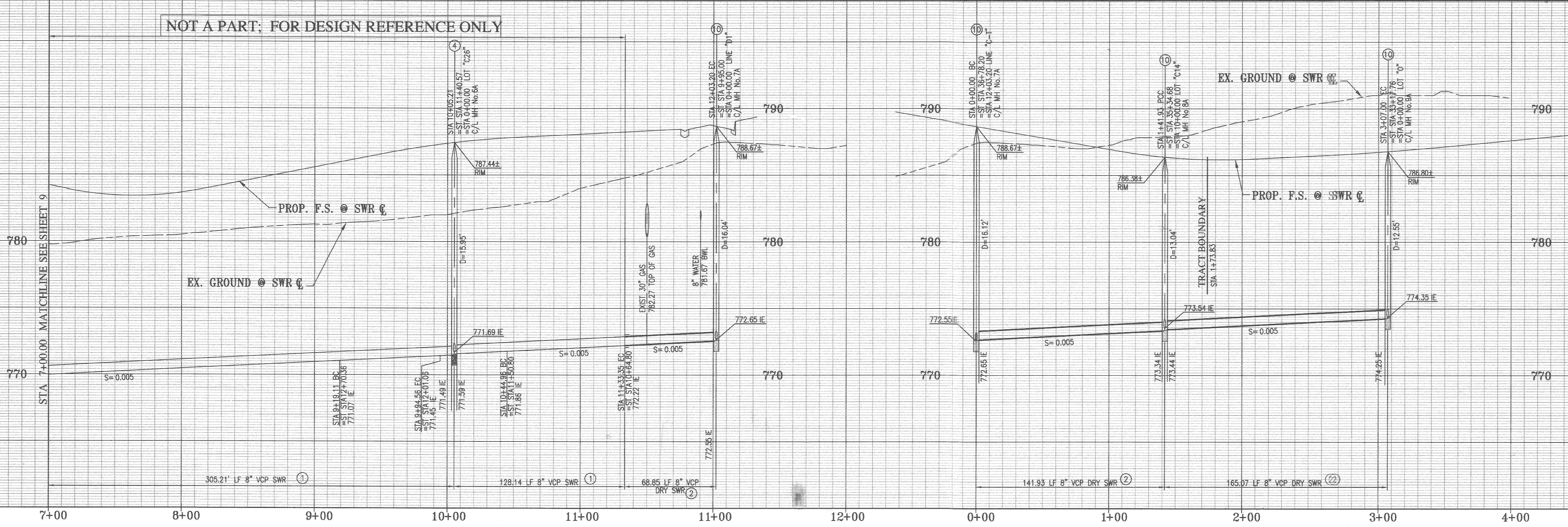

PROFILE SCALE  
1" = 40' HORIZ  
1" = 4' VERT

LINE "C-T"

LINE "D1"

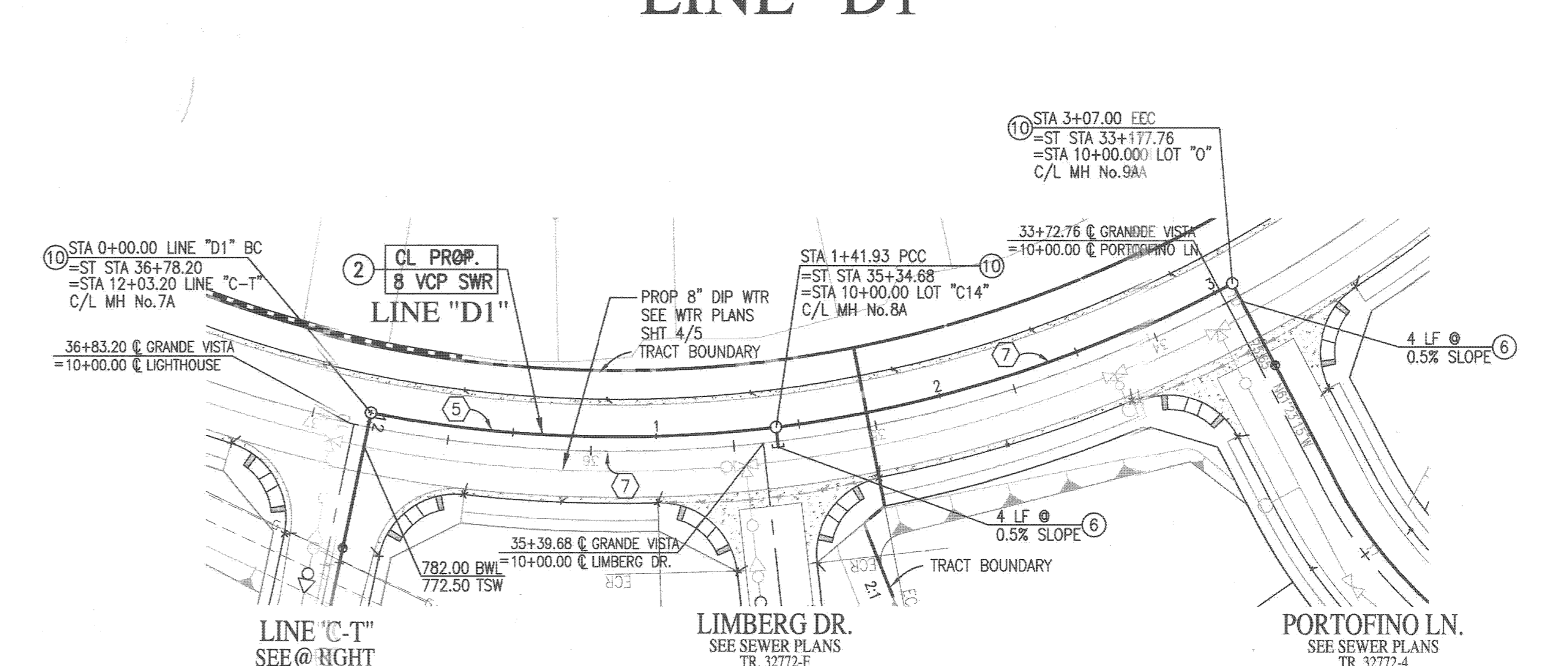
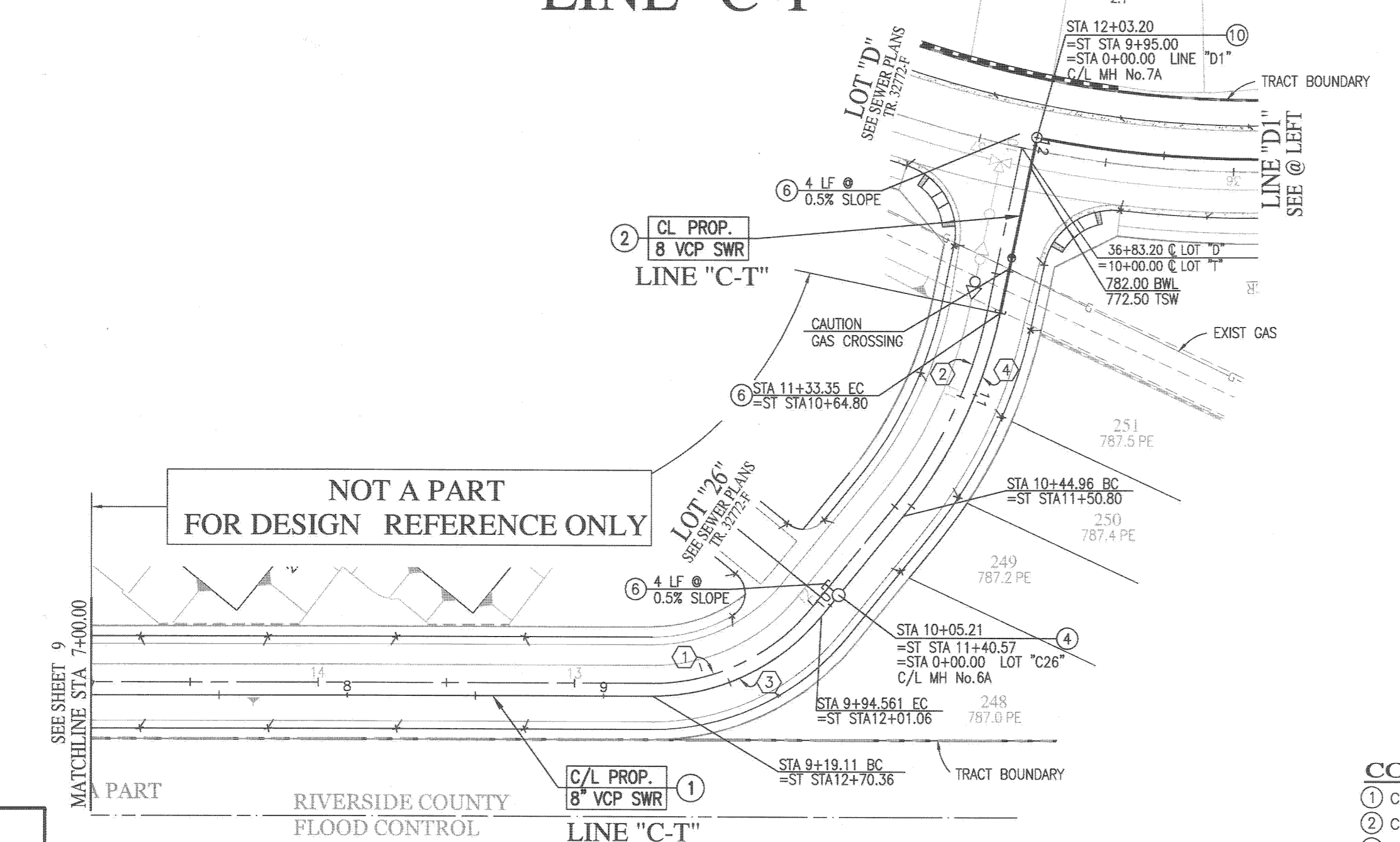

GRANDE VISTA

CURVE DATA

No.	DELTA	RADIUS	LENGTH	TANGENT
①	50°51'32"	80.00'	71.01'	38.04'
②	27°37'02"	180.00'	86.76'	44.24'
③	50°51'32"	85.00'	75.45'	40.41'
④	27°22'14"	185.00'	88.38'	45.05'
⑤	17°45'32"	445.00'	137.93'	69.52'
⑥	20°44'17"	445.00'	161.07'	81.42'
⑦	74°14'42"	450.00'	583.12'	3340.61'

CONSTRUCTION NOTES

- ① CONSTRUCT 8" VCP SEWER MAIN. W/Pipe bedding case 3 per spec and per city DWG No. 452.
- ② CONSTRUCT 8" DRY VCP SEWER MAIN.
- ③ CONSTRUCT 60" SEWER MANHOLE PER CITY OF RIV. STD. DWG No. 500.
- ④ INSTALL TEMP. 8" END PLUG
- ⑤ INSTALL 48" DRY SEWER MANHOLE PER CITY OF RIV. STD. DWG No. 500.
- ⑥ ALL RIMS TO BE PAVED OVER TO RESTRICT ACCESS.

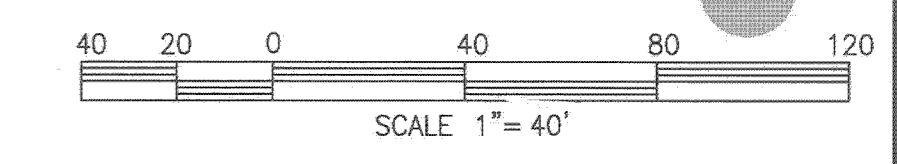

PUBLIC UTILITIES DEPARTMENT  
WATER DIVISION

APPROVED BY: *MW McLeod* 11/30/06  
DATE

LIGHTHOUSE LN.  
TR 32772-F

PRIVATE ENGINEERING NOTE

CONSTRUCTION CONTRACTOR AGREES THAT IN ACCORDANCE WITH GENERALLY ACCEPTED CONSTRUCTION PRACTICES, CONSTRUCTION CONTRACTOR WILL BE REQUIRED TO ASSUME SOLE AND COMPLETE RESPONSIBILITY FOR JOB SITE CONDITIONS DURING THE COURSE OF CONSTRUCTION OF THE PROJECT, INCLUDING SAFETY OF ALL PERSONS AND PROPERTY, THAT THIS REQUIREMENT SHALL BE MADE TO APPLY CONTINUOUSLY AND NOT BE LIMITED TO NORMAL WORKING HOURS, AND CONSTRUCTION CONTRACTOR FURTHER AGREES TO DEFEND, INDEMNIFY AND HOLD DESIGN PROFESSIONAL HARMLESS FROM ANY AND ALL LIABILITY, REAL OR ALLEGED, IN CONNECTION WITH THE PERFORMANCE OF WORK ON THIS PROJECT, EXCEPTING LIABILITY ARISING FROM THE SOLE NEGLIGENCE OF DESIGN PROFESSIONAL.

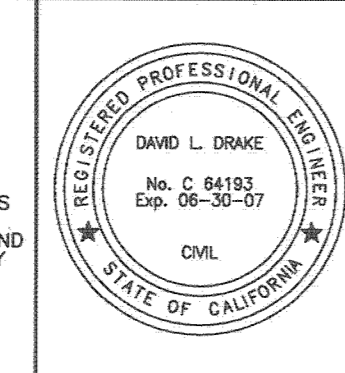

PREPARED UNDER THE DIRECTION OF:

PLANS PREPARED BY:

**PSOMAS**

2010 Iowa Avenue Suite 101 Riverside, CA 92507  
(951) 787-8421 Fax (951) 682-3379  
CITY OF RIVERSIDE TAX CERT NO: 69372 EXP: 4-07-07

SCALE: AS SHOWN BENCH MARK: E2-P2 CHESELED SQUARE ON THE TOP OF CURB AT THE WESTERLY END OF A CATCH BASIN FRONTING THE SOUTHERLY CURB OF INDIANA AVE. AT THE SOUTHEAST CORNER OF INDIANA AVENUE AND FILLMORE STREET. ELEV=738.410

REGISTERED CIVIL ENGINEER NO. C 64193  
EXPIRATION DATE: 06-30-07 DATE: *11/30/06*

CITY OF RIVERSIDE, CALIFORNIA  
DEPARTMENT OF PUBLIC WORKS

APPROVED BY: *[Signature]*  
PRINCIPAL ENGR. DATE: *11/30/06*

APPROVED BY: *[Signature]*  
CITY ENGINEER DATE: *11/30/06*

MARK REVISIONS APPR. DATE  
DESIGNED BY: DD DRAWN BY: CA CHECKED BY: *[Signature]*

IN THE CITY OF RIVERSIDE, CALIFORNIA  
TRACT 32772-1  
SEWER IMPROVEMENT PLAN  
PW06-0329  
S-2002  
LINE "C-T" STA 7+00.00 TO STA 12+03.20  
LINE "D1" STA 00+00.00 TO STA 3+07.00  
SHEET 10 OF 10  
FOR: GRIFFIN INDUSTRIES  
FILE NO: 1104-007