

IN THE CITY OF RIVERSIDE, CALIFORNIA

SEWER IMPROVEMENT PLANS

TRACT 32772-3

GENERAL NOTES

1. THE PRIVATE ENGINEER SIGNING THESE PLANS IS RESPONSIBLE FOR ASSURING THE ACCURACY AND ACCEPTABILITY OF THE WORK HEREON. IN THE EVENT OF DISCREPANCIES ARISING DURING CONSTRUCTION, THE PRIVATE ENGINEER SHALL BE RESPONSIBLE FOR DETERMINING AN ACCEPTABLE SOLUTION AND REVISING THE PLANS FOR APPROVAL BY THE CITY.
2. IT SHALL BE THE RESPONSIBILITY OF THE CONTRACTOR TO CLEAR THE RIGHT OF WAY IN ACCORDANCE WITH THE PROVISIONS OF LAW AS IT AFFECTS EACH UTILITY INCLUDING IRRIGATION LINES AND APPURTENANCES AND AT NO COST TO THE CITY.
3. CONSTRUCTION SHALL BE IN ACCORDANCE WITH THE CITY OF RIVERSIDE DEPT. OF PUBLIC WORKS, STANDARD DRAWINGS, ITS SUPPLEMENTAL NOTES AND THE STANDARD SPECIFICATIONS FOR PUBLIC WORKS CONSTRUCTION, CURRENT EDITION.
4. CONTRACTOR IS TO VERIFY EXISTING SEWER ELEVATION PRIOR TO CONSTRUCTION.
5. THE SEWER CONTRACTOR SHALL ADJUST MANHOLES TO FINAL GRADE AFTER PAVING IS COMPLETED.
6. A PLUG SHALL BE INSTALLED AND WILL REMAIN IN PLACE WHERE THE NEW SEWER CONNECTS WITH THE EXISTING SEWER UNTIL THE NEW SEWER IS ACCEPTED BY THE CITY OF RIVERSIDE.
7. ANY TRAFFIC CONTROL STRIPING OBLITERATED AND/OR BADLY WORN DURING CONSTRUCTION SHALL BE RESTORED BY THE CONTRACTOR WITHIN FIVE DAYS AFTER NOTIFICATION FROM THE CITY INSPECTORS.
8. ALL FLAGGED ELEVATIONS SHALL BE STAKED IN THE FIELD BY THE PRIVATE ENGINEER.
9. THE CONTRACTOR SHALL CALL IN A LOCATIONS REQUEST TO UNDERGROUND SERVICE ALERT (USA), PHONE NO. 1-800-227-2600, TWO WORKING DAYS BEFORE DIGGING NO CONSTRUCTION PERMIT WILL BE ISSUED BY THE PUBLIC WORKS DEPARTMENT INVOLVING EXCAVATION FOR UNDERGROUND FACILITIES UNLESS THE APPLICANT HAS BEEN PROVIDED AN INQUIRY IDENTIFICATION NUMBER BY U.S.A.
10. THE DEVELOPER SHALL BE RESPONSIBLE FOR PRESERVING OR RE-ESTABLISHING AND REFERENCING SURVEY MONUMENTS DESTROYED, DISTURBED OR BURIED AS A RESULT OF CONSTRUCTION SHOWN HEREON.
11. NOTICE TO CONTRACTOR. THE EXISTENCE AND LOCATION OF ANY UNDERGROUND UTILITY PIPES OR STRUCTURES SHOWN ON THESE PLANS WERE OBTAINED BY A SEARCH OF AVAILABLE RECORDS. TO THE BEST OF OUR KNOWLEDGE THERE ARE NO EXISTING UTILITIES EXCEPT AS SHOWN ON THESE PLANS. THE CONTRACTOR IS REQUIRED TO TAKE PRECAUTIONARY MEASURES TO PROTECT THE UTILITY LINES SHOWN ON ANY OTHER LINES NOT OF RECORD OR NOT SHOWN ON THESE PLANS.
15. PRIOR TO CONSTRUCTION THE CONTRACTOR SHALL POTHOLE ALL UTILITY CROSSING AND CONNECTIONS AND VERIFY THE LOCATION AND ELEVATION OF ALL UTILITIES AFFECTED. THE ENGINEER SHALL BE NOTIFIED OF ANY DISCREPANCIES BEFORE CONSTRUCTION BEGINS.
16. NO PERSON SHALL PERFORM ANY CONSTRUCTION ACTIVITY OR INSTALL ANY OBJECTS WITHIN THE PUBLIC RIGHTS-OF-WAY OR EASEMENTS OF THE CITY OF RIVERSIDE WITHOUT A VALID CONSTRUCTION PERMIT OR, A STREET OPENING PERMIT OR AN ENCROACHMENT PERMIT ISSUED BY THE CITY'S PUBLIC WORKS DEPARTMENT.
17. ON ALL AREAS WITHIN PUBLIC RIGHT-OF-WAY WHERE THE FILL IS ONE (1) FOOT OR GREATER, A LETTER WILL BE REQUIRED FROM THE SOILS ENGINEER, CERTIFYING THE COMPACTION OF THE FILL BELOW SUBGRADE, PRIOR TO ISSUANCE OF THE CONSTRUCTION PERMIT/CUT SHEETS.

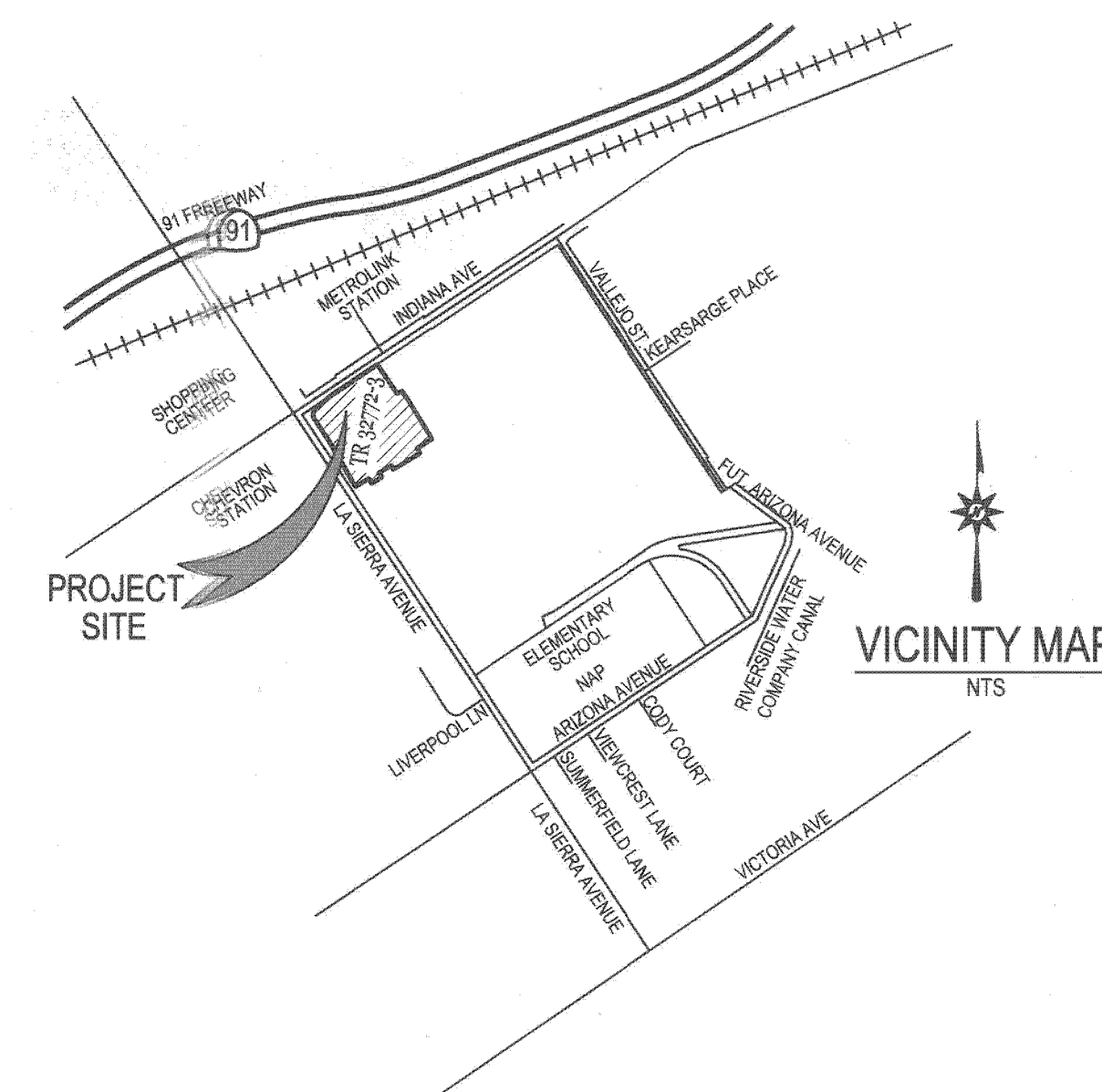

LEGEND

- PROPOSED 8" VCP SEWER MAIN
- PROPOSED SEWER MANHOLE
- PROPOSED SEWER CLEAN-OUT
- - - EXISTING SEWER LINE
- ⊙ EXISTING SEWER MANHOLE
- * 4" BACKWATER VALVE
- ← 1 → SEWER LATERAL
- ← 1 → SHEET NUMBER
- - - TRACT BOUNDARY

CONSTRUCTION NOTES

	QNTY	UNITS
① CONSTRUCT 8" VCP SEWER MAIN W/PIPE BEDDING CASE 1 PER C.O.R. STD. DWG. 452	2,332	LF
② CONSTRUCT 48" SEWER MANHOLE PER CITY OF RIV. STD. DWG No. 500	23	EA
③ REMOVE 8" END PLUG AND JOIN	1	EA
④ CONSTRUCT 4" SEWER LATERAL WITH CLEANOUT PER CITY RIV. STD. DWG. No. 562A	852	LF
⑤ INSTALL 4" BACKWATER VALVE	9	EA
⑥ REMOVE TEMP. SEWER CLEANOUT AND JOIN	1	EA

PUBLIC UTILITIES DEPARTMENT
WATER DIVISION

[Signature] 1/2/07
APPROVED BY DATE

Underground Service Alert
Call: TOLL FREE
1 - 800
227-2600
TWO WORKING DAYS BEFORE YOU DIG

PRIVATE ENGINEERING NOTE

CONSTRUCTION CONTRACTOR AGREES THAT IN ACCORDANCE WITH GENERALLY ACCEPTED CONSTRUCTION PRACTICES, CONSTRUCTION CONTRACTOR WILL BE REQUIRED TO ASSUME SOLE AND COMPLETE RESPONSIBILITY FOR JOB SITE CONDITIONS DURING THE COURSE OF CONSTRUCTION OF THE PROJECT INCLUDING SAFETY OF ALL PERSONS AND PROPERTY. THAT THIS REQUIREMENT SHALL BE MADE TO APPLY CONTINUOUSLY AND NOT BE LIMITED TO NORMAL WORKING HOURS; AND CONSTRUCTION CONTRACTOR FURTHER AGREES TO DEFEND, INDEMNIFY AND HOLD DESIGN PROFESSIONAL HARMLESS FROM ANY AND ALL LIABILITY, REAL OR ALLEGED, IN CONNECTION WITH THE PERFORMANCE OF WORK ON THIS PROJECT, EXCEPTING LIABILITY ARISING FROM THE SOLE NEGLIGENCE OF DESIGN PROFESSIONAL.

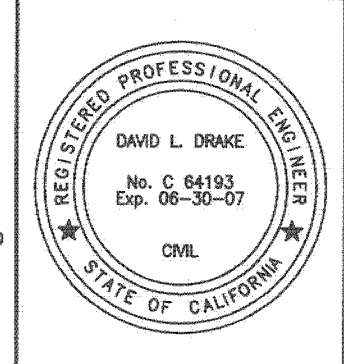

PREPARED UNDER THE DIRECTION OF:

[Signature]
REGISTERED CIVIL ENGINEER NO. C 64193
EXPIRATION DATE: 08-30-07 DATE: 1-2-07

PLANS PREPARED BY:

PSOMAS
2010 Iowa Avenue Suite 101 Riverside, CA 92507
(951) 787-8421 Fax (951) 682-3379
CITY OF RIVERSIDE TAX CERT NO: 69372 EXP: 4-07-07

SCALE: AS SHOWN
DATE: NOVEMBER 2006

BENCH MARK: E2-P2 CHISELED SQUARE ON THE TOP OF CURB AT THE WESTERLY END OF A CATCH BASIN FRONTING THE SOUTHERLY CURB OF INDIANA AVE. AT THE SOUTHEAST CORNER OF INDIANA AVENUE AND FILLMORE STREET. ELEV=738.410

MARK	REVISIONS	APPR.	DATE

DESIGNED BY DD DRAWN BY CA CHECKED BY

CITY OF RIVERSIDE, CALIFORNIA
DEPARTMENT OF PUBLIC WORKS

APPROVED BY: *[Signature]*
PRINCIPAL ENGR. DATE 1/5/07

IN THE CITY OF RIVERSIDE, CALIFORNIA
TRACT 32772-3
SEWER IMPROVEMENT PLAN
TITLE SHEET
FOR: GRIFFIN INDUSTRIES

PW06-0482
S-2004
SHEET 1 OF 5
FILE NO.: 1104-007

WDID: 8 33C334294

INDEXED 1-26-07 LfH

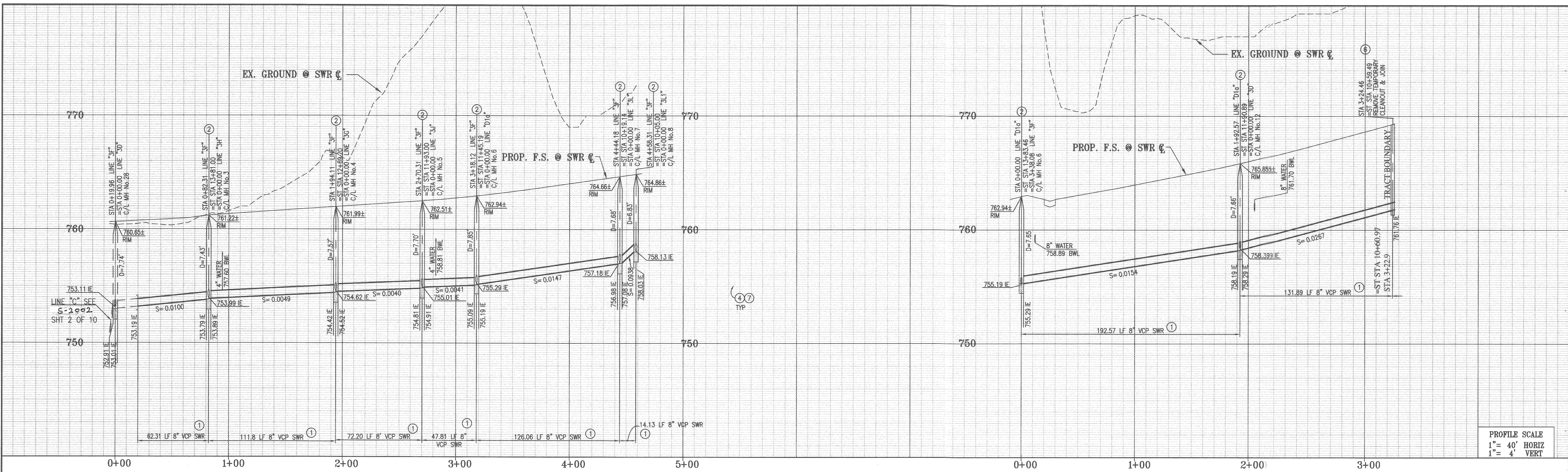

PROFILE SCALE
1" = 40' HORIZ
1" = 4' VERT

LINE "3F"

LINE "D1a"

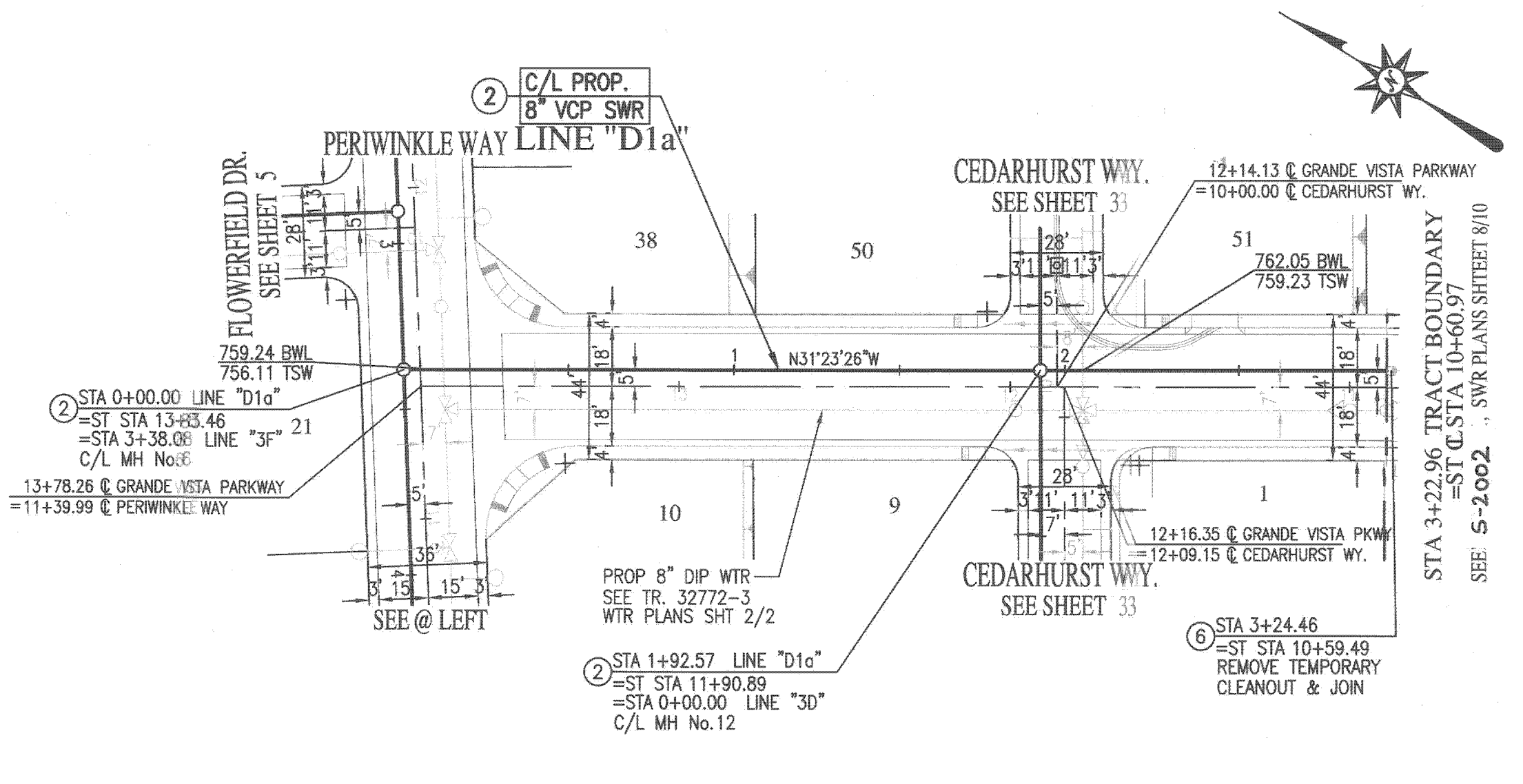
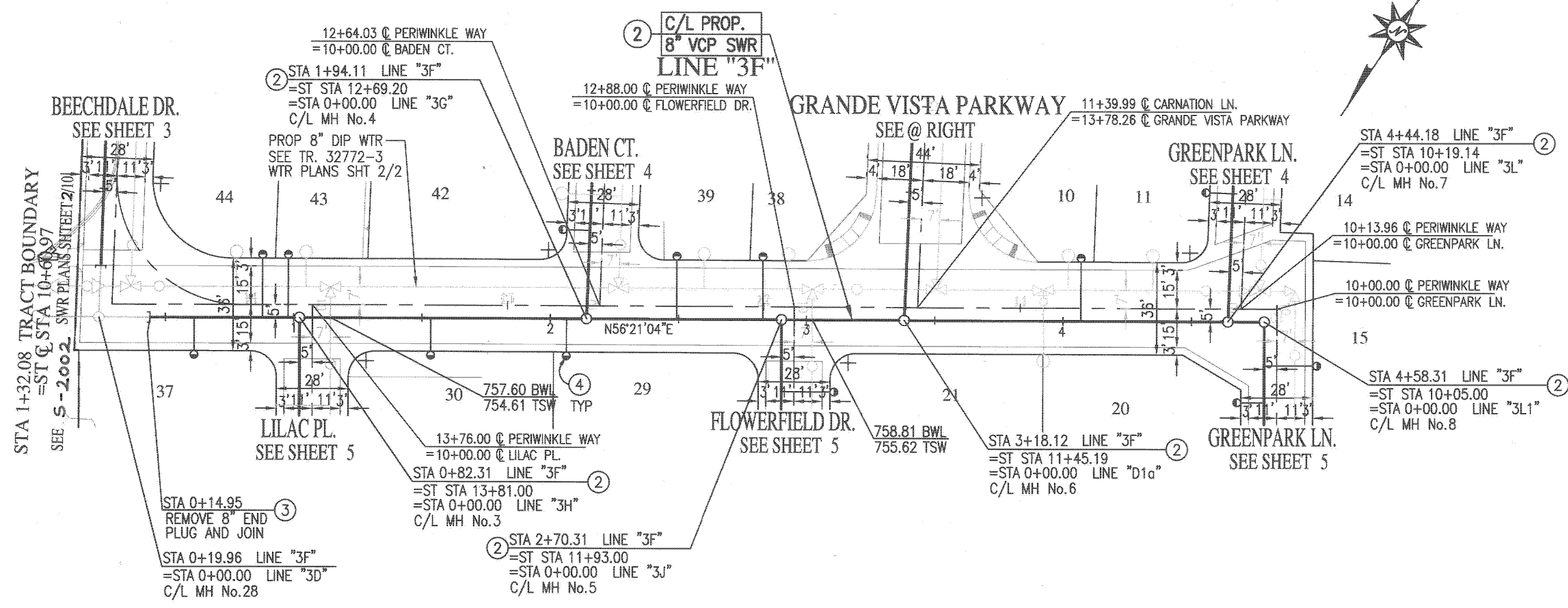

PERIWINKLE WAY

GRANDE VISTA PARKWAY

CONSTRUCTION NOTES

- 1 CONSTRUCT 8" VCP SEWER MAIN W/PIPE BEDDING CASE 1 PER C.O.R. STD. DWG. 452
- 2 CONSTRUCT 48" SEWER MANHOLE PER CITY OF RIV. STD. DWG No. 500.
- 3 REMOVE 8" END PLUG AND JOIN
- 4 CONSTRUCT 4" SEWER LATERAL WITH CLEANOUT PER CITY RIV. STD. DWG. No. 562A
- 5 INSTALL 4" BACKWATER VALVE
- 6 REMOVE TEMP. SEWER CLEANOUT AND JOIN

PUBLIC UTILITIES DEPARTMENT
WATER DIVISION

APPROVED BY: *[Signature]* DATE: 11/2/07

Underground Service Alert
Call: TOLL FREE
1 - 800
227-2600
TWO WORKING DAYS BEFORE YOU DIG

PRIVATE ENGINEERING NOTE

CONSTRUCTION CONTRACTOR AGREES THAT IN ACCORDANCE WITH GENERALLY ACCEPTED CONSTRUCTION PRACTICES, CONSTRUCTION CONTRACTOR WILL BE REQUIRED TO ASSUME SOLE AND COMPLETE RESPONSIBILITY FOR JOB SITE CONDITIONS DURING THE COURSE OF CONSTRUCTION OF THE PROJECT, INCLUDING SAFETY OF ALL PERSONS AND PROPERTY; THAT THIS REQUIREMENT SHALL BE MADE TO APPLY CONTINUOUSLY AND NOT BE LIMITED TO NORMAL WORKING HOURS, AND CONSTRUCTION CONTRACTOR PARTNER AGREES TO DEFEND, INDEMNIFY AND HOLD DESIGN PROFESSIONAL HARMLESS FROM ANY AND ALL LIABILITY, REAL OR ALLEGED, IN CONNECTION WITH THE PERFORMANCE OF WORK ON THIS PROJECT, EXCEPTING LIABILITY ARISING FROM THE SOLE NEGLIGENCE OF DESIGN PROFESSIONAL.

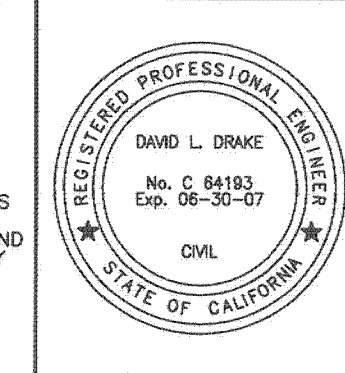

PREPARED UNDER THE DIRECTION OF:

PLANS PREPARED BY:

PSOMAS

2010 Iowa Avenue Suite 101 Riverside, CA 92507
(951) 787-8421 Fax (951) 682-3379
CITY OF RIVERSIDE TAX CERT NO: 69372 EXP: 4-07-07

SCALE: AS SHOWN
BENCH MARK: E2-P2 CHISELED SQUARE ON THE TOP OF CURB AT THE WESTERLY END OF A CATCH BASIN FRONTING THE SOUTHERLY CURB OF INDIANA AVE. AT THE SOUTHEAST CORNER OF INDIANA AVENUE AND FILLMORE STREET. ELEV=738.410

DATE: NOVEMBER 2006
DESIGNED BY: DD DRAWN BY: CA CHECKED BY: [Signature]

MARK	REVISIONS	APPR.	DATE

CITY OF RIVERSIDE, CALIFORNIA
DEPARTMENT OF PUBLIC WORKS

APPROVED BY: *[Signature]* DATE: 11/5/07
PRINCIPAL ENGR. CITY ENGINEER

IN THE CITY OF RIVERSIDE, CALIFORNIA
TRACT 32772-3
SEWER IMPROVEMENT PLAN
LINE "3F" STA 1+32.08 TO STA 4+78.27
LINE "D1a" STA 00+00.00 TO STA 3+24.46

FOR: GRIFFIN INDUSTRIES

PW06-0482
S-2004
SHEET 2 OF 5
FILE NO.: 1104-007

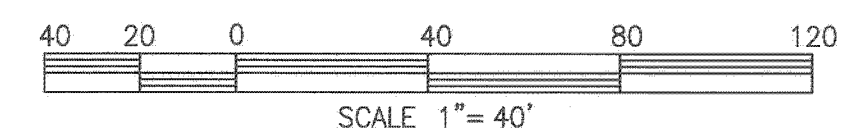

WDID: 8 33C334294

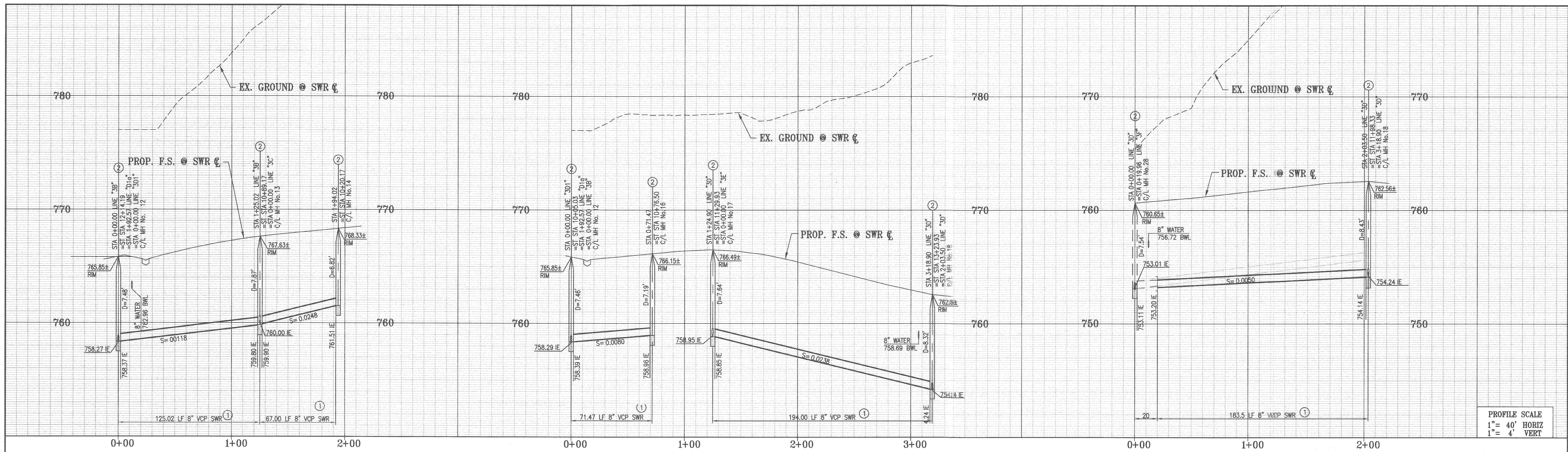

PROFILE SCALE
1" = 40' HORIZ
1" = 4' VERT

LINE "3B"

LINE "3D1"

LINE "3D"

LINE "3D"

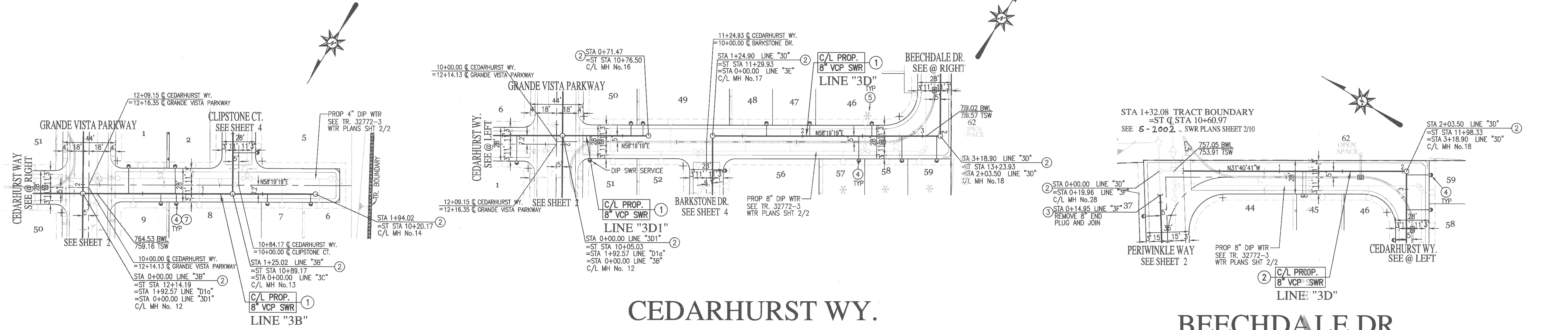

CEDARHURST WY.

CEDARHURST WY.

BEECHDALE DR.

PUBLIC UTILITIES DEPARTMENT
WATER DIVISION

APPROVED BY: *[Signature]* 11/2/07
DATE

Underground Service Alert
Call: TOLL FREE
1 - 800
227-2600
TWO WORKING DAYS BEFORE YOU DIG

PRIVATE ENGINEERING NOTE
CONSTRUCTION CONTRACTOR AGREES THAT IN ACCORDANCE WITH GENERALLY ACCEPTED CONSTRUCTION PRACTICES, CONSTRUCTION CONTRACTOR WILL BE REQUIRED TO ASSUME SOLE AND COMPLETE RESPONSIBILITY FOR JOB SITE CONDITIONS DURING THE COURSE OF CONSTRUCTION OF THE PROJECT, INCLUDING SAFETY OF ALL PERSONS AND PROPERTY, THAT THE REQUIREMENT SHALL BE MADE TO APPLY CONTINUOUSLY AND NOT BE LIMITED TO NORMAL WORKING HOURS, AND CONSTRUCTION CONTRACTOR FURTHER AGREES TO DEFEND, INDEMNIFY AND HOLD DESIGN PROFESSIONAL HARMLESS FROM ANY AND ALL LIABILITY, REAL OR ALLEGED, IN CONNECTION WITH THE PERFORMANCE OF WORK ON THIS PROJECT, EXCEPTING LIABILITY ARISING FROM THE SOLE NEGLIGENCE OF DESIGN PROFESSIONAL.

PREPARED UNDER THE DIRECTION OF:
[Signature]
REGISTERED CIVIL ENGINEER No. C 64193
EXPIRATION DATE: 06-30-07 DATE: 1-2-07

PLANS PREPARED BY:
PSOMAS
2010 Iowa Avenue Suite 101 Riverside, CA 92507
(951) 787-8421 Fax (951) 682-3379
CITY OF RIVERSIDE TAX CERT NO: 69372 EXP: 4-07-07
SCALE: AS SHOWN
BENCH MARK: E2-P2 CHISELED SQUARE ON THE TOP OF CURB AT THE WESTERLY END OF A CATCH BASIN FRONTING THE SOUTHERLY CURB OF INDIANA AVE. AT THE SOUTHEAST CORNER OF INDIANA AVENUE AND FILLMORE STREET. ELEV=738.410
DATE: NOVEMBER 2006

- CONSTRUCTION NOTES**
- CONSTRUCT 8" VCP SEWER MAIN W/PIPE BEDDING CASE I PER C.O.R. STD. DWG. 452
 - CONSTRUCT 48" SEWER MANHOLE PER CITY OF RIV. STD. DWG No. 500.
 - REMOVE 8" END PLUG AND JOIN
 - CONSTRUCT 4" SEWER LATERAL WITH CLEANOUT PER CITY RIV. STD. DWG. No. 562A
 - INSTALL 4" BACKWATER VALVE

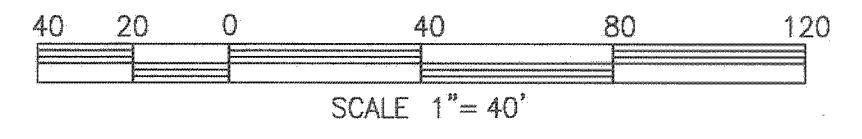

CITY OF RIVERSIDE, CALIFORNIA
DEPARTMENT OF PUBLIC WORKS
APPROVED BY: *[Signature]*
PRINCIPAL ENGR. DATE: 11/5/07

IN THE CITY OF RIVERSIDE, CALIFORNIA
TRACT 32772-3
SEWER IMPROVEMENT PLAN
LINE "3B" STA 00+00.00 TO STA 1+94.02
LINE "3D1" STA 00+00.00 TO STA 3+18.90
LINE "3D" STA 00+00.00 TO STA 2+03.50
FOR: GRIFFIN INDUSTRIES

PW06-0482
S-2004
SHEET 3 OF 5
FILE NO.: 1104-007

INDEXED 1-26-07 *[Signature]*

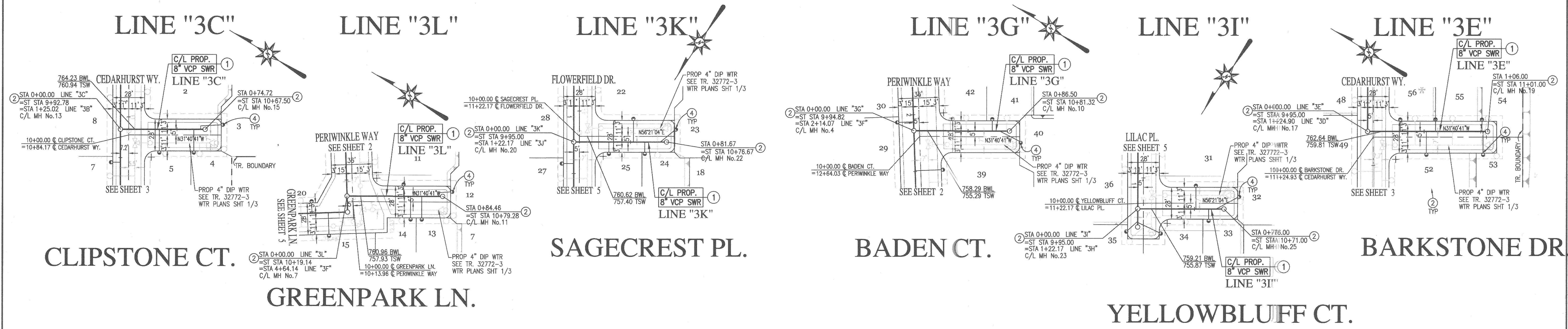
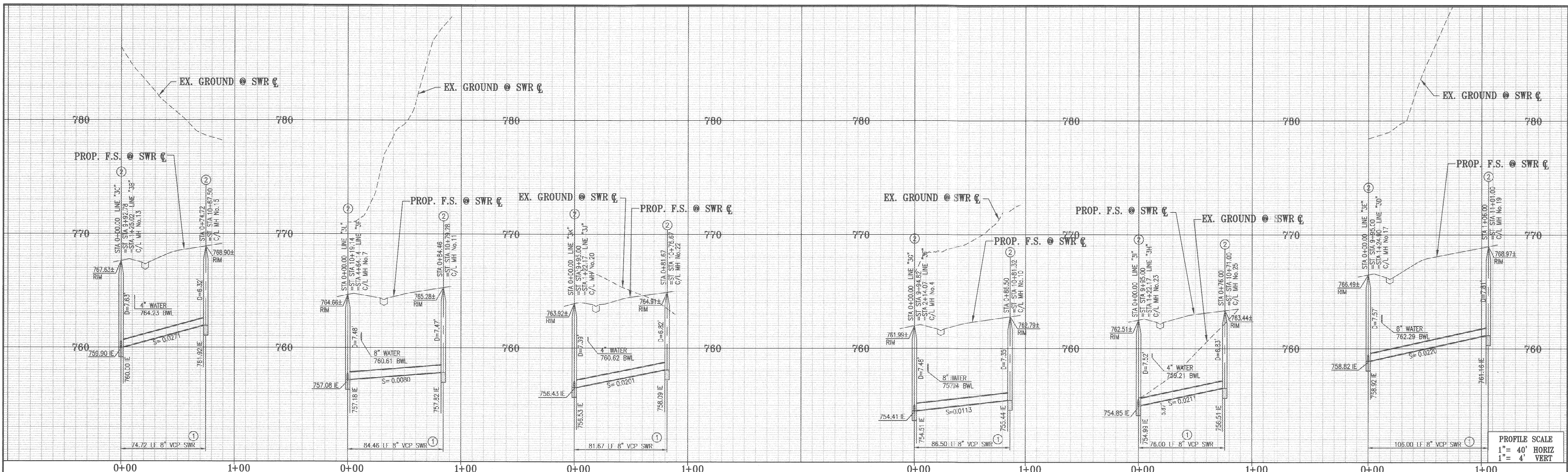

PUBLIC UTILITIES DEPARTMENT
WATER DIVISION

Amell 1/2/07
APPROVED BY DATE

- CONSTRUCTION NOTES**
- 1) CONSTRUCT 8" VCP SEWER MAIN W/PIPE BEDDING CASE I PER C.O.R. STD. DWG. 452
 - 2) CONSTRUCT 48" SEWER MANHOLE PER CITY OF RIV. STD. DWG No. 500.
 - 4) CONSTRUCT 4" SEWER LATERAL WITH CLEANOUT PER CITY RIV. STD. DWG. No. 562A
 - 5) INSTALL 4" BACKWATER VALVE

PRIVATE ENGINEERING NOTE

CONSTRUCTION CONTRACTOR AGREES THAT IN ACCORDANCE WITH GENERALLY ACCEPTED CONSTRUCTION PRACTICES, CONSTRUCTION CONTRACTOR WILL BE REQUIRED TO ASSUME SOLE AND COMPLETE RESPONSIBILITY FOR JOB SITE CONDITIONS DURING THE COURSE OF CONSTRUCTION OF THE PROJECT, INCLUDING SAFETY OF ALL PERSONS AND PROPERTY. THAT THIS REQUIREMENT SHALL BE MADE TO APPLY CONTINUOUSLY AND NOT BE LIMITED TO NORMAL WORKING HOURS, AND CONSTRUCTION CONTRACTOR FURTHER AGREES TO DEFEND, INDEMNIFY AND HOLD DESIGN PROFESSIONAL HARMLESS FROM ANY AND ALL LIABILITY, REAL OR ALLEGED, IN CONNECTION WITH THE PERFORMANCE OF WORK ON THIS PROJECT, EXCEPTING LIABILITY ARISING FROM THE SOLE NEGLIGENCE OF DESIGN PROFESSIONAL.

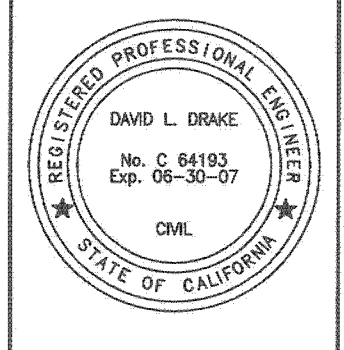

PREPARED UNDER THE DIRECTION OF:

[Signature]

REGISTERED CIVIL ENGINEER NO. C 84193
EXPIRATION DATE: 08-30-07 DATE: 1-2-07

PLANS PREPARED BY:

PSOMAS

2010 Iowa Avenue Suite 101 Riverside, CA 92507
(951) 787-8421 Fax (951) 682-3379
CITY OF RIVERSIDE TAX CERT NO: 69372 EXP: 4-07-07

SCALE: AS SHOWN

BENCH MARK: E2-P2 CHISELED SQUARE ON THE TOP OF CURB AT THE WESTERLY END OF A CATCH BASIN FRONTING THE SOUTHERLY CURB OF INDIANA AVE. AT THE SOUTHEAST CORNER OF INDIANA AVENUE AND FILLMORE STREET. ELEV=738.410

DATE: NOVEMBER 2006

MARK	REVISIONS	APPR.	DATE

DESIGNED BY: DD DRAWN BY: CA CHECKED BY: _____

CITY OF RIVERSIDE, CALIFORNIA
DEPARTMENT OF PUBLIC WORKS

APPROVED BY: *[Signature]* DATE: 1/5/07
PRINCIPAL ENGR.

APPROVED BY: *[Signature]* DATE: 1/5/07
CITY ENGINEER

IN THE CITY OF RIVERSIDE, CALIFORNIA
TRACT 32772-3
SEWER IMPROVEMENT PLAN

LINE "3C" STA 0+00.00 TO STA 1+94.02
LINE "3L" STA 0+00.00 TO STA 1+74.28
LINE "3K" STA 0+00.00 TO STA 6+00.00
LINE "3G" STA 0+00.00 TO STA 1+94.02
LINE "3I" STA 0+00.00 TO STA 1+74.28
LINE "3E" STA 0+00.00 TO STA 6+00.00

FOR: GRIFFIN INDUSTRIES

PW06-0482
S-2004
SHEET 4
FILE NO.: 1104-007

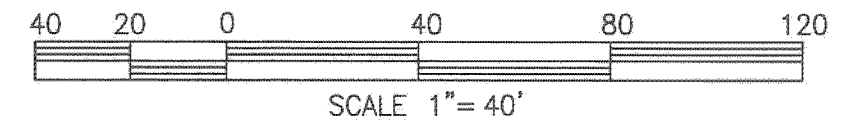

WDID: 8 33C334294

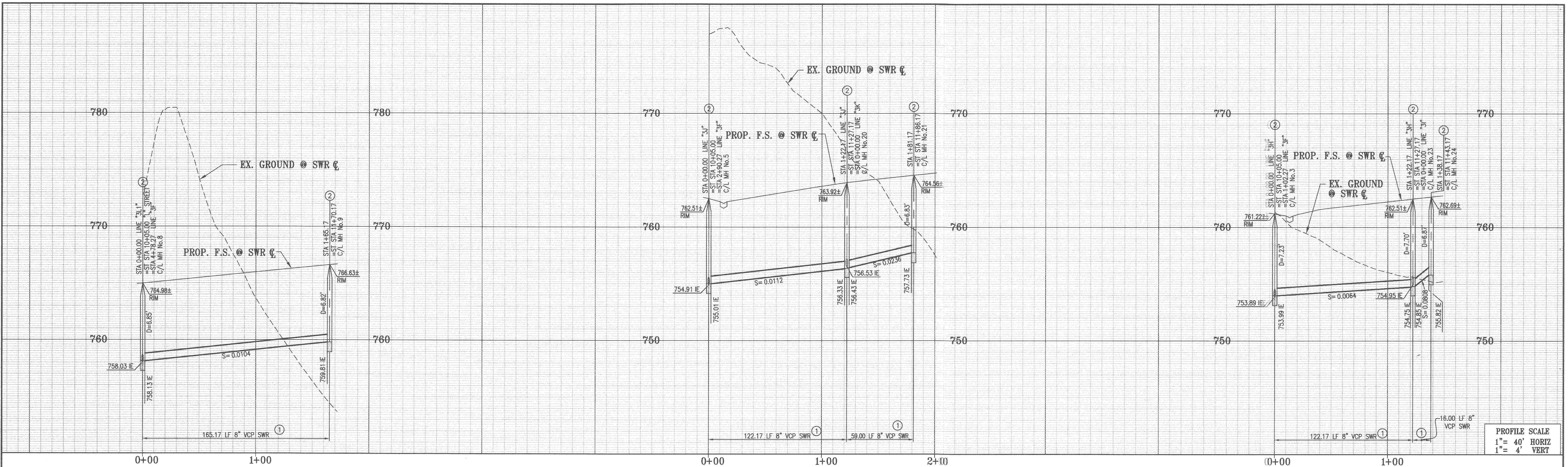

PROFILE SCALE
1" = 40' HORIZ
1" = 4' VERT

LINE "3L1"

LINE "3J"

LINE "3H"

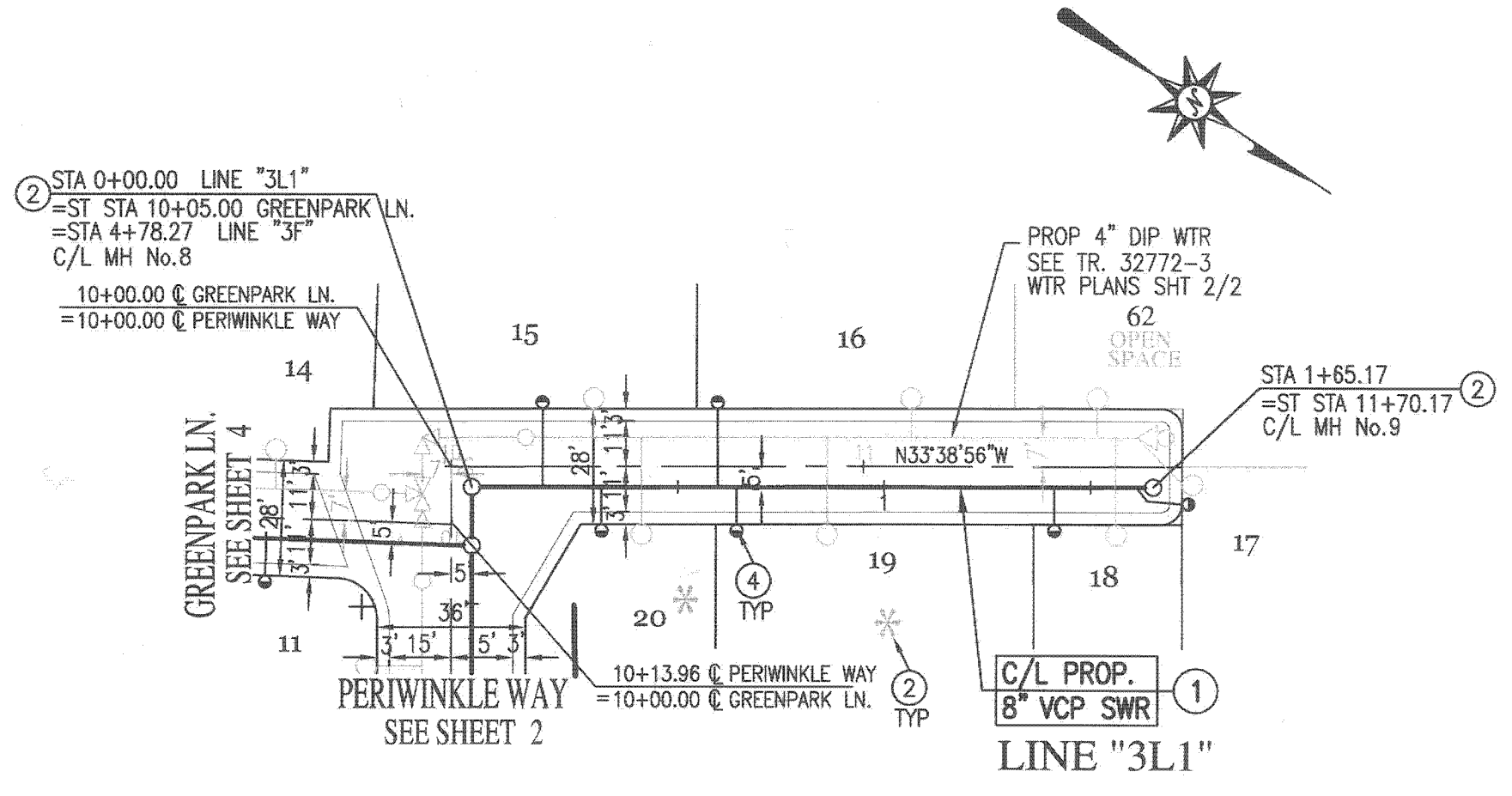

GREENPARK LN.

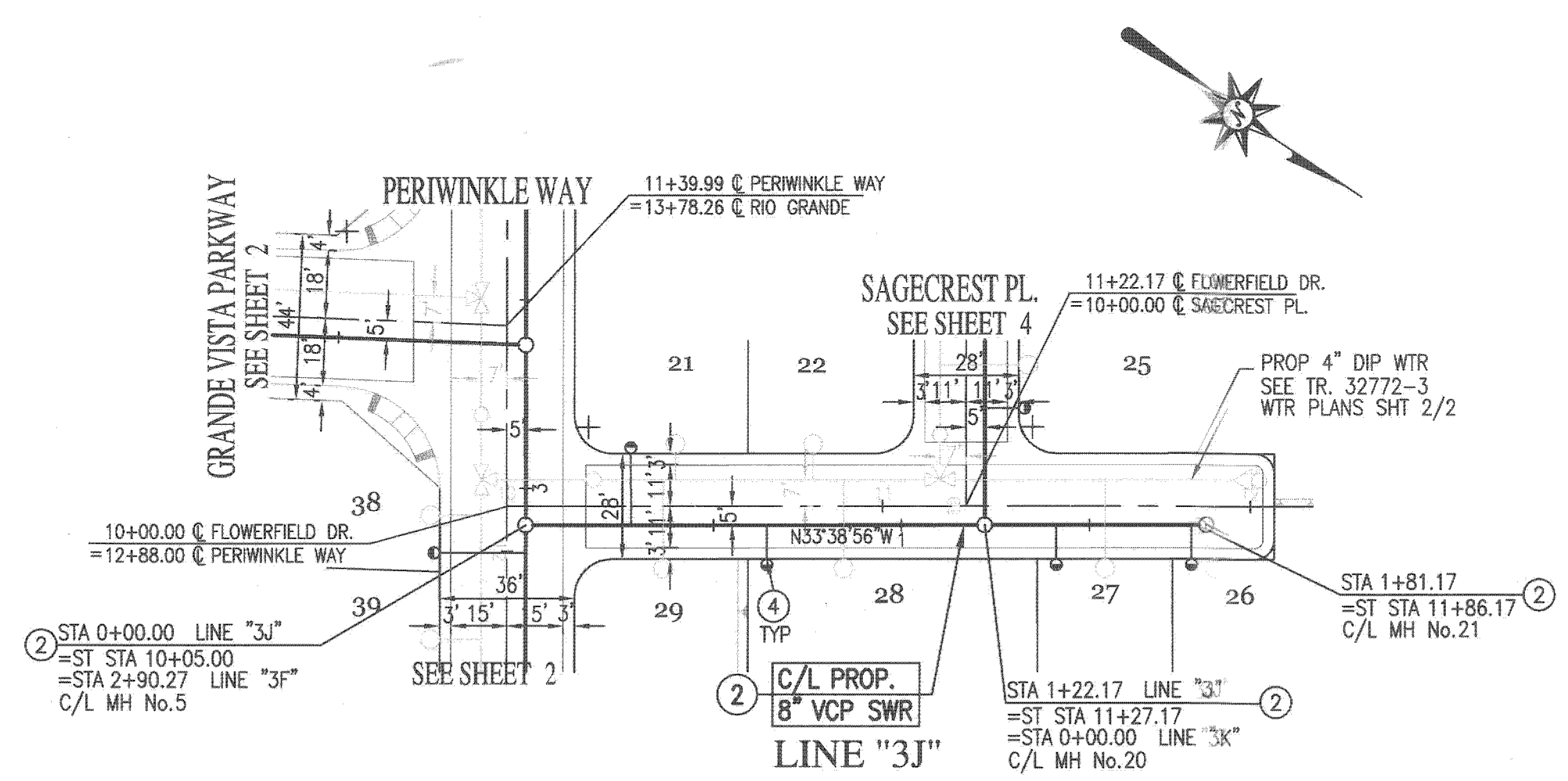

FLOWERFIELD DR.

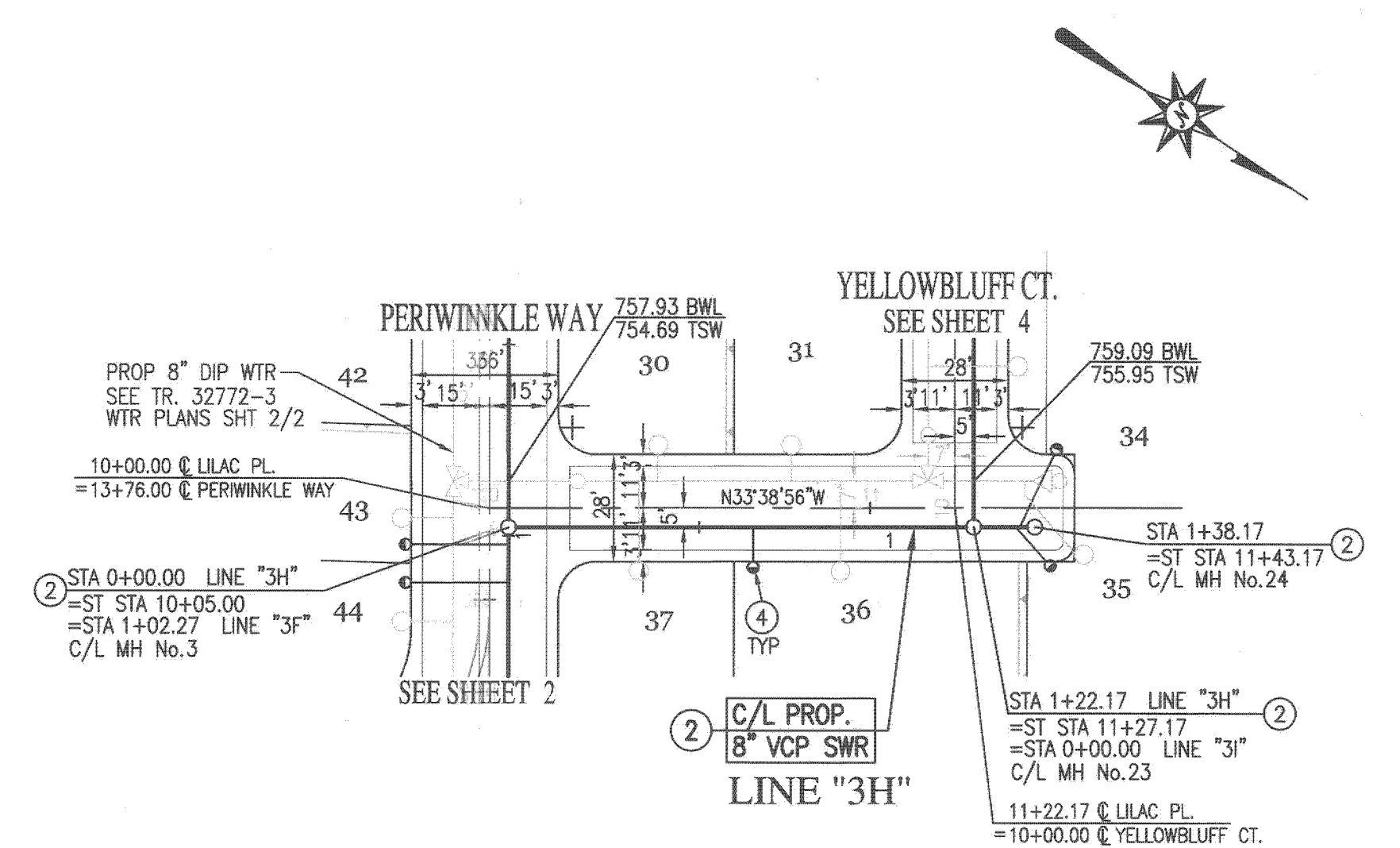

LILAC PL.

- CONSTRUCTION NOTES**
- CONSTRUCT 8" VCP SEWER MAIN W/PIPE BEDDING CASE 1 PER C.O.R. STD. DWG. 452
 - CONSTRUCT 48" SEWER MANHOLE PER CITY OF RIV. STD. DWG No. 500.
 - CONSTRUCT 4" SEWER LATERAL WITH CLEANOUT PER CITY RIV. STD. DWG. No. 562A
 - INSTALL 4" BACKWATER VALVE

PUBLIC UTILITIES DEPARTMENT
WATER DIVISION

APPROVED BY: *[Signature]* DATE: 11/2/07

Underground Service Alert
Call: TOLL FREE
1 - 800
227-2600
TWO WORKING DAYS BEFORE YOU DIG

PRIVATE ENGINEERING NOTE

CONSTRUCTION CONTRACTOR AGREES THAT IN ACCORDANCE WITH GENERALLY ACCEPTED CONSTRUCTION PRACTICES, CONSTRUCTION CONTRACTOR WILL BE REQUIRED TO ASSUME SOLE AND COMPLETE RESPONSIBILITY FOR JOB SITE CONDITIONS DURING THE COURSE OF CONSTRUCTION OF THE PROJECT, INCLUDING SAFETY OF ALL PERSONS AND PROPERTY; THAT THIS REQUIREMENT SHALL BE MADE TO APPLY CONTINUOUSLY AND NOT BE LIMITED TO NORMAL WORKING HOURS, AND CONSTRUCTION CONTRACTOR AGREES TO DEFEND, INDEMNIFY AND HOLD DESIGN PROFESSIONAL HARMLESS FROM ANY AND ALL LIABILITY, REAL OR ALLEGED, IN CONNECTION WITH THE PERFORMANCE OF WORK ON THIS PROJECT, EXCEPTING LIABILITY ARISING FROM THE SOLE NEGLIGENCE OF DESIGN PROFESSIONAL.

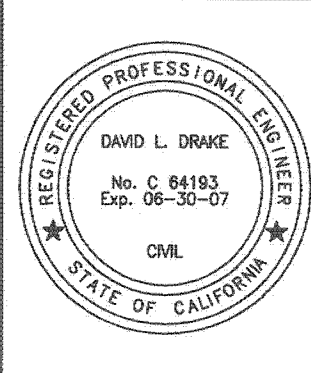

PREPARED UNDER THE DIRECTION OF:
[Signature]
REGISTERED CIVIL ENGINEER NO. C 64193
EXPIRATION DATE: 06-30-07 DATE: 1-2-09

PLANS PREPARED BY:
PSOMAS
2010 Iowa Avenue Suite 101 Riverside, CA 92507
(951) 787-8421 Fax (951) 682-3379
CITY OF RIVERSIDE TAX CERT NO: 69372 EXP: 4-07-07
SCALE: AS SHOWN
BENCH MARK: E2-P2 CHISELED SQUARE ON THE TOP OF CURB AT THE WESTERLY END OF A CATCH BASIN FRONTING THE SOUTHERLY CURB OF INDIANA AVE. AT THE SOUTHEAST CORNER OF INDIANA AVENUE AND FILLMORE STREET. ELEV=738.410
DATE: NOVEMBER 2006

MARK	REVISIONS	APPR.	DATE

DESIGNED BY: DD DRAWN BY: CA CHECKED BY: _____

CITY OF RIVERSIDE, CALIFORNIA
DEPARTMENT OF PUBLIC WORKS

APPROVED BY: *[Signature]* DATE: 11/2/07
PRINCIPAL ENGR. CITY ENGINEER

IN THE CITY OF RIVERSIDE, CALIFORNIA
TRACT 32772-3
SEWER IMPROVEMENT PLAN
LINE "3L" STA 0+00.00 TO STA 1+65.17
LINE "3J" STA 0+00.00 TO STA 1+81.17
LINE "3H" STA 0+00.00 TO STA 1+38.17
FOR: GRIFFIN INDUSTRIES

PW06-0482
S-2004
SHEET 5 OF 5
FILE NO.: 1104-007

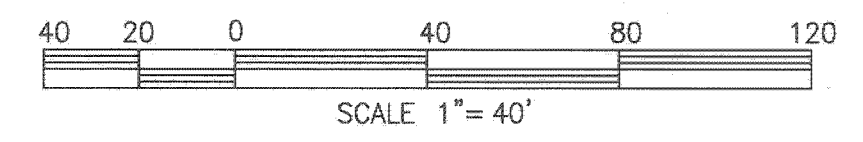

WDID: 8 33C334294

INDEXED 1-26-07