

**CONSTRUCTION LEGEND**

- 
- 

**CONSTRUCTION NOTES**

- NUMBERS ABOVE 100 IN A HEXAGON ON THE PLAN REFER TO THE RESPECTIVE STANDARD DRAWING AND SHALL BE CONSTRUCTED ACCORDINGLY, UNLESS MODIFICATIONS ARE NOTED ON THE PLAN OR COVER SHEET. ANY NUMBER SHOWN BELOW THE STANDARD DRAWING NUMBER INDICATES THE SPECIFIC ALTERNATE TO BE CONSTRUCTED.
- EXISTING UTILITIES SHOWN ON THIS PLAN ARE PLOTTED FROM UTILITY RECORDS. THE CONTRACTOR IS REQUIRED TO TAKE DUE PRECAUTIONARY MEASURES TO LOCATE AND PROTECT ALL UTILITIES, WHETHER OR NOT SHOWN ON THIS PLAN. IF THE COVER OF A UTILITY IS KNOWN, IT IS SHOWN IN THE PROFILE. UTILITIES IN THE PROFILE AS INDICATES THAT THE COVER IS UNKNOWN, BUT THE UTILITY IS NOT EXPECTED TO CONFLICT WITH THE PROPOSED IMPROVEMENTS.
- ALL ELEVATIONS SHOWN ON THE PLANS SHALL BE STAKED IN THE FIELD.
- PRIME CONTRACTORS BIDDING THIS WORK SHALL HAVE A CLASS A OR "C-B" LICENSE.
- RIGHTS OF ENTRY HAVE BEEN OBTAINED FOR WORK SHOWN OUTSIDE OF CITY RIGHT-OF-WAY.
- STRIPING AND PAVEMENT MARKINGS SHALL BE REPAINTED BY CITY FORCES AFTER PAVING OPERATIONS.

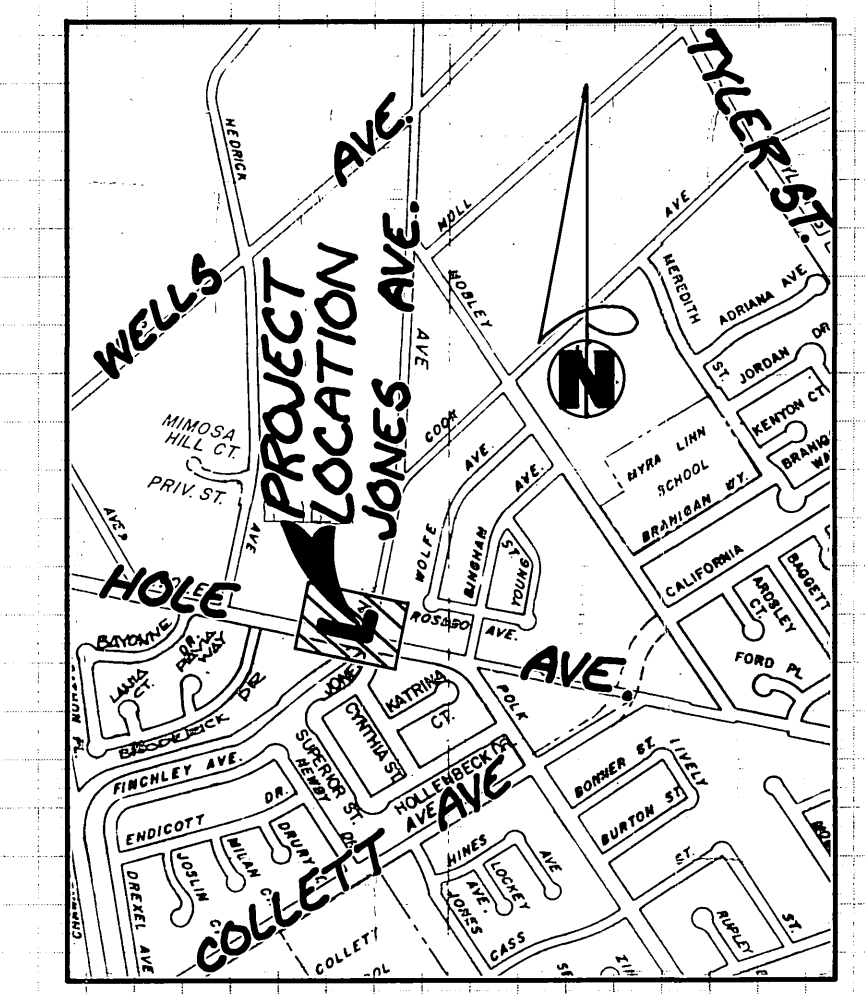
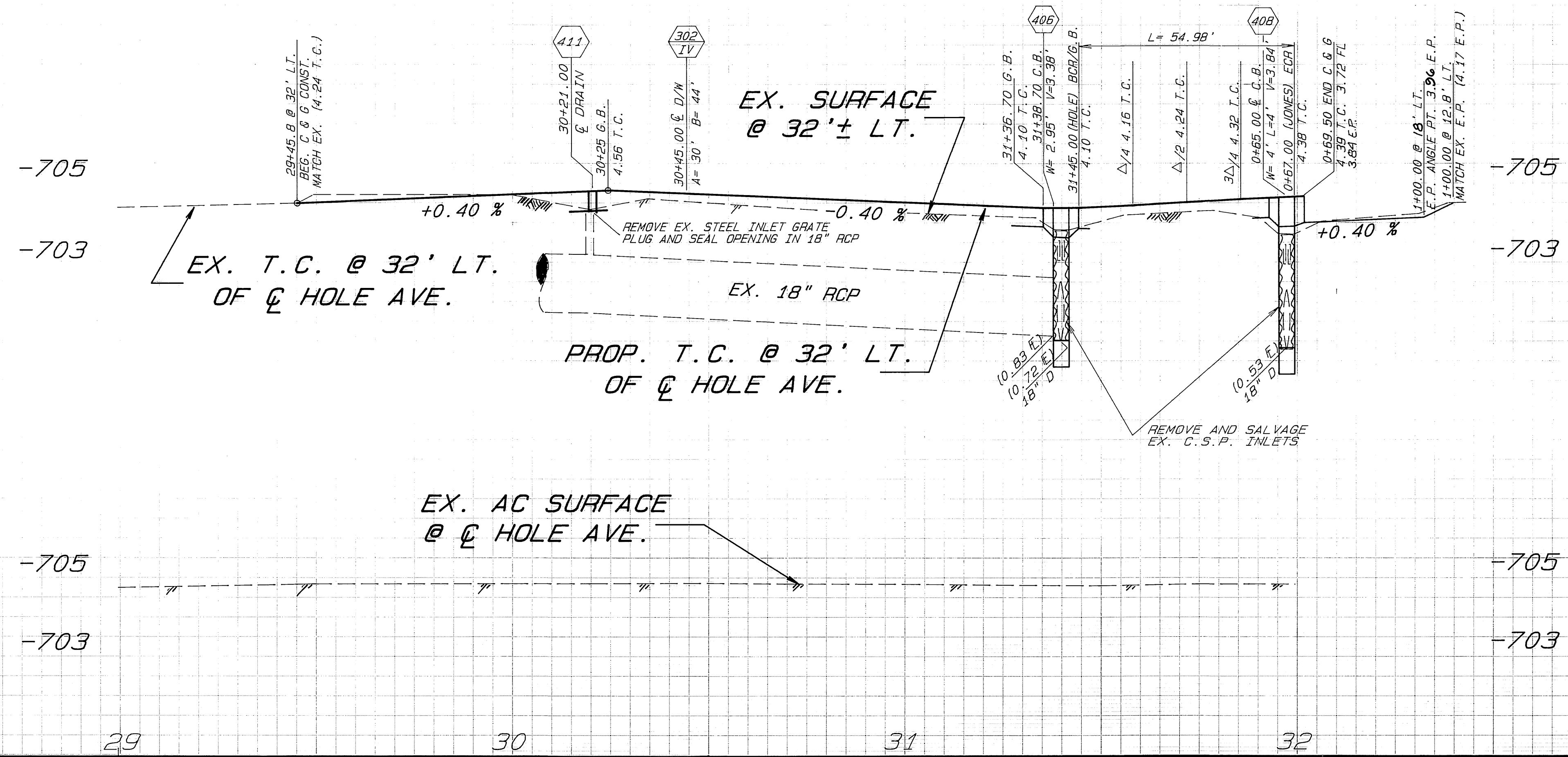

**PROJECT LOCATION MAP**  
SCALE: 1" = 100'

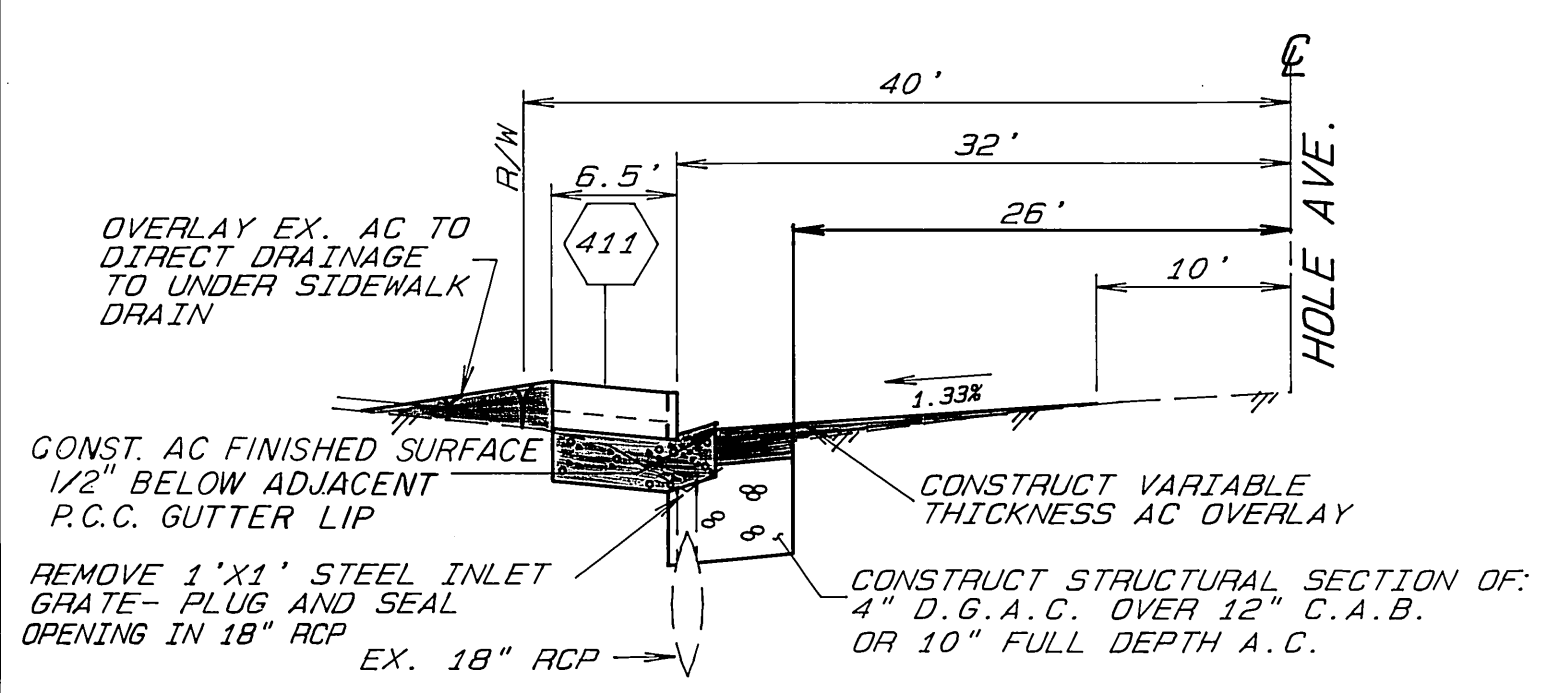

**SECT. A-A**  
UNDER SIDEWALK DRAIN DETAIL  
FOR PARKING LOT DRAINAGE  
SCALE: HORIZ. 1" = 10'  
VERT. 1" = 2'

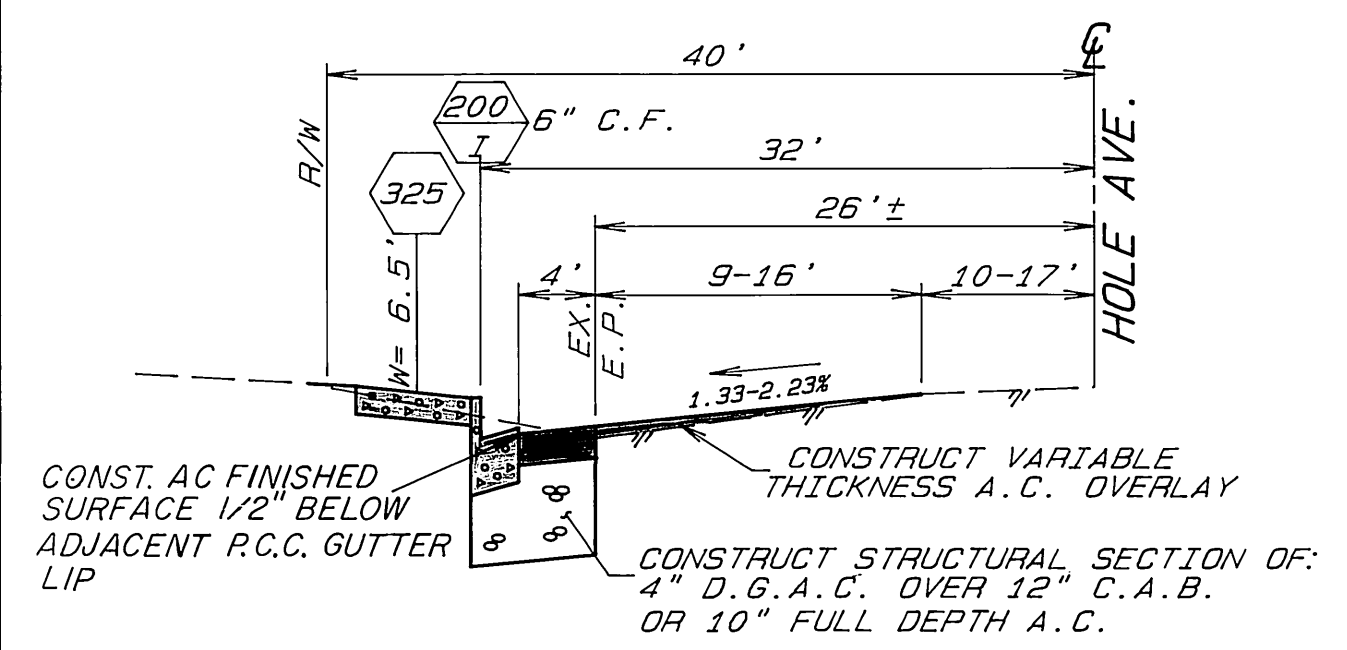

**TYP. SECT. HOLE AVE.**  
STA. 29+50 TO 31+45  
SCALE: HORIZ. 1" = 10'  
VERT. 1" = 2'

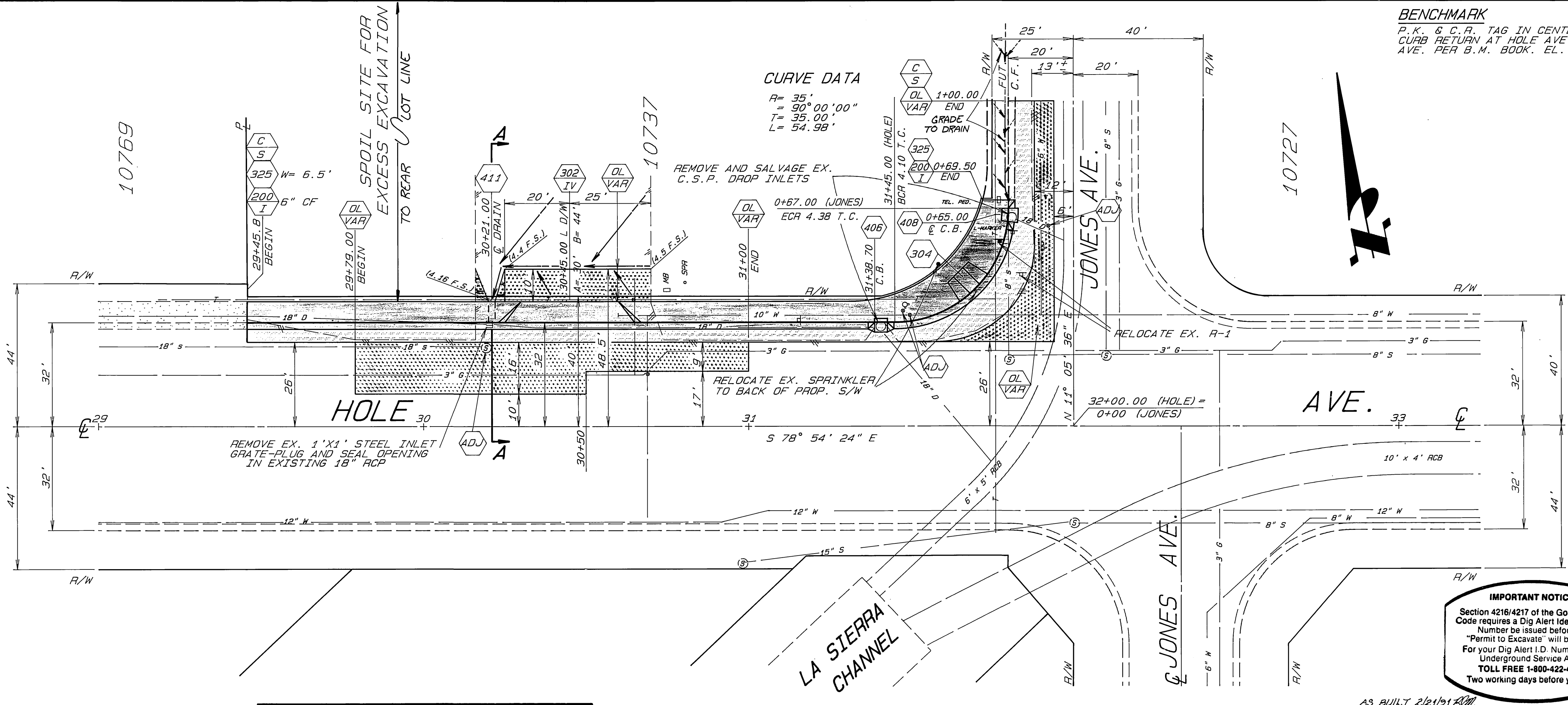

**BENCHMARK**  
P.K. & C.R. TAG IN CENTER OF S/W CURB RETURN AT HOLE AVE. & JONES AVE. PER B.M. BOOK. EL. 703.973

**IMPORTANT NOTICE**  
Section 4216/4217 of the Government Code requires a Dig Alert Identification Number be issued before a "Permit to Excavate" will be valid. For your Dig Alert I.D. Number Call Underground Service Alert TOLL FREE 1-800-422-4133 Two working days before you dig

**ENGINEER IN RESPONSIBLE CHARGE**  
Ronald C. Mueller  
RONALD C. MUELLER  
R.C.E. 29510 expires 3-31-91  
DATE 4-6-89

**CITY OF RIVERSIDE**  
PUBLIC WORKS DEPARTMENT

APPROVED BY	DATE	BY	APPROVED BY
CHIEF P.W. ENGINEER	4-5-89	[Signature]	Barry Bell
CHIEF P.W. INSPECTOR	3-21-89	[Signature]	PUBLIC WORKS DIRECTOR
SURVEYOR	3-21-89	[Signature]	
TRAFFIC DIVISION	3-25-89	[Signature]	
PARK DEPARTMENT			

DESIGNED BY RVZ DRAWN BY RVZ CHECKED BY PCW DATE 4/5/89

**HOLE AVE. WIDENING**  
JONES ST. TO 250'± W'LY

ACCOUNT NO. 30-575-257-30  
**R-3017**  
SHEET 1 OF 1  
HORIZ. SCALE: 1" = 20' VERT. SCALE: 1" = 2'  
INDEXED 5-18-89