

INDEX OF SHEETS

SHEET NO.	T-1	TITLE
SHEET NO.	D-1	DEMOLITION PLAN
SHEET NO.	D-2	DEMOLITION PLAN
SHEET NO.	D-3	DEMOLITION PLAN
SHEET NO.	I-1	IRRIGATION PLAN
SHEET NO.	I-2	IRRIGATION PLAN
SHEET NO.	I-3	IRRIGATION PLAN
SHEET NO.	IQ-1	IRRIGATION QUANTITIES
SHEET NO.	IQ-2	IRRIGATION QUANTITIES
SHEET NO.	SD-1	IRRIGATION DETAILS
SHEET NO.	P-1	PLANTING PLAN
SHEET NO.	P-2	PLANTING PLAN
SHEET NO.	P-3	PLANTING PLAN
SHEET NO.	P-4	PLANTING LIST

STATE OF CALIFORNIA  
DEPARTMENT OF TRANSPORTATION

---

**PROJECT PLANS FOR HIGHWAY PLANTING ON  
INTERSTATE HIGHWAY 91  
IN RIVERSIDE COUNTY  
IN THE CITY OF RIVERSIDE**

To be supplemented by Standard Plans dated July, 1999

DIST	COUNTY	ROUTE	KILOMETER POST TOTAL PROJECT	SHEET No	TOTAL SHEETS
08	RIV	91		1	14

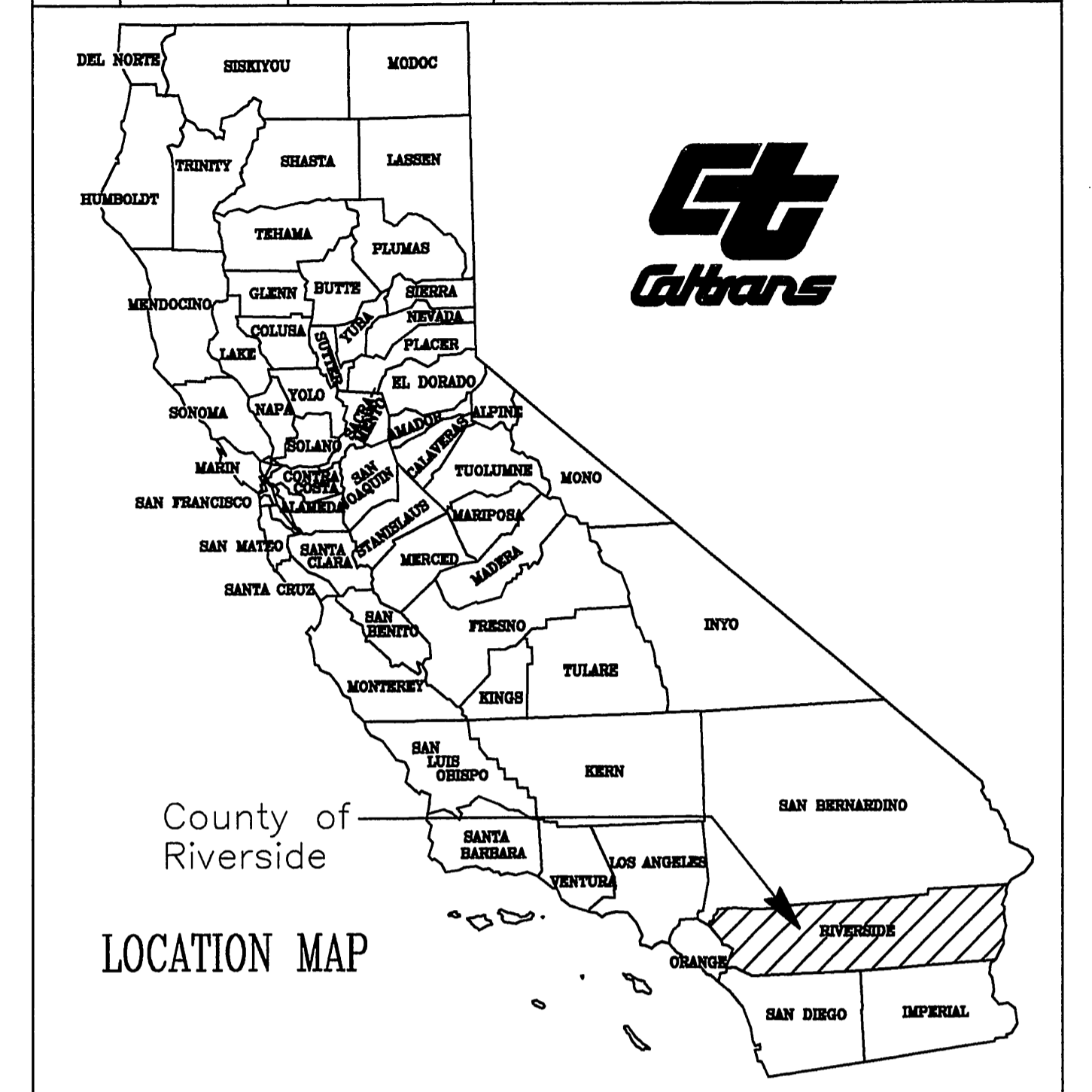

The State of California or its officers or agents shall not be responsible for the accuracy or completeness of electronic copies of this plan sheet.

To get to the Caltrans web site, go to: <http://www.dot.ca.gov>

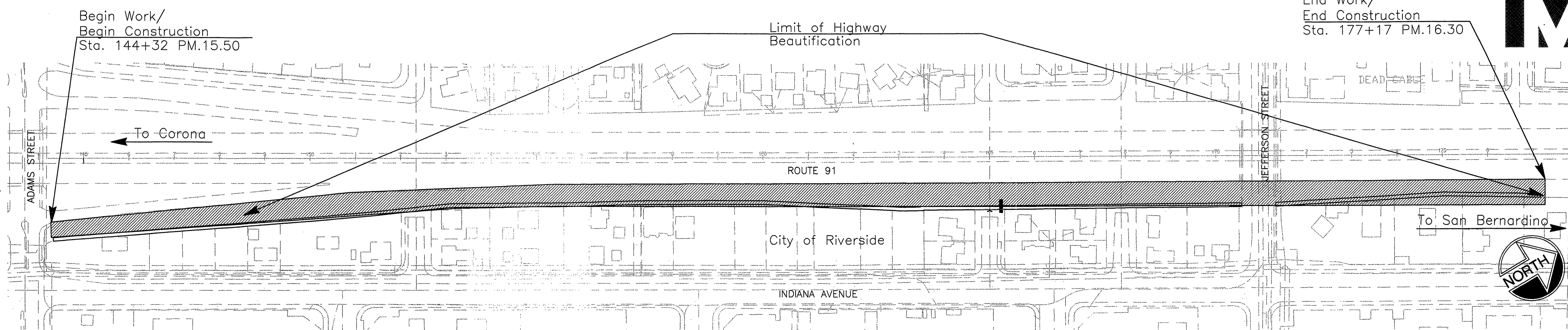

- NOTES:
- ALL WORK WITHIN STATE RIGHT OF WAY SHALL BE COMPLETED IN ACCORDANCE WITH THE CURRENT STATE OF CALIFORNIA DEPARTMENT OF TRANSPORTATION SPECIFICATIONS. SHOULD A CONFLICT ARISE BETWEEN THE CONTRACT PLANS, SPECIFICATIONS AND/OR DETAILS PREPARED BY THE PERMITTEE, THE STATE'S STANDARD SPECIFICATIONS SHALL GOVERN AS DETERMINED BY THE STATE'S REPRESENTATIVE.
  - TO BE SUPPLEMENTED BY CALTRANS STANDARD PLANS, AND STANDARD SPECIFICATIONS DATED JULY 1999

The Contractor shall possess the class (or classes) of license as specified in the "Notice to Contractors."

'NO SCALE'

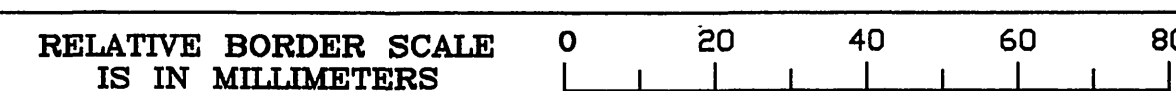

USERNAME => USER  
DGN FILE => \$REQUEST

PERMIT NUMBER	08-04-N-LF-1377	Contract No.	
---------------	-----------------	--------------	--

CU 00000 EA 00000

INDEXED 6-07-05 lft R-3842

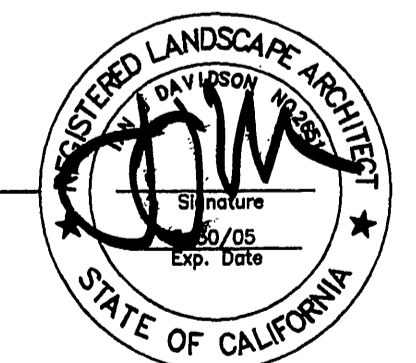
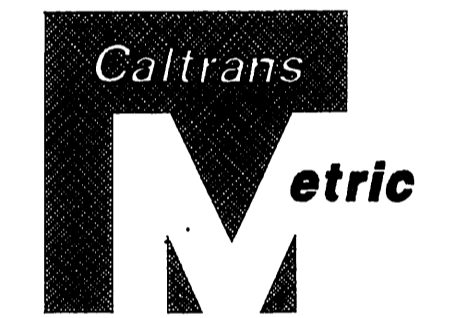

CITY APPROVAL:

APPROVED BY: *[Signature]*

CITY ENGINEER FOR THE CITY OF RIVERSIDE

DATE: 4/14/05

Licensed Landscape Architect

Plans Approval Date

Ian Davidson, Landscape Architecture  
3744 10TH STREET, SUITE 200  
RIVERSIDE, CA 92501  
951 683 1283 . FAX 951 683 4352  
E-MAIL: IDAVIDSON@DLAINC.COM  
REGISTRATION NO. 2651

APR 08, 2005 - 11:44am sseidman J:\Drawings\Landscape\10704CV.dwg DATE PLOTTED -> 00-00-00

STATE OF CALIFORNIA - DEPARTMENT OF TRANSPORTATION  
**Caltrans** LANDSCAPE ARCHITECTURE  
 PROJECT LANDSCAPE ARCHITECT  
**IAN DAVIDSON LANDSCAPE ARCHITECTURE**  
 3744 TENTH STREET, SUITE 200, STREET, RIVERSIDE, CA 92504  
 (951) 985-1285 (951) 985-8322 FAX



DIST	COUNTY	ROUTE	POST MILE PROJECT	TOTAL SHEET No	TOTAL SHEETS
08	Riv	91	-	2	14

LICENSED LANDSCAPE ARCHITECT

PLANS APPROVAL DATE

The State of California or its officers or agents shall not be responsible for the accuracy or completeness of electronic copies of this plan sheet.

Cal-Trans now has a web site! To get to the web site, go to: <http://tresp.dot.ca.gov>

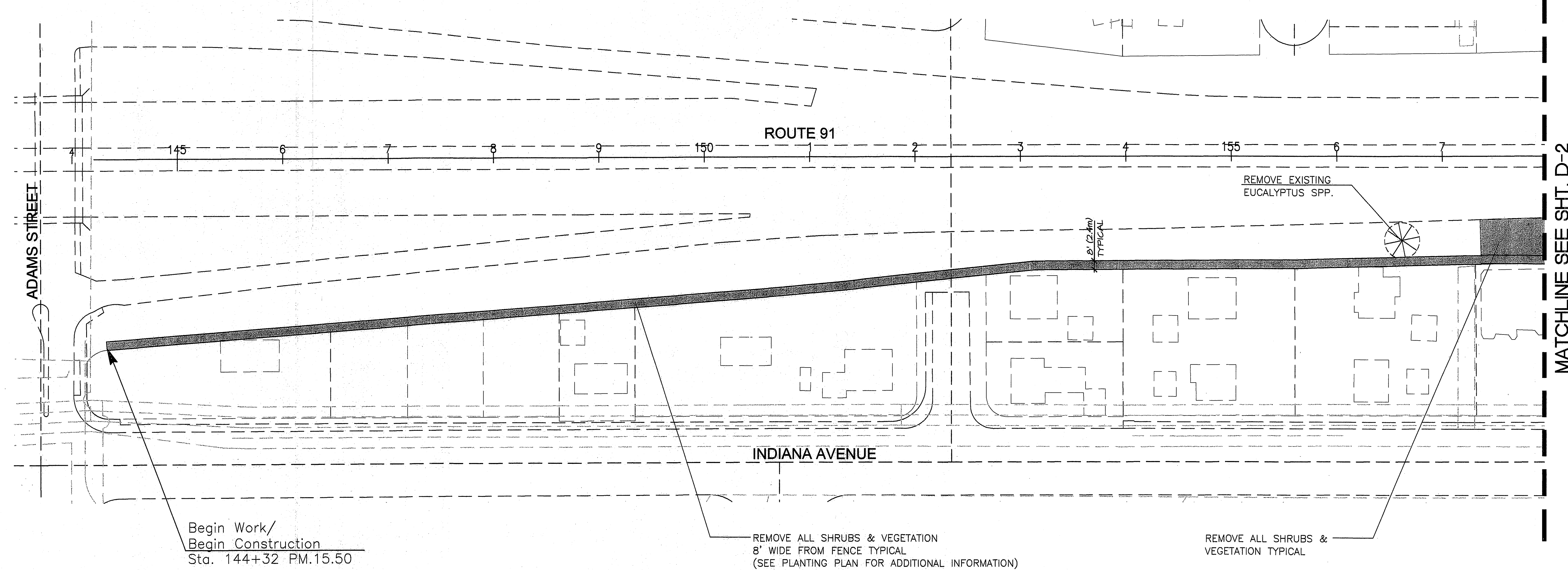
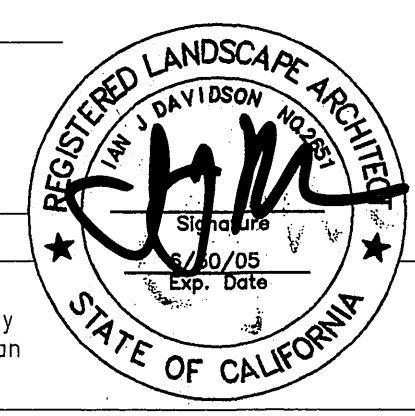

Begin Work/  
 Begin Construction  
 Sta. 144+32 PM.15.50

REMOVE ALL SHRUBS & VEGETATION  
 8' WIDE FROM FENCE TYPICAL  
 (SEE PLANTING PLAN FOR ADDITIONAL INFORMATION)

REMOVE ALL SHRUBS &  
 VEGETATION TYPICAL

MATCHLINE SEE SHT. D-2



**DEMOLITION PLAN**  
 SCALE = 1:50/1:500  
 D-1  
 PERMIT NUMBER 08-04-N-LF-1377

FOR REDUCED PLANS ORIGINAL SCALE IS IN MILLIMETERS

USERNAME:  
 DGN FILE:

CU FED. EA NO.

EA STATE NO.

INDEXED 06-07-05 KH

R-3842

DATE PLOTTED: Apr 06, 2005 - 12:36pm  
 TIME PLOTTED: J:\2004\10704 - Route 91\Drawings\Landscape\10704DM.dwg  
 LAST REVISION: sseidman

STATE OF CALIFORNIA - DEPARTMENT OF TRANSPORTATION  
**Caltrans** LANDSCAPE ARCHITECTURE  
 PROJECT LANDSCAPE ARCHITECT  
**IAN DAVIDSON LANDSCAPE ARCHITECTURE**  
 3744 TENTH STREET, SUITE 200 STREET, RIVERSIDE, CA 92501  
 (951) 685-1283 (951) 685-4362 FAX

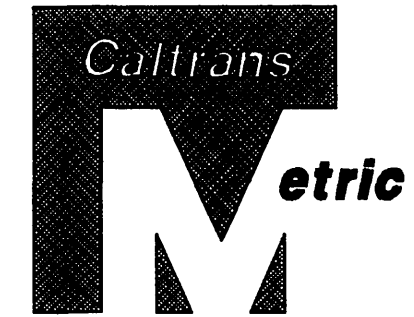

DIST	COUNTY	ROUTE	POST MILE PROJECT	TOTAL SHEET No	TOTAL SHEETS
08	Riv	91	-	3	14

LICENSED LANDSCAPE ARCHITECT

PLANS APPROVAL DATE

The State of California or its officers or agents shall not be responsible for the accuracy or completeness of electronic copies of this plan sheet.

Cal-Trans now has a web site! To get to the web site, go to: <http://tresp.dot.ca.gov>

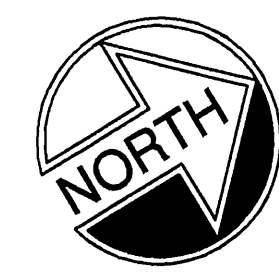
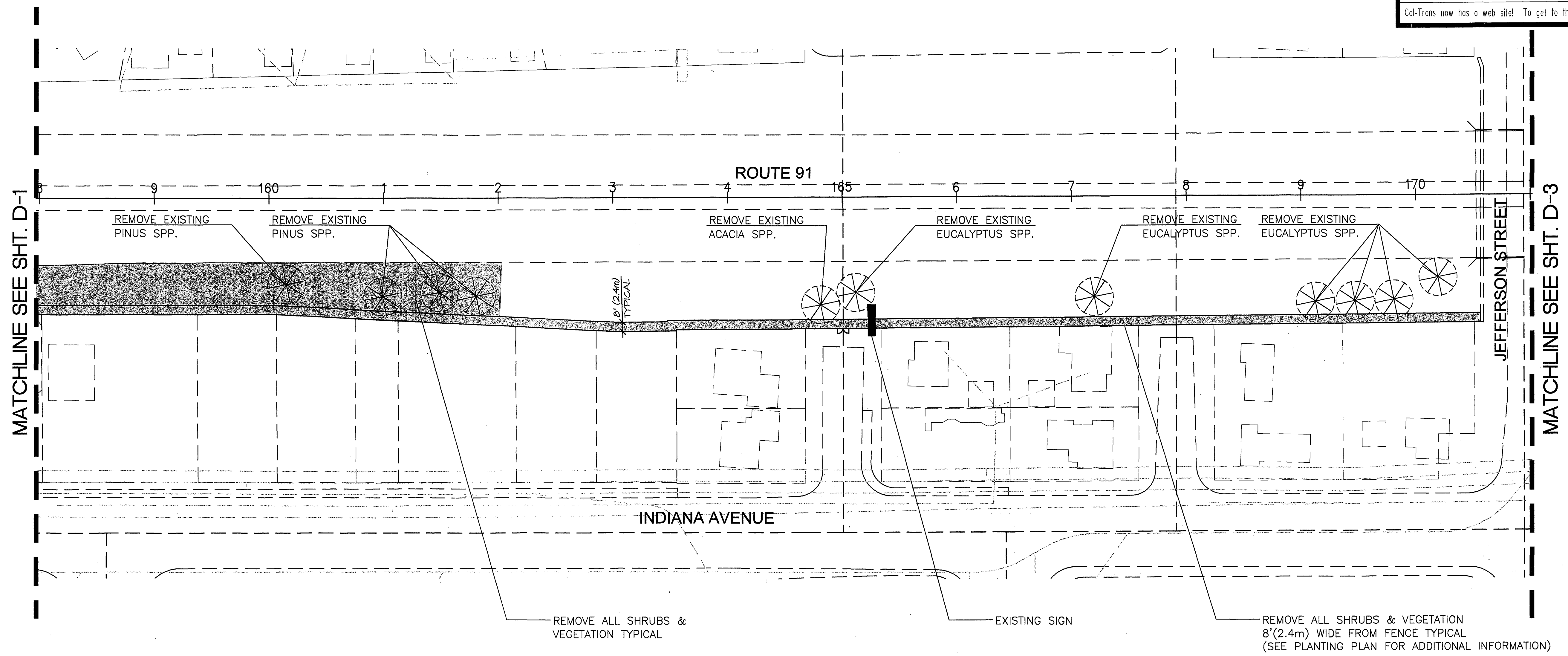

**DEMOLITION PLAN**  
 SCALE = 1:50/1:500  
**D-2**  
 PERMIT NUMBER 08-04-N-LF-1377

FOR REDUCED PLANS ORIGINAL SCALE IS IN MILLIMETERS

USERNAME:  
DGN FILE:

CU FED. EA NO.

EA STATE NO.

INDEXED 06-07-05 4ft

R-3842

DATE PLOTTED: Apr 06, 2005 - 11:44am  
 TIME PLOTTED: J:\2004\10704 - Route 91\Drawings\Landscaps\10704DM.dwg  
 USER: sseidman

STATE OF CALIFORNIA - DEPARTMENT OF TRANSPORTATION  
**Caltrans** LANDSCAPE ARCHITECTURE  
 PROJECT LANDSCAPE ARCHITECT  
**IAN DAVIDSON LANDSCAPE ARCHITECTURE**  
 3744 TENTH STREET, SUITE 200, STREET, RIVERSIDE, CA 92501  
 (951) 953-1285 (951) 953-4352 FAX

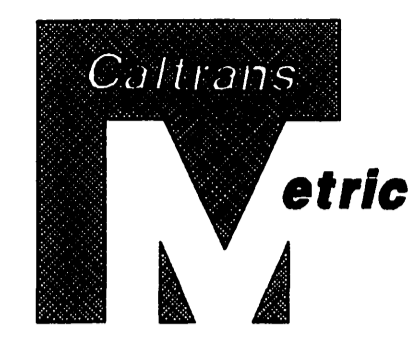

DIST	COUNTY	ROUTE	POST MILE PROJECT	TOTAL SHEET No	TOTAL SHEETS
08	Riv	91	-	4	14

LICENSED LANDSCAPE ARCHITECT

PLANS APPROVAL DATE

The State of California or its officers or agents shall not be responsible for the accuracy or completeness of electronic copies of this plan sheet.

Cal-Trans now has a web site! To get to the web site, go to: <http://tresp.dot.ca.gov>

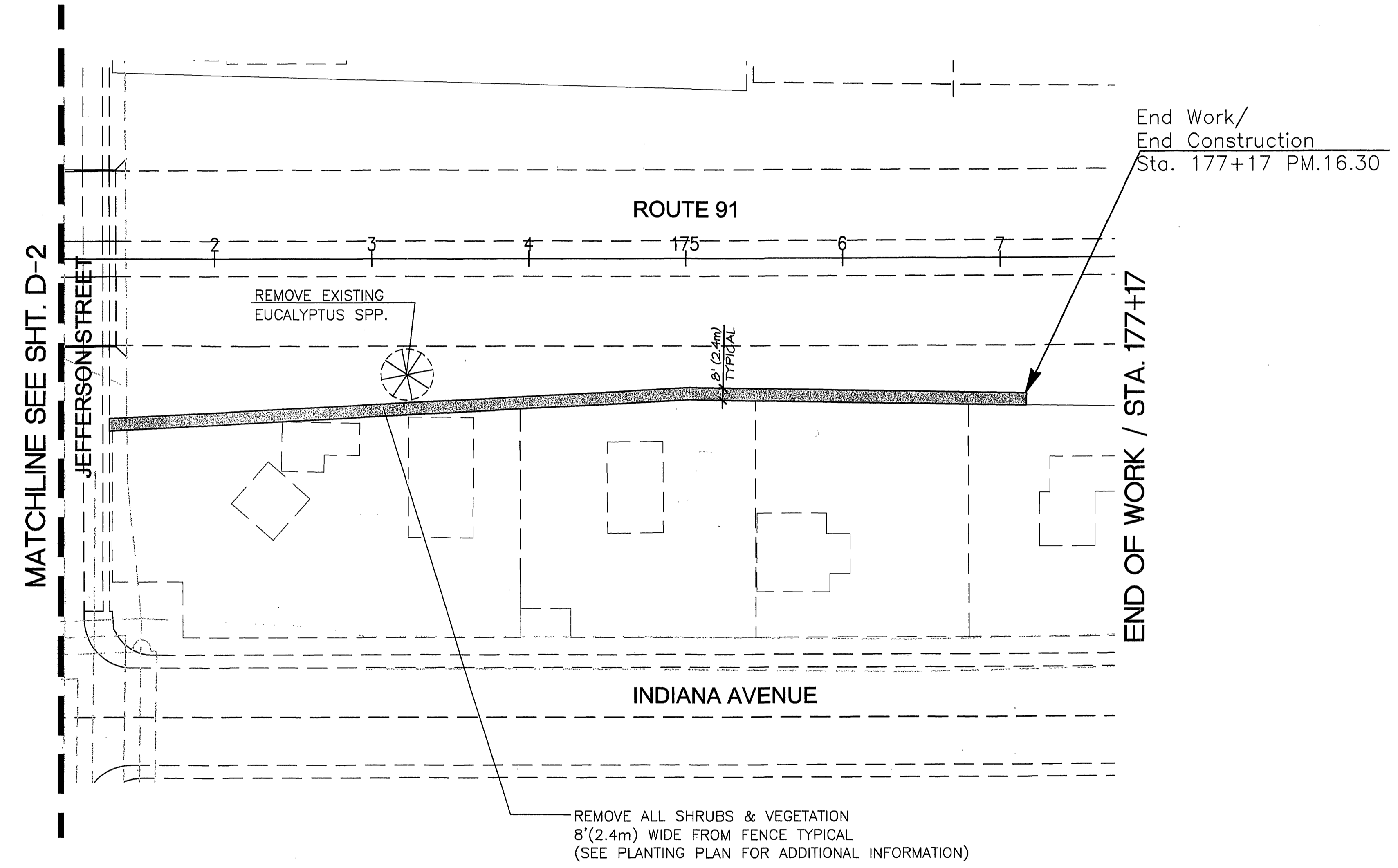

**DEMOLITION PLAN**  
 SCALE = 1:50/1:500  
**D-3**  
 PERMIT NUMBER 08-04-N-LF-1377

FOR REDUCED PLANS ORIGINAL SCALE IS IN MILLIMETERS

USERNAME:  
 DSN FILE:

CU FED. EA NO.  
 INDEXED 06-07-05 ftt

EA STATE NO.  
 R-3842

DATE PLOTTED: Apr 08, 2005 - 11:45am  
 TIME PLOTTED: J:\2004\10704 - Route 91 Drawings\landscape\10704DM.dwg  
 sseidman

STATE OF CALIFORNIA - DEPARTMENT OF TRANSPORTATION  
**Caltrans** LANDSCAPE ARCHITECTURE  
 PROJECT LANDSCAPE ARCHITECT  
**IAN DAVIDSON LANDSCAPE ARCHITECTURE**  
 3744 TENTH STREET, SUITE 200 STREET, RIVERSIDE, CA 92501  
 (951) 682-2288 (951) 682-2274 FAX

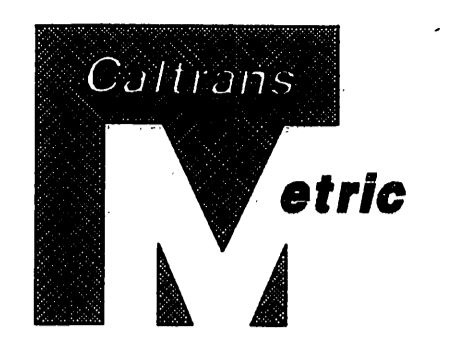

DIST	COUNTY	ROUTE	POST MILE PROJECT	TOTAL SHEET No	TOTAL SHEETS
08	Riv	91	-	5	14

LICENSED LANDSCAPE ARCHITECT

PLANS APPROVAL DATE

The State of California or its officers or agents shall not be responsible for the accuracy or completeness of electronic copies of this plan sheet.

Cal-Trans now has a web site! To get to the web site, go to: <http://fresc.dot.ca.gov>

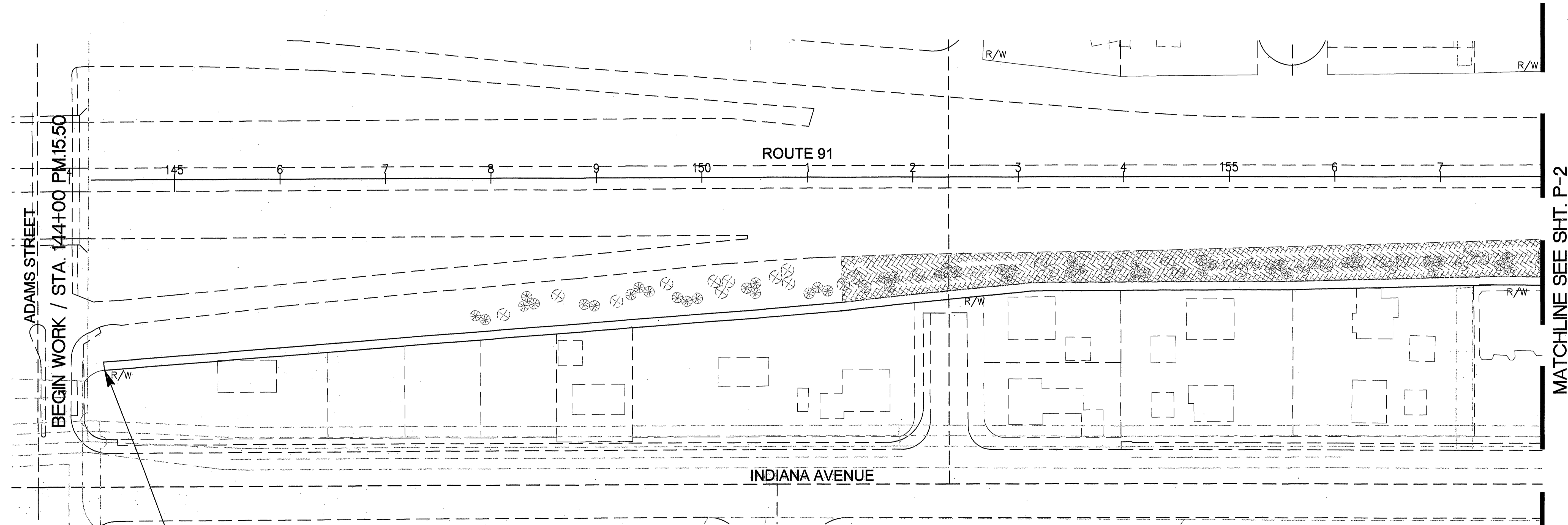
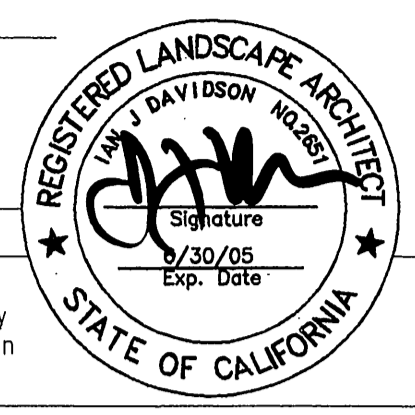

Begin Work/  
 Begin Construction  
 Sta. 144+32 PM.15.50

NOTE:  
 IRRIGATION SYSTEMS WITHIN THE STATE RIGHT-OF-WAY SHALL BE INSTALLED IN ACCORDANCE WITH THE PROVISIONS IN SECTION 20-5 'IRRIGATION SYSTEMS' OF THE CURRENT CALTRANS SPECIFICATIONS.

THE INSTALLATION OF IRRIGATION PIPE WITHIN STATES RIGHT-OF-WAY SHALL BE BY BORE AND JACK METHOD ONLY.

IRRIGATION SYSTEMS AS SHOWN ON THE PLANS, EXCEPT FOR SPRINKLER LOCATIONS, ARE DIAGRAMMATIC.

SPRINKLERS (TYPE C-2) WHEN LOCATED ON SLOPES, SHALL BE INSTALLED ON THE UPHILL SIDE OF THE TREE BASIN.

UNLABELED LATERAL PIPE (PR 200) DOWNSTREAM OF THE VALVE SHALL BE 20mm UNLESS OTHERWISE NOTED.

CONTROLLER SHALL BE SOLAR POWERED AS MANUF. BY: LEIT TECH. DIST. BY: DIG CORP. (800) 322-9146 MODEL: 4004. EXISTING VALVE SOLENOID TO BE CONVERTED TO A LEMA 1500 SERIES ACTUATOR.

NEW GROUNDCOVER AND SHRUB AREAS TO BE IRRIGATED BY EXISTING SYSTEM. ONLY NEW TREES ARE TO BE INCLUDED IN THE SCOPE OF WORK

MATCHLINE SEE SHT. P-2



USERNAME: DGN FILE:

CU FED. EA NO. EA STATE NO.

INDEXED 06-07-05 4H R-3842

DATE PLOTTED: Apr 06, 2005 - 12:37pm  
 TIME PLOTTED: J:\2004\10704 - Route 91\Drawings\Landscapes\10704IR.dwg  
 sseldron

STATE OF CALIFORNIA - DEPARTMENT OF TRANSPORTATION  
**Caltrans** LANDSCAPE ARCHITECTURE  
 PROJECT LANDSCAPE ARCHITECT  
**IAN DAVIDSON LANDSCAPE ARCHITECTURE**  
 3744 TENTH STREET, SUITE 200 STREET, RIVERSIDE, CA 92504  
 (951) 685-1283 (951) 685-4532 FAX

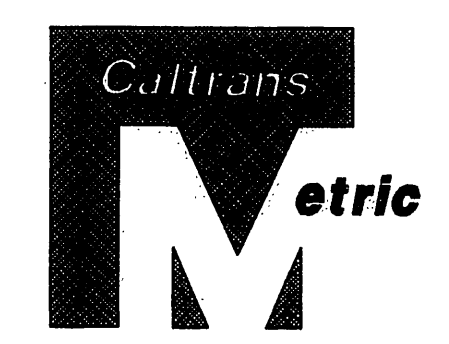

DIST	COUNTY	ROUTE	POST MILE PROJECT	TOTAL SHEET No	TOTAL SHEETS
08	Riv	91	-	6	14

LICENSED LANDSCAPE ARCHITECT

PLANS APPROVAL DATE

The State of California or its officers or agents shall not be responsible for the accuracy or completeness of electronic copies of this plan sheet.

Cal-Trans now has a web site! To get to the web site, go to: <http://tresp.dot.ca.gov>

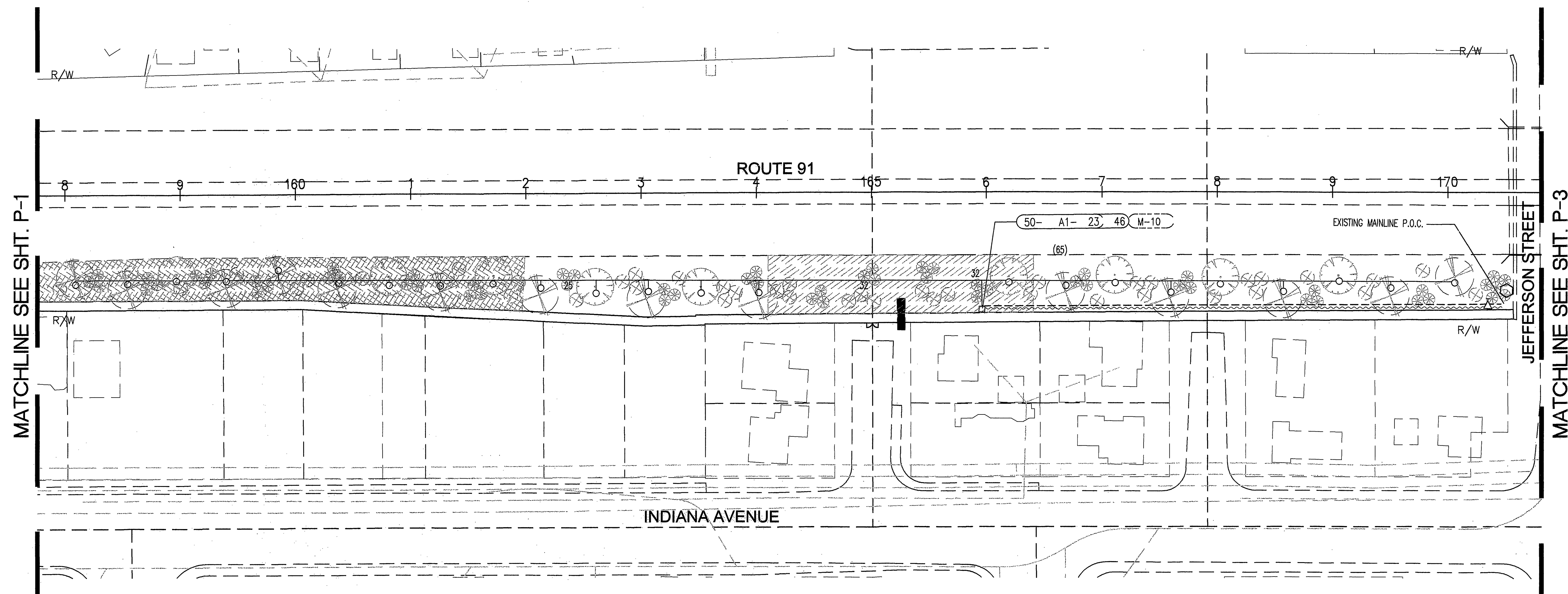
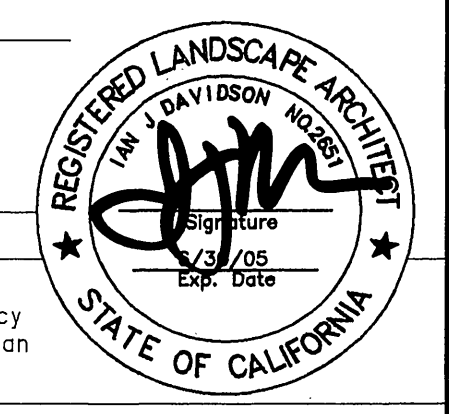

NEW GROUNDCOVER AND SHRUB AREAS TO BE IRRIGATED BY EXISTING SYSTEM. ONLY NEW TREES ARE TO BE INCLUDED IN THE SCOPE OF WORK



**IRRIGATION PLAN**  
 SCALE = 1:50/1:500  
 I-2  
 PERMIT NUMBER 08-04-N-LF-1377

FOR REDUCED PLANS ORIGINAL SCALE IS IN MILLIMETERS

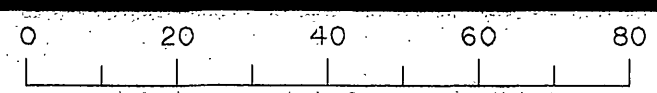

USERNAME: DGN FILE:

CU FED. EA NO.

EA STATE NO.

INDEXED 06-07-05 44

R-3842

DATE PLOTTED: Apr 06, 2005 - 12:37pm  
 TIME PLOTTED: 4:2004\10704 - Route 91\Drawings\Landscapes\10704R.dwg  
 USER: sseidman

x  
x  
x  
x  
x

STATE OF CALIFORNIA - DEPARTMENT OF TRANSPORTATION	PROJECT LANDSCAPE ARCHITECT	CALCULATED/DESIGNED BY	DATE	REVISOR	DATE
<b>Caltrans</b> LANDSCAPE ARCHITECTURE	IAN DAVIDSON LANDSCAPE ARCHITECTURE 3704 TENTH STREET, SUITE 100, SAN DIEGO, CA 92101 (619) 451-1233 (619) 451-4273 FAX	CHECKED BY		DATE	REVISOR

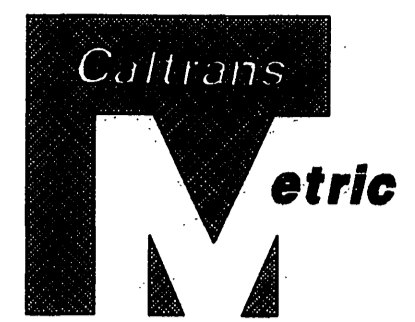
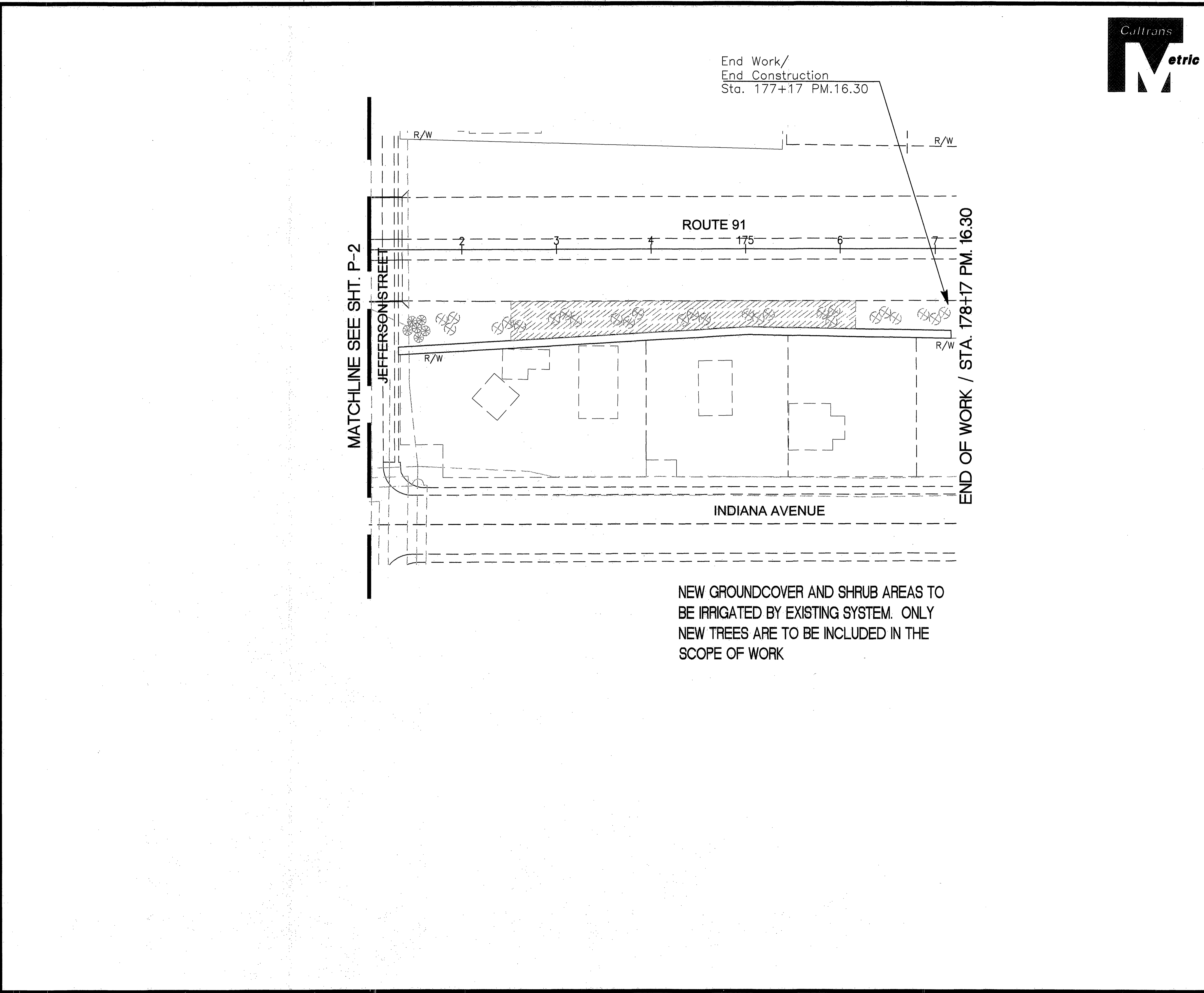

DIST	COUNTY	ROUTE	POST MILE PROJECT	TOTAL SHEET No	TOTAL SHEETS
08	Riv	91	-	7	14

LICENSED LANDSCAPE ARCHITECT

PLANS APPROVAL DATE

The State of California or its officers or agents shall not be responsible for the accuracy or completeness of electronic copies of this plan sheet.

Col-Trans now has a web site! To get to the web site, go to: <http://tresp.dot.ca.gov>

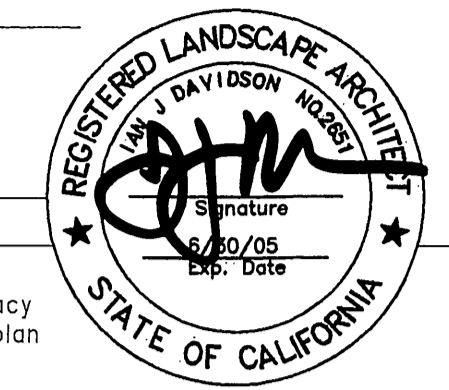

FOR REDUCED PLANS ORIGINAL SCALE IS IN MILLIMETERS

0 20 40 60 80

USERNAME: DGN FILE:

CU FED. EA NO. EA STATE NO.

INDEXED 06-07-05 LFH R-3842

DATE PLOTTED: Apr 06, 2005 - 12:37pm  
TIME PLOTTED: j:\2004\10704 - Route 91\Drawings\Landscaps\10704R.dwg  
LAST REVISION: sseidman

x  
x  
x  
x  
x

STATE OF CALIFORNIA - DEPARTMENT OF TRANSPORTATION

**Caltrans** LANDSCAPE ARCHITECTURE

PROJECT LANDSCAPE ARCHITECT  
IAN DAVIDSON LANDSCAPE ARCHITECTURE  
3744 TENTH STREET, SUITE 200 STREET, RIVERSIDE, CA 92501  
(951) 685-1293 (951) 685-1582 FAX

DESIGNED BY	DATE	REVISOR	DATE
CHECKED BY			

**ABBREVIATIONS**

- EA : Each            mm : Millimeter  
 DIP : Ductile Iron Pipe    PR : Pressure Rated  
 GSP : Galvanized Steel Pipe    MPa : Megapascals  
 m : Meter

NOTE:  
 IRRIGATION SYSTEMS WITHIN THE STATE RIGHT-OF-WAY SHALL BE  
 INSTALLED IN ACCORDANCE WITH THE PROVISIONS IN SECTION 20-5  
 'IRRIGATION SYSTEMS' OF THE CURRENT CALTRANS SPECIFICATIONS.

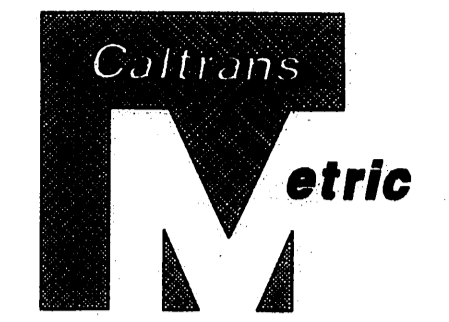

DIST	COUNTY	ROUTE	POST MILE PROJECT	TOTAL SHEET No	TOTAL SHEETS
08	Riv	91	-	8	14

LICENSED LANDSCAPE ARCHITECT

PLANS APPROVAL DATE: 8/30/05

Exp. Date: 8/30/05

The State of California or its officers or agents shall not be responsible for the accuracy or completeness of electronic copies of this plan sheet.

Cal-Trans now has a web site! To get to the web site, go to: <http://fresc.do1.ca.gov>

THE INSTALLATION OF IRRIGATION PIPE WITHIN STATES  
 RIGHT-OF-WAY SHALL BE BY BORE AND JACK METHOD ONLY.  
 SUBTOTALS PER VALVE ON LATERAL SUPPLY SIDE OF CONTROL VALVE  
 VALVE OR ASSEMBLY NUMBER

DESCRIPTION			UNIT	A-1																																				SUBTOTALS	UNIT	DESCRIPTION		
PLASTIC PIPE SUPPLY LINE	PR 200	20 mm / 3/4 in	m / ft	247 / 810																																				247 / 810	m / ft	20 mm / 3/4 in	PR 315	PLASTIC PIPE SUPPLY LINE
		25 mm / 1 in	m / ft	58 / 190																																				58 / 190	m / ft	25 mm / 1 in		
		32 mm / 1 1/4 in	m / ft	63 / 207																																				63 / 207	m / ft	32 mm / 1 1/4 in		
		40 mm / 1 1/2 in	m / ft																																						m / ft	40 mm / 1 1/2 in		
PLASTIC PIPE SUPPLY LINE	PR 315 ISCH 40	50 mm / 2 in	m / ft																																						m / ft	50 mm / 2 in	PR 315	PLASTIC PIPE SUPPLY LINE
		65 mm / 2 1/2 in	m / ft																																						m / ft	65 mm / 2 1/2 in		
GSP																																											GSP	
SPRINKLER TYPE	A-5	EA																																				EA	A-5	SPRINKLER TYPE				
	A-6	EA																																				EA	A-6					
	A-7	EA																																				EA	A-7					
	A-8	EA																																				EA	A-8					
	B-1	EA																																				EA	B-1					
	B-2	EA																																				EA	B-2					
	B-4	EA																																				EA	B-4					
	C-2	EA	46																																				46		EA	C-2		

DESCRIPTION			UNIT																																				SUBTOTALS	UNIT	DESCRIPTION		
PLASTIC PIPE SUPPLY LINE	PR 315	20 mm	m																																					m	20 mm	PR 315	PLASTIC PIPE SUPPLY LINE
		25 mm	m																																					m	25 mm		
		32 mm	m																																					m	32 mm		
		40 mm	m																																					m	40 mm		
PLASTIC PIPE SUPPLY LINE	PR 315 ISCH 40	50 mm	m																																					m	50 mm	PR 315 ISCH 40	PLASTIC PIPE SUPPLY LINE
		65 mm	m																																					m	65 mm		
GSP																																										GSP	
SPRINKLER TYPE	A-5	EA																																					EA	A-5	SPRINKLER TYPE		
	A-6	EA																																					EA	A-6			
	A-7	EA																																					EA	A-7			
	A-8	EA																																					EA	A-8			
	B-1	EA																																					EA	B-1			
	B-2	EA																																					EA	B-2			
	C-2	EA																																					EA	C-2			

**IRRIGATION QUANTITIES**  
 IO-1

PERMIT NUMBER 08-04-N-LF-1377

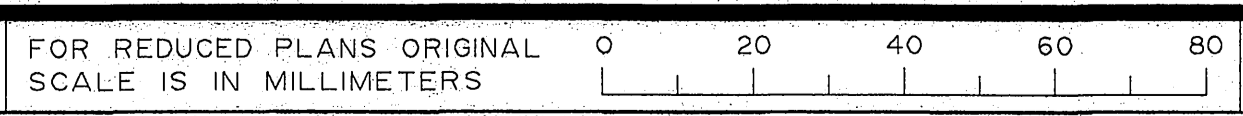

CU FED. EA NO.      EA STATE NO.

INDEXED 06-07-05 44 R= 3842

DATE PLOTTED: Apr 06, 2005 - 12:36pm    user: aseldman  
 TIME PLOTTED: J:\2004\10704 - Route 91\Drawings\Landscapes\10704IR.dwg



STATE OF CALIFORNIA - DEPARTMENT OF TRANSPORTATION  
**Caltrans** LANDSCAPE ARCHITECTURE  
 PROJECT LANDSCAPE ARCHITECT  
**IAN DAVIDSON LANDSCAPE ARCHITECTURE**  
 3744 TENTH STREET, SUITE 200 STREET, RIVERSIDE, CA 92501  
 (951) 885-1283 (951) 885-4382 FAX

**SUBTOTALS PER PLAN SHEET ON MAIN SUPPLY SIDE OF CONTROL VALVE**

DESCRIPTION	UNIT	SHEET NUMBER										SUBTOTALS	
		1-2											
BPA	50 mm EA												
	ENCLOSURE EA												
BOOSTER PUMP													
IRRIGATION CONTROLLER	24 STATION												
	4 STATION SOLAR	1											1
	SINGLE	EA											
	DOUBLE	EA											
	40 mm EA												
VALVES AND ASSEMBLIES													
	32 mm / 1 1/4 in EA	1											1
	40 mm EA												
	32 mm / 1 1/4 in EA	1											1
	20 mm EA												
	50 mm EA												
	40 mm EA												
CONDUIT	250 mm EA												
	250 mm												
	75 mm / 3 in	150											150
PLASTIC PIPE SUPPLY LINE													
	20 mm m												
	25 mm m												
	32 mm m												
	40 mm m												
	65 mm m												
	75 mm m												
	50 mm m												

**TOTAL QUANTITIES**

TOTALS	UNIT	DESCRIPTION
		BPA
		ENCLOSURE
		BOOSTER PUMP
		STATION
1	EA	4 STATION
		STATION
		SINGLE
		DOUBLE
		VALVES AND ASSEMBLIES
1	EA	32 mm / 1 1/4 in
1	EA	32 mm / 1 1/4 in
		CONDUIT
150 / 492	m / ft	75 mm / 3 in
		PLASTIC PIPE SUPPLY LINE
247 / 810	m / ft	20 mm / 3/4 in
58 / 190	m / ft	25 mm / 1 in
63 / 207	m / ft	32 mm / 1 1/4 in
		DIP -GSP
46	EA	C-2
		SPRINKLER TYPE

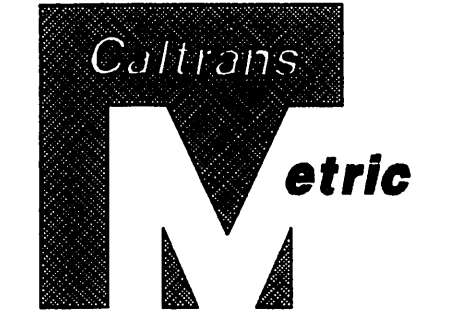

DIST	COUNTY	ROUTE	POST MILE PROJECT	TOTAL SHEET No	TOTAL SHEETS
08	Riv	91	-	9	14

LICENSED LANDSCAPE ARCHITECT

PLANS APPROVAL DATE

The State of California or its officers or agents shall not be responsible for the accuracy or completeness of electronic copies of this plan sheet.

Cal-Trans now has a web site! To get to the web site, go to: <http://trecs.dot.ca.gov>



- LEGEND**
- ① AMBIENT LIGHT POWERED IRRIGATION CONTROLLER, SERIES X, XR, AND XRC. MODEL X 10 TO 28 STATIONS. MODEL XR (WITH OPTIONAL RADIO) 4 TO 28 STATIONS. MODEL XRC WITH RADIO REMOTE 4 TO 28 STATIONS.
  - ② TERMINAL STRIP.
  - ③ 12 OR 14 GAUGE WIRE.
  - ④ PROGRAMMING KEY. LEIT KEY
  - ⑤ 35" STEEL MOUNTING COLUMN. MODEL NUMBER: MCOLXS (SHORT) OR 50" STEEL MOUNTING COLUMN. MODEL NUMBER: MCOLXL (LONG) FINISH GRADE.
  - ⑥ 6-1/2" OF BACKFILL SOIL.
  - ⑦ POURED CONCRETE BASE- 1-1/2 CU. FT. INSTALL PER MANUFACTURER'S INSTALLATION GUIDE.
  - ⑧ DIRECT BURIAL CONTROL WIRES TO CONTROL VALVES.

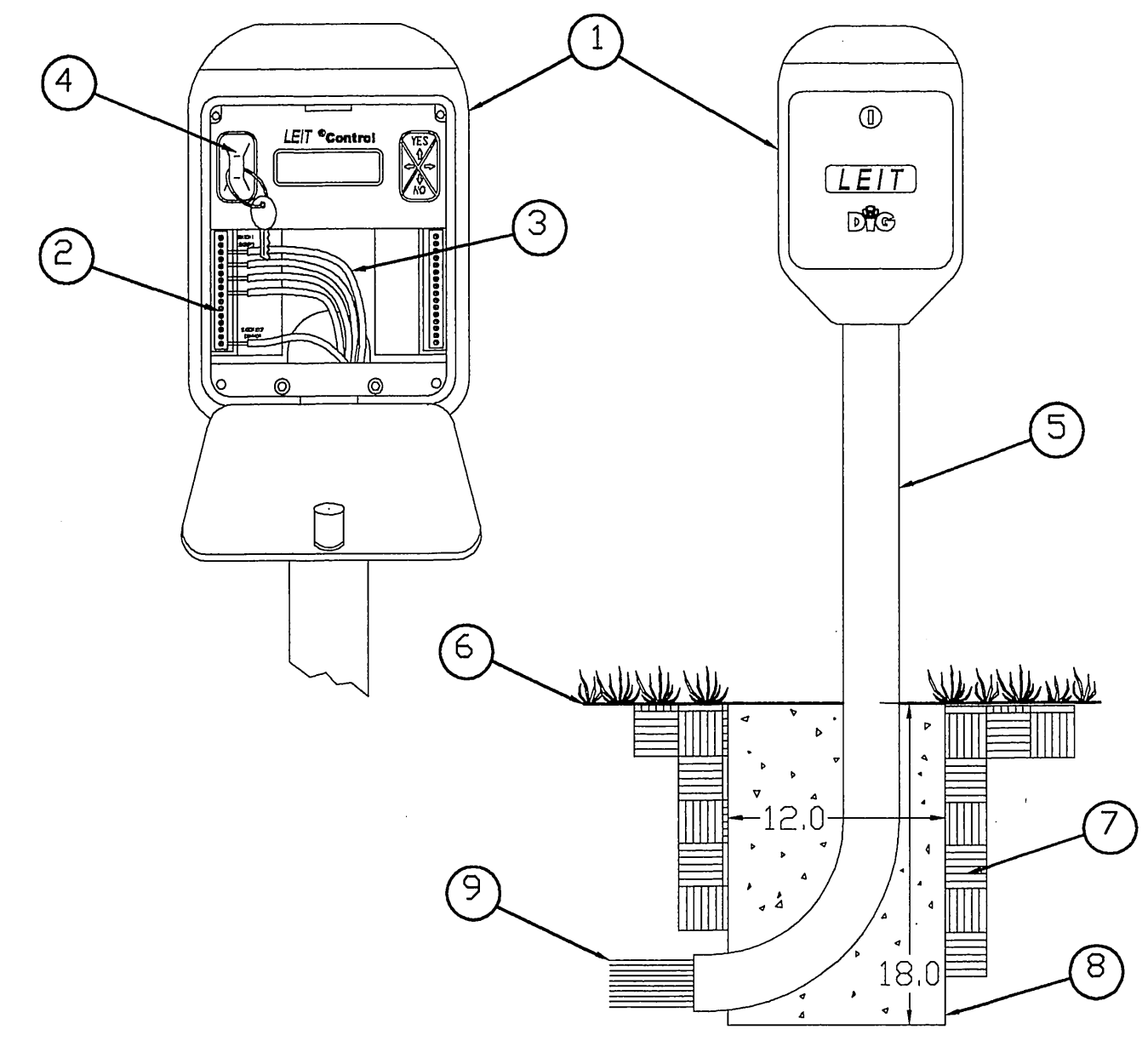

① LIGHT ENERGIZED IRRIGATION CONTROLLER  
 LEIT CONTROL X , XR AND XRC

- ABBREVIATIONS**
- |                                    |                             |                                      |
|------------------------------------|-----------------------------|--------------------------------------|
| BRA — backflow preventer assembly  | FCV — flow control valve    | PR — pressure rated                  |
| BV — ball valve                    | FS — flow sensor            | PRV — pressure reducing valve        |
| CV — check valve                   | FV — flush valve            | PRLV — pressure relief valve         |
| CEC — controller enclosure cabinet | GSP — galvanized steel pipe | QCV — quick coupling valve           |
| CSP — corrugated steel pipe        | GV — gate valve             | RCV — remote control valve           |
| DIP — ductile iron pipe            | MCV — manual control valve  | RCVM — remote control valve (master) |
| EA — each                          | m — meter                   | VAU — valve assembly unit            |
| FAU — filter assembly unit         | mm — millimeter             | WSP — welded steel pipe              |
|                                    |                             | WS — wye strainer                    |

NOTE:  
 IRRIGATION SYSTEMS WITHIN THE STATE RIGHT-OF-WAY SHALL BE INSTALLED IN ACCORDANCE WITH THE PROVISIONS IN SECTION 20-5 'IRRIGATION SYSTEMS' OF THE CURRENT CALTRANS SPECIFICATIONS.

THE INSTALLATION OF IRRIGATION PIPE WITHIN STATES RIGHT-OF-WAY SHALL BE BY BORE AND JACK METHOD ONLY.

**IRRIGATION QUANTITIES**  
 IO-2  
 PERMIT NUMBER 08-04-N-LF-1377

FOR REDUCED PLANS ORIGINAL SCALE IS IN MILLIMETERS

USERNAME: DGN FILE:

CU FED. EA NO. EA STATE NO.

INDEXED 06-07-05 Lfh R-3842

DATE PLOTTED: Apr 08, 2005 - 11:45am USERNAME: sselimon  
 TIME PLOTTED: J:\2004\10704 - Route 91\Drawings\Landscape\10704R.dwg LAST REVISION

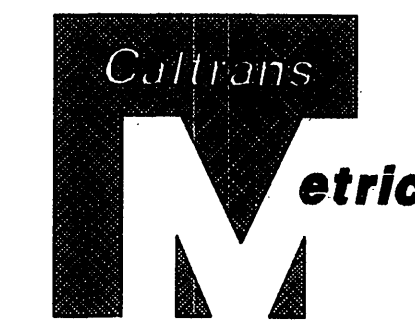

DIST	COUNTY	ROUTE	POST MILE PROJECT	TOTAL SHEET No	TOTAL SHEETS
08	Riv	91	-	10	14

LICENSED LANDSCAPE ARCHITECT

PLANS APPROVAL DATE

The State of California or its officers or agents shall not be responsible for the accuracy or completeness of electronic copies of this plan sheet.

Col-Trons now has a web site! To get to the web site, go to: <http://tresp.dof.ca.gov>

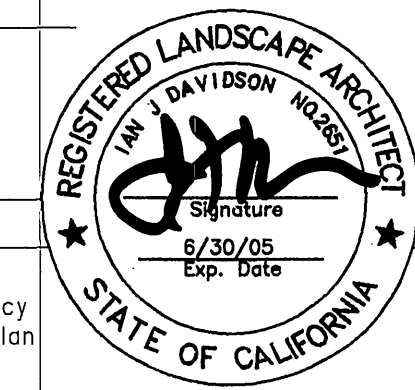

### SPRINKLER SCHEDULE

SYMBOL	TYPE	DESCRIPTION	SPRAY PATTERN	OPERATING PRESSURE (KILOPASCAL)	PRESSURE COMPENSATING	PLUS/MINUS 5%				MATERIAL	NOZZLE SIZE (MILLIMETERS)	INLET CONNECTION (INPT MILLIMETERS)	POSITIVE-LOCKING ADJ ARC STOP	BACKSLASH PREVENTER	DIFFUSER PIN	DISTANCE CONTROL FLAP	ADJ DISCHARGE	RISER				REMARKS			
						DISCHARGE		RADIUS (METERS)	WIDTH/LENGTH (MILLIMETERS)									MATERIAL		SWING JOINT (TYPE)	RISER SUPPORT		SPRINKLER PROTECTOR (TYPE)		
						LITERS PER SECOND	LITERS PER MINUTE											PLASTIC	GALVANIZED					SIZE (IPS) (MILLIMETERS)	HEIGHT (MILLIMETERS)
O	C-2	FLOOD BUBBLER	-	206	X	.03	1.89	-	-	PL	-	13	-	-	-	-	V	X	-	13	-	-	-	-	EACH SYMBOL REPRESENTS TWO BUBBLERS PER TREE, PLACE BUBBLERS AT EDGE OF ROOTBALL ON OPPOSITE SIDES OF THE TREE. (TYPICAL)

X : DENOTES REQUIREMENT

APPLICABLE WHEN CIRCLED:

- ARC STOP SHALL BE FITTED WITH A NUT AND BOLT.
- VINYL-COATED CAST IRON HOUSING.
- SWING JOINTS REQUIRED ADJACENT TO SHOULDERS, CURBS, SIDEWALKS AND DIKES.
- UNLESS OTHERWISE SHOWN ON PLANS.
- SEE SPECIAL PROVISIONS.

#### ABBREVIATIONS

- |                              |                               |
|------------------------------|-------------------------------|
| F : FULL CIRCLE              | L : LENGTH OF COVERAGE        |
| P : PART CIRCLE              | FT : FEET/FOOT                |
| F/P : FULL/PART CIRCLE       | IN : INCH(ES)                 |
| Q : QUARTER CIRCLE           | GPM : GALLONS PER MINUTE      |
| T : THIRD CIRCLE             | GPH : GALLONS PER HOUR        |
| H : HALF CIRCLE              | ADJ : ADJUSTABLE              |
| TT : TWO THIRD CIRCLE        | PL : PLASTIC                  |
| TQ : THREE QUARTER CIRCLE    | B/B : BRASS/BRONZE            |
| CST : CENTER STRIP           | B/PL : BRASS/PLASTIC          |
| SST : SIDE STRIP             | B/B/PL : BRASS/BRONZE/PLASTIC |
| EST : END STRIP              | NPT : NATIONAL PIPE THREAD    |
| PSI : POUNDS PER SQUARE INCH | IPS : IRON PIPE SIZE          |
| W : WIDTH OF COVERAGE        | FG : FINISHED GRADE           |

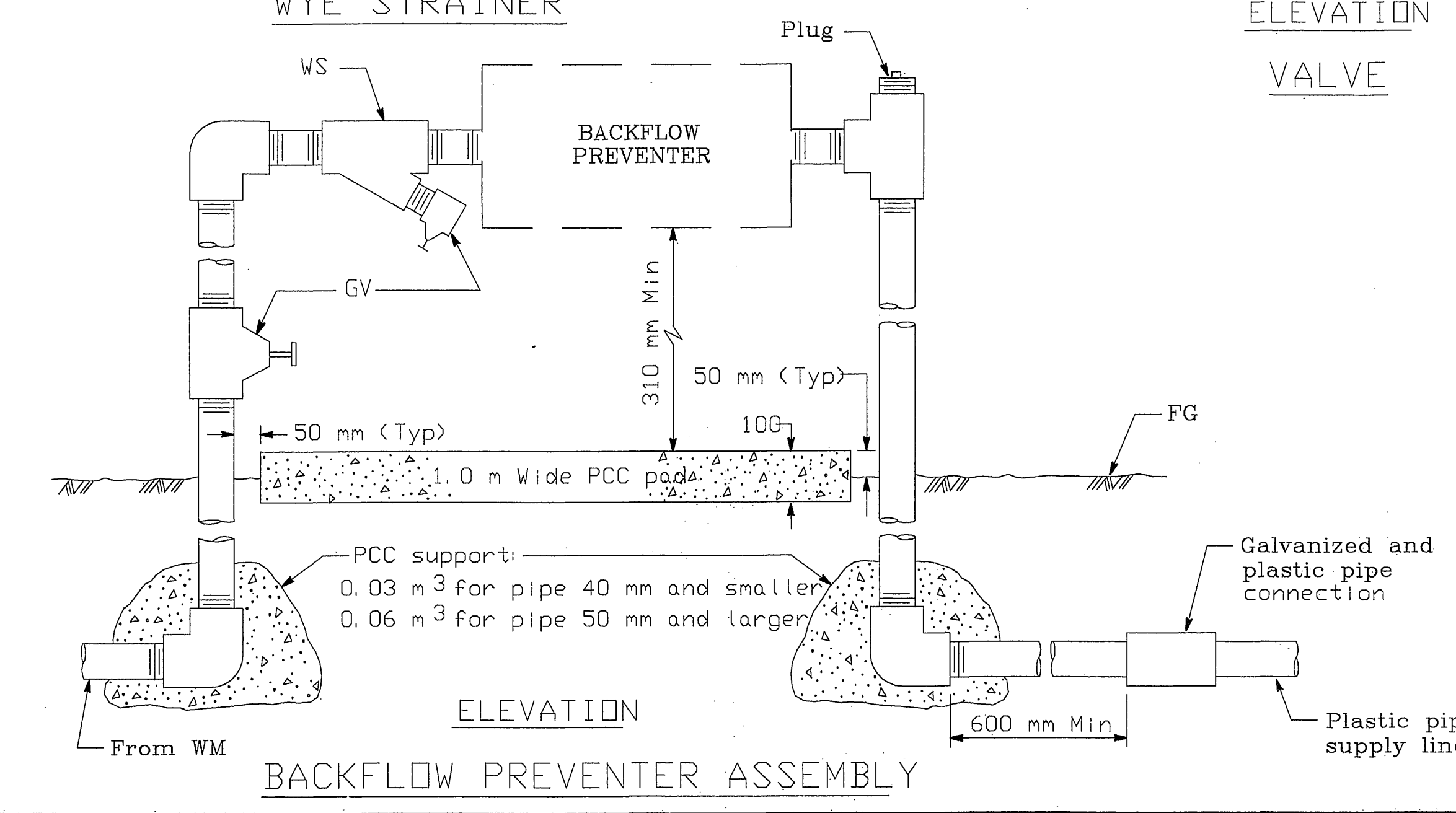
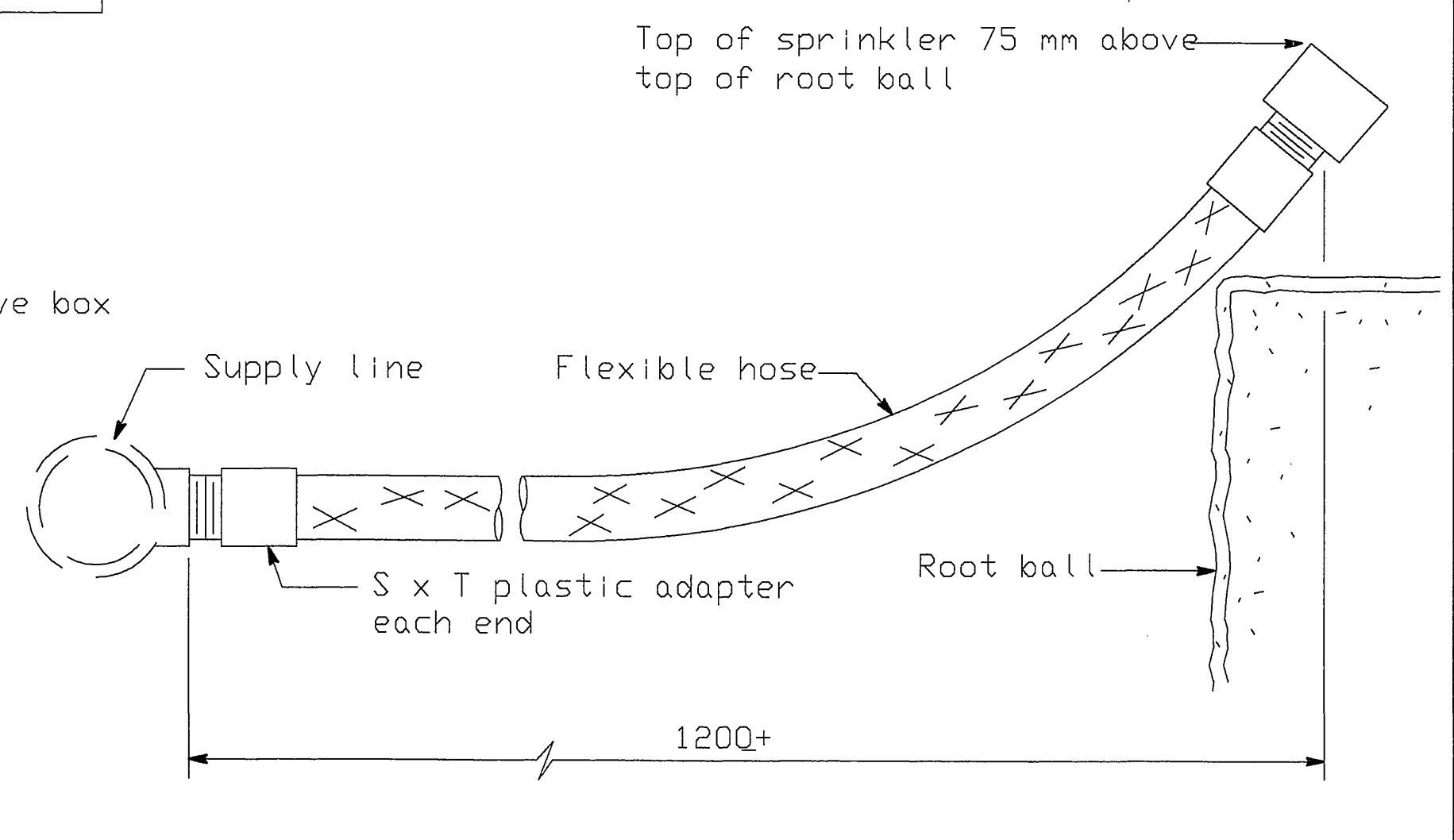
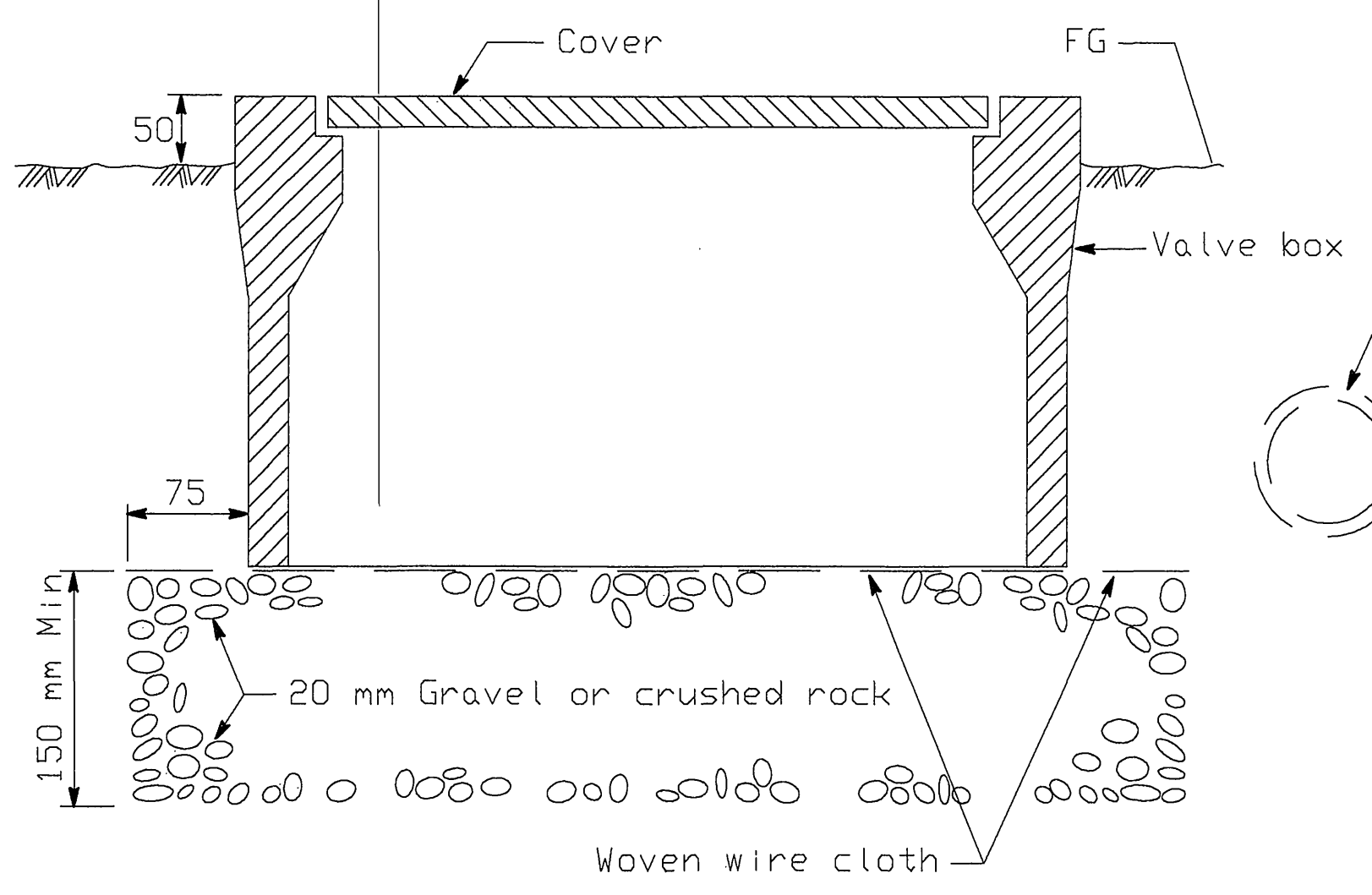
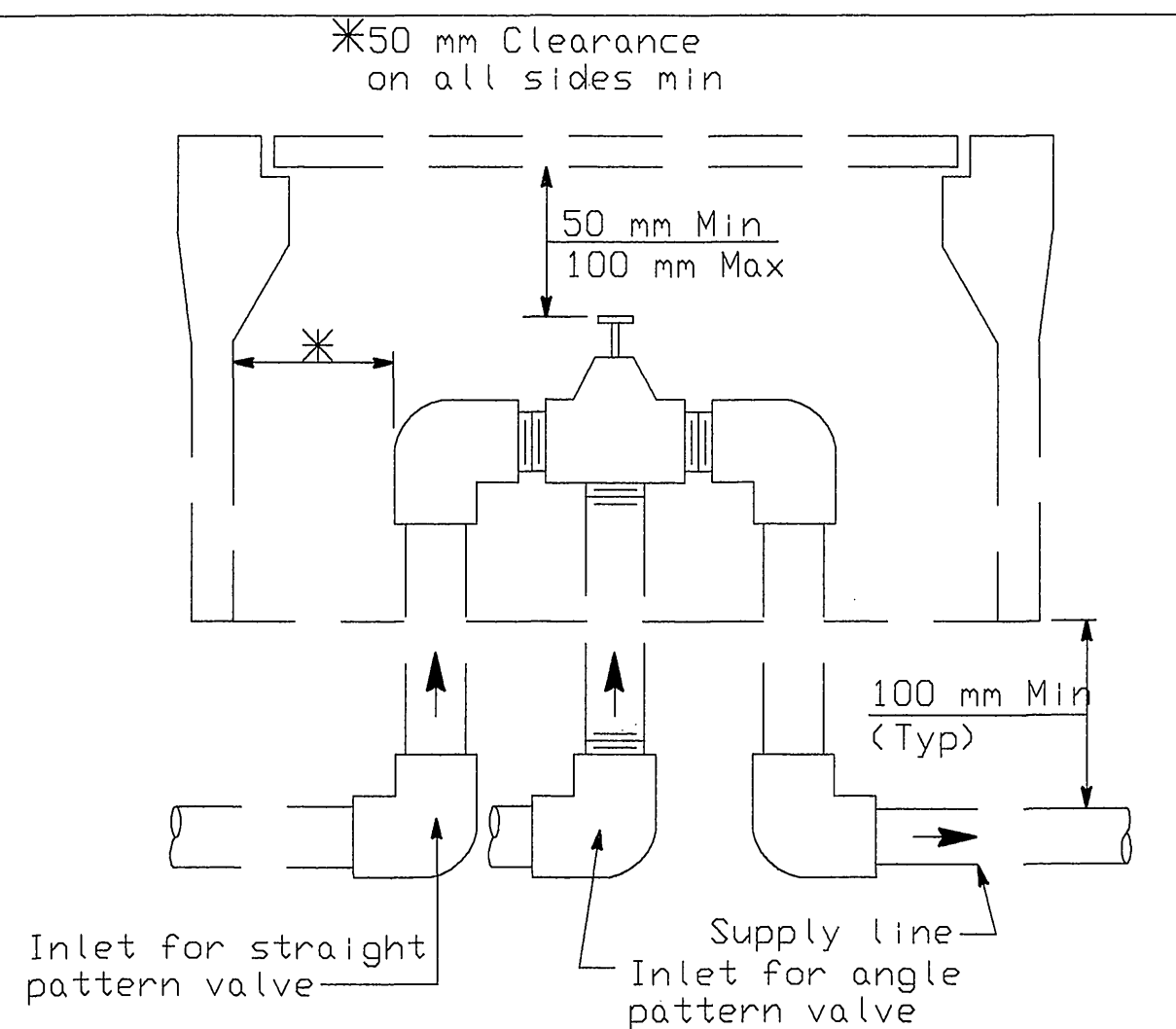
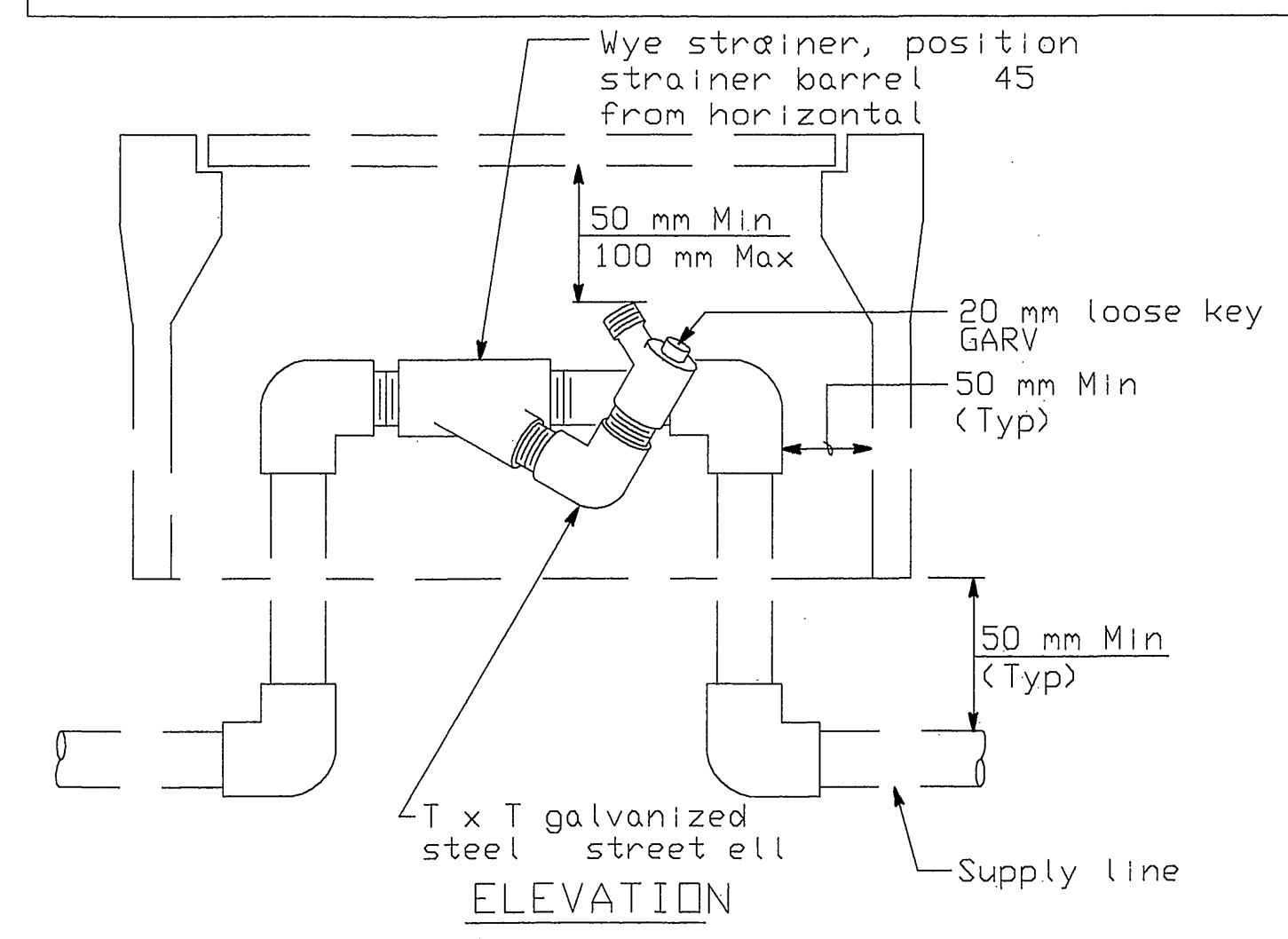

Identification label:  
For abbreviations see Standard Plans H1 and H2.  
For controller and station number see project plans.

Reclaimed water warning label when required

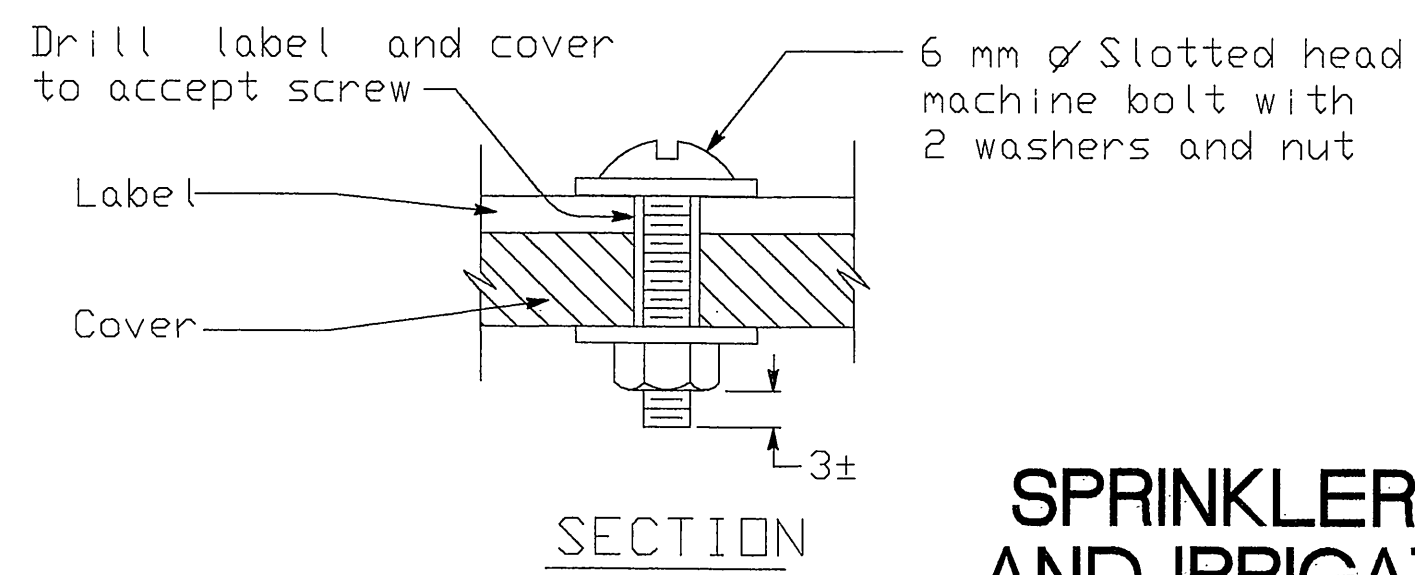
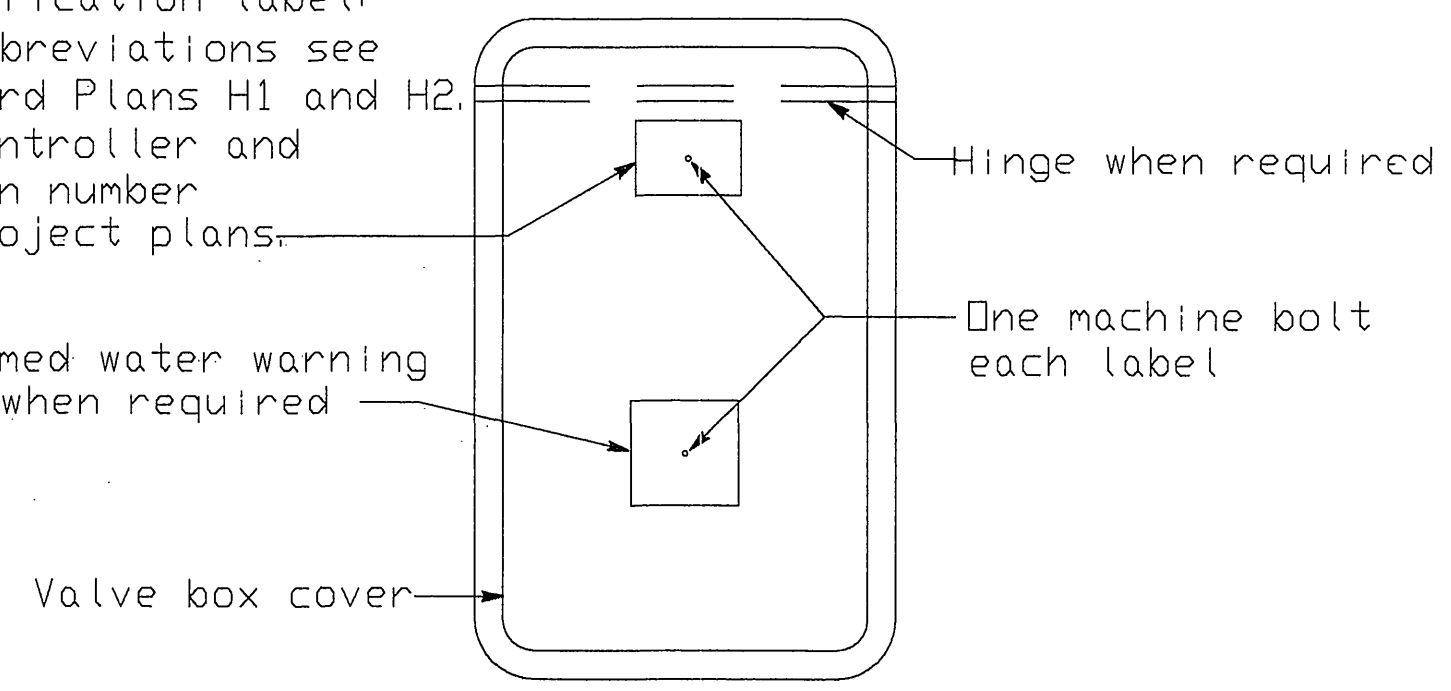

### SPRINKLER SCHEDULE AND IRRIGATION DETAILS

SD-1

PERMIT NUMBER 08-04-N-LF-1377

FOR REDUCED PLANS ORIGINAL SCALE IS IN MILLIMETERS

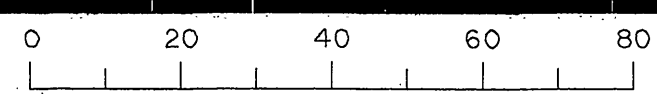

USERNAME: DGN FILE:

CU FED. EA NO.

EA STATE NO.

INDEXED 06-07-05 LFL

R-3842

STATE OF CALIFORNIA - DEPARTMENT OF TRANSPORTATION

PROJECT LANDSCAPE ARCHITECT

IAN DAVIDSON LANDSCAPE ARCHITECTURE

3044 Tenth Street, Suite 100, San Francisco, CA 94103

LANDSCAPE ARCHITECTURE

DATE PLOTTED: Apr 06, 2005 12:38pm

TIME PLOTTED: J:\2004\10704 - Route 91\Drawings\Landscapes\10704R.dwg

LAST REVISION: sseidman

STATE OF CALIFORNIA - DEPARTMENT OF TRANSPORTATION  
**Caltrans** LANDSCAPE ARCHITECTURE  
 PROJECT LANDSCAPE ARCHITECT  
**IAN DAVIDSON LANDSCAPE ARCHITECTURE**  
 2744 TENTH STREET, SUITE 200 STREET, RIVERSIDE, CA 92501  
 (951) 685-1283 (951) 685-4352 FAX

DIST	COUNTY	ROUTE	POST MILE	TOTAL SHEET	TOTAL SHEETS
08	Riv	91	-	11	14

LICENSED LANDSCAPE ARCHITECT

PLANS APPROVAL DATE

The State of California or its officers or agents shall not be responsible for the accuracy or completeness of electronic copies of this plan sheet.

Cal-Trans now has a web site! To get to the web site, go to: <http://tresp.dot.ca.gov>

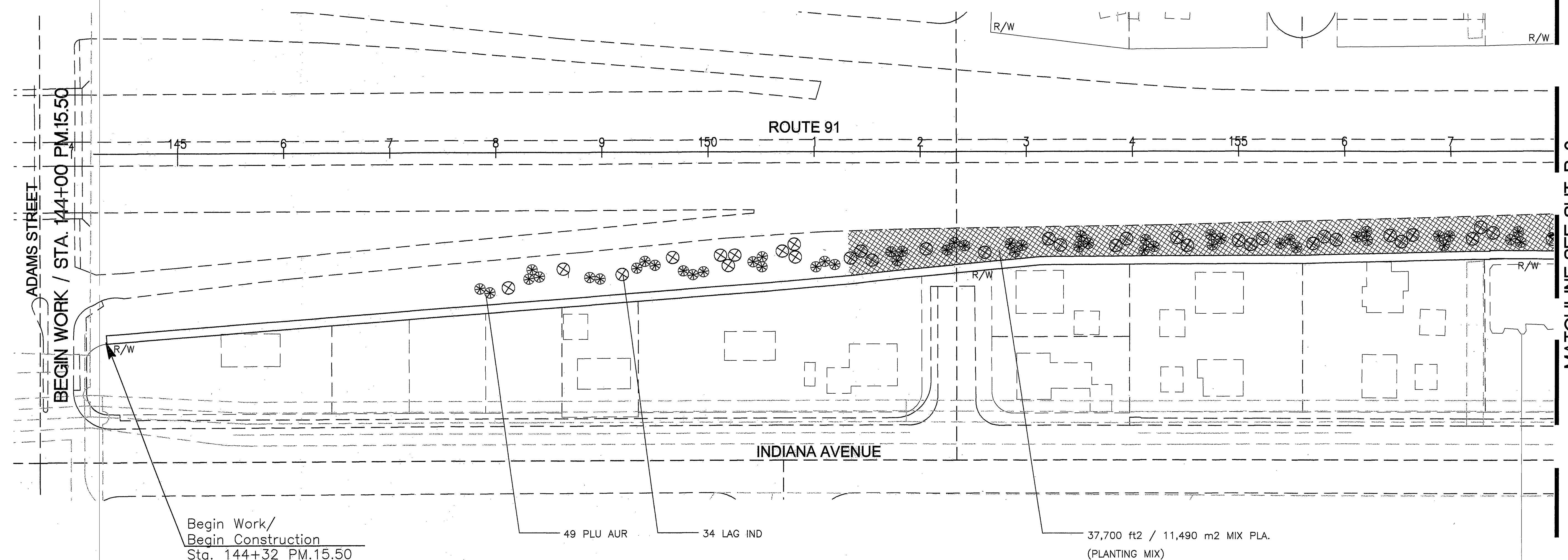
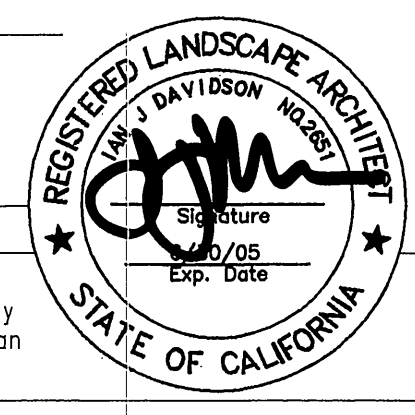
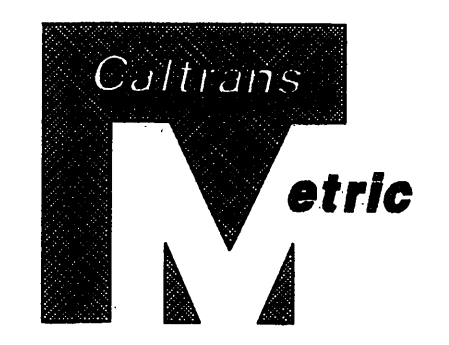

- GENERAL NOTES:
- 1). ALL WORK PERFORMED IN CONNECTION WITH HIGHWAY PLANTING WITHIN THE STATE RIGHT-OF-WAY SHALL CONFORM TO THE PROVISIONS IN SECTION 20-4 'HIGHWAY PLANTING' OF THE CURRENT CALTRANS SPECIFICATIONS.
  - 2). CONTRACTOR SHALL INSTALL GROUNDCOVER TO ALL AREAS WHICH HAVE BARE SPOTS AND /OR AREAS IN DECLINE. THESE AREAS MAY NOT BE SHOWN ON THE PLANS, THUS REQUIRING FIELD VERIFICATION. ALL GROUNDCOVER SHALL MATCH EXISTING. CONTRACTOR SHALL ESTIMATE 9,138 S.F.(849 Sq.m) FOR BID PURPOSES.
  - 3). ALL EXISTING IRRIGATION SHALL BE PROTECTED IN PLACE.

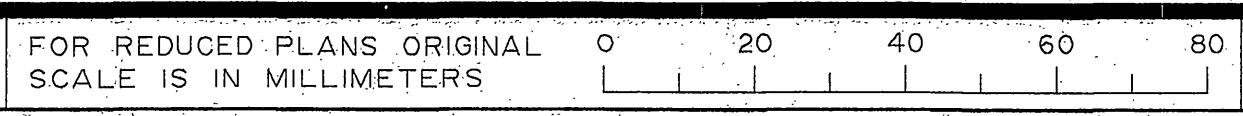

USERNAME: DGN FILE:

CU FED. EA NO. EA STATE NO.

INDEXED 06-07-05 Lfk R-3842

DATE PLOTTED: Apr 06, 2005 - 12:36pm  
 TIME PLOTTED: J:\2004\10704 - Route 91\Drawings\Landscap\10704PL.dwg  
 LAST REVISION: sseidmca

STATE OF CALIFORNIA - DEPARTMENT OF TRANSPORTATION  
**Caltrans** LANDSCAPE ARCHITECTURE  
 PROJECT LANDSCAPE ARCHITECT  
**IAN DAVIDSON LANDSCAPE ARCHITECTURE**  
 3744 TENTH STREET, SUITE 200, REDWOOD CITY, CALIFORNIA 94061  
 (650) 343-1000 FAX: (650) 343-1001

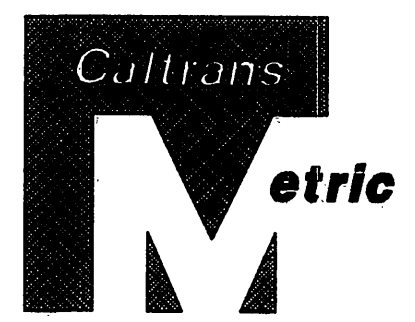

DIST	COUNTY	ROUTE	POST MILE PROJECT	TOTAL SHEET No	TOTAL SHEETS
08	Riv	91	-	12	14

LICENSED LANDSCAPE ARCHITECT

PLANS APPROVAL DATE

The State of California or its officers or agents shall not be responsible for the accuracy or completeness of electronic copies of this plan sheet.

Cal-Trans now has a web site! To get to the web site, go to: <http://tresp.dot.ca.gov>

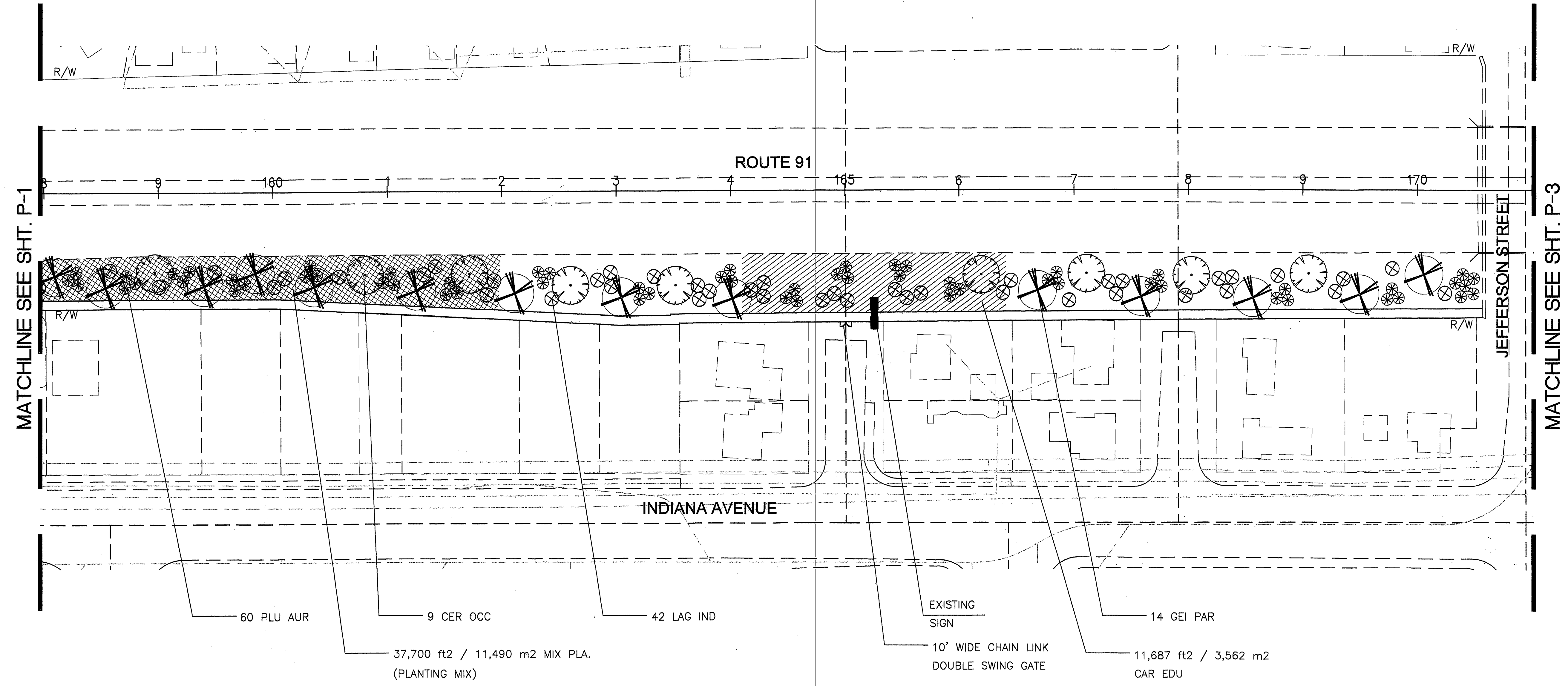

FOR REDUCED PLANS ORIGINAL SCALE IS IN MILLIMETERS

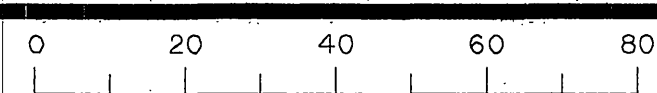

USERNAME:  
DGN FILE:

CU FED. EA NO.

EA STATE NO.

INDEXED 06-07-05 LH R-3842

DATE PLOTTED: Apr 06, 2005 - 12:39pm  
 TIME PLOTTED: J:\2004\10704 - Route 91\Drawings\Landscape\10704PL.dwg  
 LAST REVISION: essidmon

STATE OF CALIFORNIA - DEPARTMENT OF TRANSPORTATION  
**Caltrans** LANDSCAPE ARCHITECTURE  
 PROJECT LANDSCAPE ARCHITECT  
**IAN DAVIDSON LANDSCAPE ARCHITECTURE**  
 3744 TENTH STREET, SUITE 200 STREET, RIVERSIDE, CA 92501  
 (951) 685-1283 (951) 685-4522 FAX

x

x

x

x

x

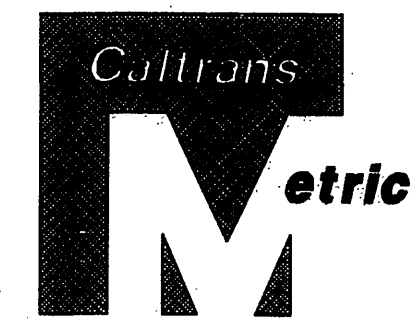

DIST	COUNTY	ROUTE	POST MILE PROJECT	TOTAL SHEET No	TOTAL SHEETS
08	Riv	91	-	13	14

LICENSED LANDSCAPE ARCHITECT

PLANS APPROVAL DATE

The State of California or its officers or agents shall not be responsible for the accuracy or completeness of electronic copies of this plan sheet.

Cal-Trans now has a web site! To get to the web site, go to: <http://fresc.dot.ca.gov>

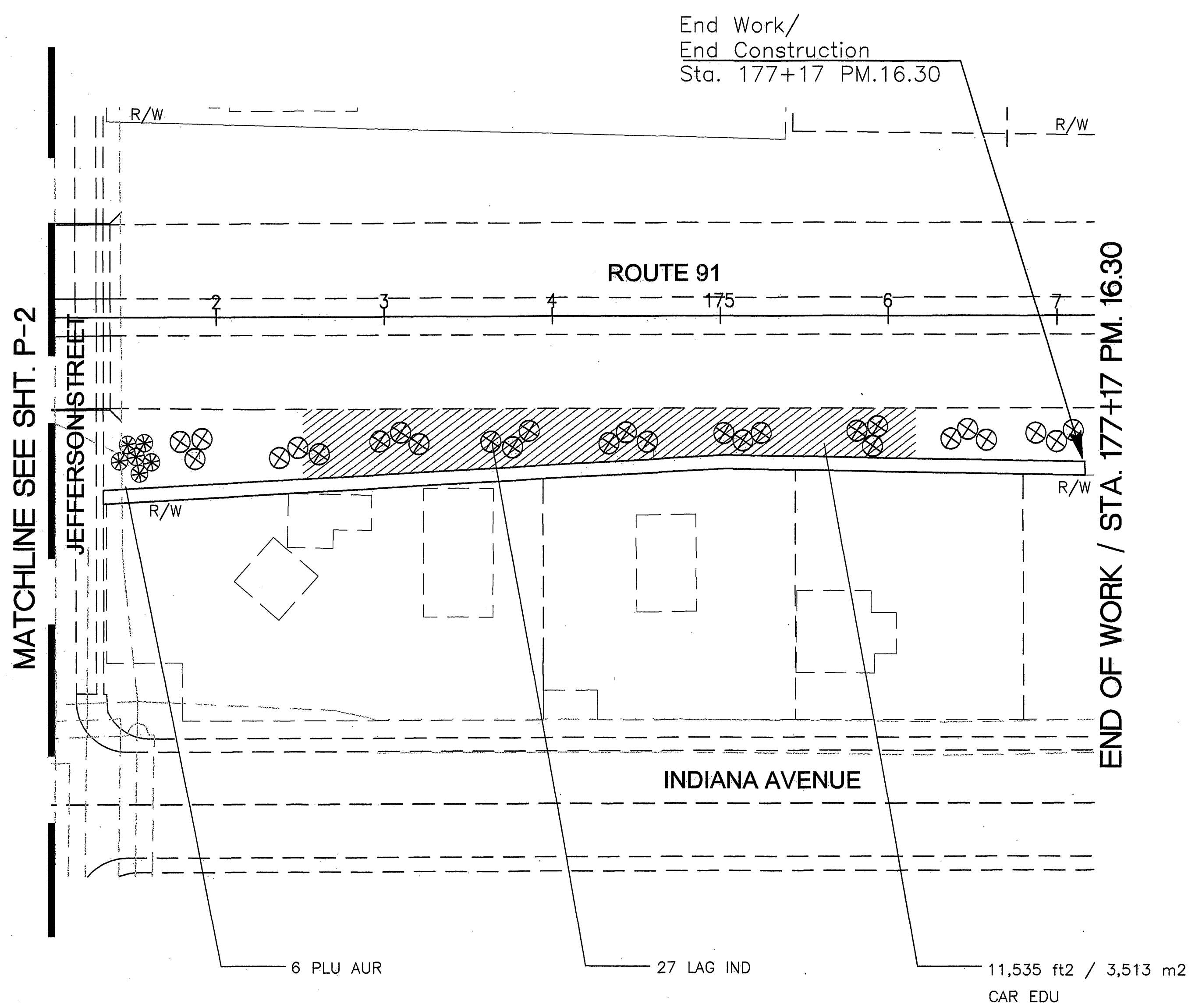
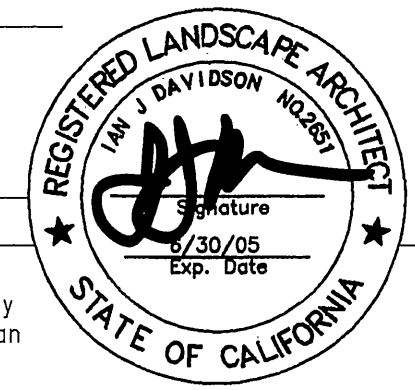

FOR REDUCED PLANS ORIGINAL SCALE IS IN MILLIMETERS

0 20 40 60 80

USERNAME: DGN FILE:



**PLANTING PLAN**  
 SCALE = 1:50/1:500  
**P-3**  
 PERMIT NUMBER 08-04-N-LF-1377

CU FED. EA NO. EA STATE NO.

INDEXED 06-07-05 LHH

R-3842

DATE PLOTTED: Apr 06, 2005 - 12:39pm  
 TIME PLOTTED: J:\2004\10704 - Route 91\Drawings\Landscapes\10704PL.dwg  
 sseidman



DIST	COUNTY	ROUTE	POST MILE PROJECT	TOTAL SHEET No	TOTAL SHEETS
08	Riv	91	-	14	14

LICENSED LANDSCAPE ARCHITECT

PLANS APPROVAL DATE

The State of California or its officers or agents shall not be responsible for the accuracy or completeness of electronic copies of this plan sheet.

Cal-Trans now has a web site! To get to the web site, go to: <http://fresc.dot.ca.gov>

## PLANT LIST AND PLANTING SPECIFICATIONS

PLANT GROUP	PLANT No	SYMBOL	BOTANICAL NAME	COMMON NAME	SIZE	QUANTITY EACH	HOLE SIZE (mm)		BASIN TYPE	IRON SULFATE ①	SOIL AMEND ①	COMMERCIAL FERTILIZER ①		MULCH ①	STAKING	PLANTING LIMITS						REMARKS	
							DIA	DEPTH				PLANTING	PLT ESTB			MINIMUM DISTANCE (m) FROM							
																TRVD WAY	PVMT	FENCE	WALL	PAVED DITCH	EARTH DITCH		ON CENTER (m)
K	1		GEIJERA PARVIFLORA	AUSTRALIAN WILLOW	24" Box	14	②		I			2 TABS	1/2 LB		⑥	9	-	3	3	3	3.5	④	TREE
	2		CERCIS OCCIDENTALIS	WESTERN REDBUD	36" Box	9	②		I			2 TABS	1/2 LB		⑥	-	4.5	4.5	4.5	4.5	4.5	④	TREE
B	3		PLUMBAGO AURICULATA	CAPE PLUMBAGO	5 GAL.	115	②		I			2 TABS	1/2 LB			-	4.5	4.5	4.5	4.5	5	④	SHRUB
U	4		LAGERSTROMIA INDICA	CRAPE MYRTLE	15 GAL.	103	②		I			2 TABS	1/2 LB			9	-	4.5	4.5	4.5	5	④	SHRUB
F	5		50% CARPOBROTUS EDULIS 25% LANTANA MONTEVIDENSIS 25% LONICERA JAPONICA	SEA FIG LANTANA HONEYSUCKLE	ROOTED CUTTINGS (FLATS)	37,700 SF / 11,491 SQm	⑦		I			15 LB/1000 SQFT	15 LB/1000 SQFT			-	2	2	2	2	2.5	0.5	GROUND COVER
	6		CARPOBROTUS EDULIS	SEA FIG	ROOTED CUTTINGS (FLATS)	23,222 SF / 7,078 SQm	⑦		I			15 LB/1000 SQFT	15 LB/1000 SQFT			-	2	2	2	2	2.5	0.5	GROUND COVER

NOTE:  
FOR PLANTING DETAILS REFER TO CALTRANS STD. PLAN #'S H-3, AND H-4.

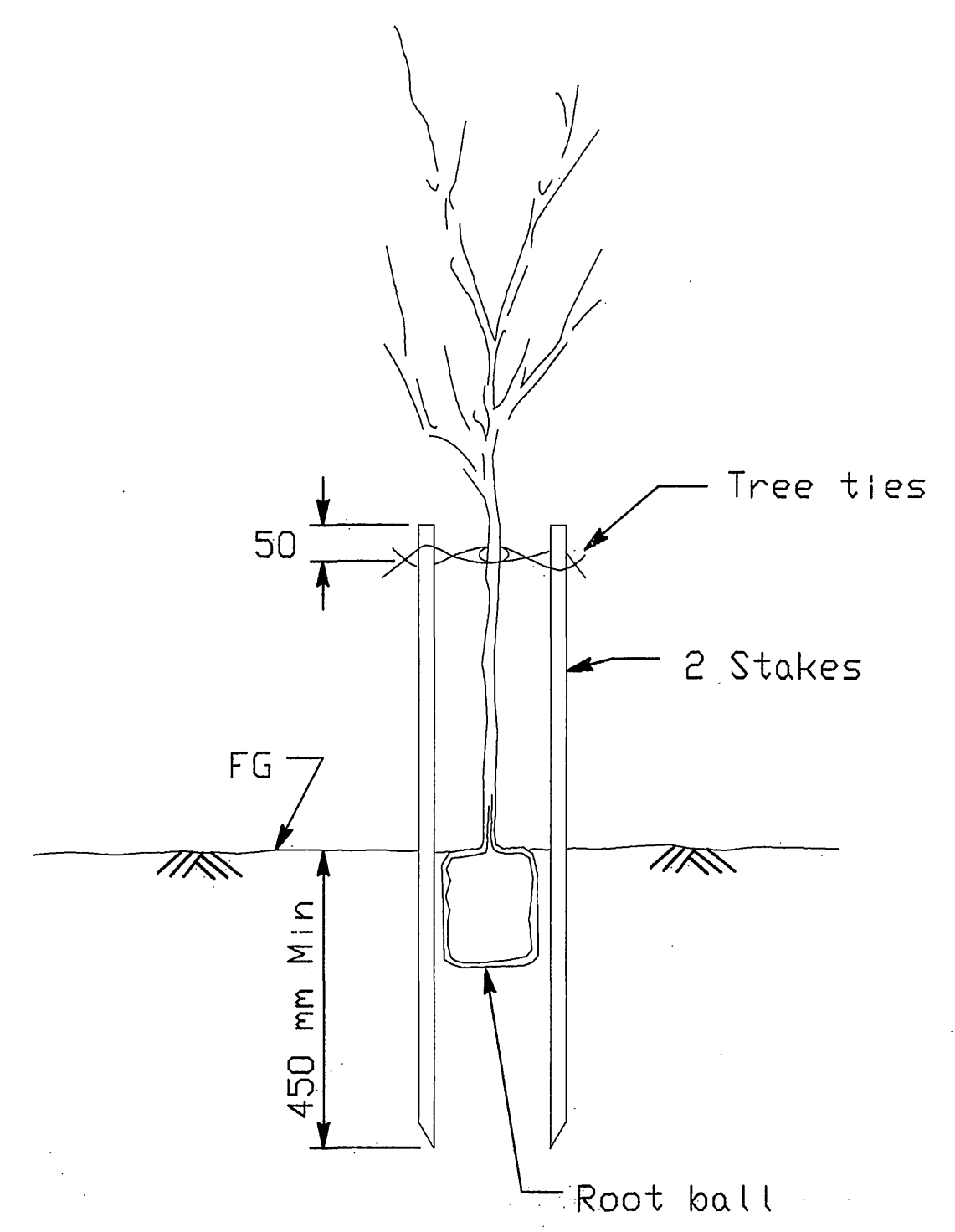

SECTION  
TREE STAKING

- APPLICABLE WHEN CIRCLED:**
- 1 - Quantities shown are "per plant" unless shown as sq application rates.
  - ② - Sufficient to receive root ball.
  - 3 - Does not apply to mulch areas.
  - ④ - As shown on plans.
  - 5 - Unless otherwise shown on plans.
  - ⑥ - See detail.
  - ⑦ - See Special Provisions.

**PLANTING LIST**  
NO SCALE **P-4**  
PERMIT NUMBER 08-04-N-LF-1377

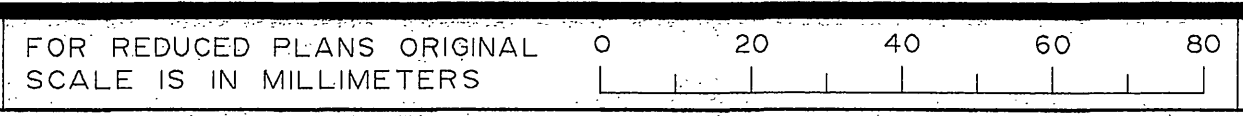

CU FED. EA NO.      EA STATE NO.

INDEXED 06-07-05 LHH R-3842

PROJECT LANDSCAPE ARCHITECT  
**IAN DAVIDSON LANDSCAPE ARCHITECTURE**  
 3744 TENTH STREET, SUITE 200 STREET, RIVERSIDE, CA 92501  
 (951) 505-1285 (951) 505-1872 FAX

STATE OF CALIFORNIA - DEPARTMENT OF TRANSPORTATION  
**Caltrans** LANDSCAPE ARCHITECTURE

DATE PLOTTED: Apr 06, 2005 - 12:39pm  
 TIME PLOTTED: J:\2004\10704 - Route 91\Drawings\Landscapes\10704PL.dwg  
 USERNAME: sseliman  
 DGN FILE: