

7 PARCELS
3 LETTERED LOTS
14.743 ACRES (GROSS)
14.350 ACRES (NET)

PARCEL MAP NO. 34605

BEING A SUBDIVISION OF A PORTION OF LOTS 1, 2 AND 3 OF BLOCK 51 OF LANDS OF RIVERSIDE LAND AND IRRIGATING COMPANY, AS PER MAP RECORDED IN BOOK 1, PAGE 72 OF MAPS, LOCATED IN PROTRACTED SECTION 22, T.3S., R.6W., IN RANCHO EL SOBRANTE DE SAN JACINTO, RECORDED IN BOOK 7, PAGE 10, MAPS IN THE OFFICE OF THE COUNTY RECORDER OF SAN BERNARDINO COUNTY.

BRIAN L. THIENES P.L.S. NO. 5750 MARCH, 2016
THIENES ENGINEERING LA MIRADA, CA

RECORDER'S STATEMENT:
FILED THIS 19th DAY OF March
2018, AT 12:42 PM BOOK 244
OF PARCEL MAPS, AT PAGES 61-65 AT
THE REQUEST OF THE CITY CLERK OF THE
CITY OF RIVERSIDE.
NO. 2018-0102082
FEE \$ 92.00
PETER ALDANA, ASSESSOR,
COUNTY CLERK AND RECORDER
BY: Alphie Gomez, DEPUTY
SUBDIVISION GUARANTEE: LAWYERS TITLE COMPANY

OWNER'S STATEMENT:

WE HEREBY STATE THAT WE ARE THE OWNERS OF, OR HAVE SOME RIGHT, TITLE, OR INTEREST IN THE LAND INCLUDED WITHIN THE SUBDIVISION AS SHOWN ON THE ANNEXED MAP; THAT WE ARE THE ONLY PERSONS WHOSE CONSENT IS NECESSARY TO PASS CLEAR TITLE TO SAID LAND, AND WE CONSENT TO THE PREPARATION AND RECORDATION OF THIS SUBDIVISION MAP AS SHOWN WITHIN THE DISTINCTIVE BORDER LINE.

WE HEREBY DEDICATE TO PUBLIC USE FOR PUBLIC STREET AND PUBLIC UTILITY PURPOSES, LOTS "A" THROUGH "C", INCLUSIVE.

WE HEREBY DEDICATE TO THE CITY OF RIVERSIDE AS AN EASEMENT FOR THE CONSTRUCTION AND MAINTENANCE OF ELECTRIC ENERGY DISTRIBUTION AND TELECOMMUNICATION FACILITIES, THE EASEMENTS DESIGNATED AS "BLANKET P.U.E" ON ALL PARCELS.

WE HEREBY DEDICATE TO THE CITY OF RIVERSIDE AS AN EASEMENT FOR THE CONSTRUCTION AND MAINTENANCE OF SANITARY SEWER FACILITIES, THE EASEMENTS DESIGNATED AS "20' SEWER EASEMENT".

WE HEREBY RESERVE FOR OURSELVES, HEIRS AND ASSIGNS, THE FOLLOWING:

A PRIVATE EASEMENT DESIGNATED AS ② FOR DETENTION BASIN PURPOSES OVER PARCEL 1 FOR THE BENEFIT OF PARCEL 3.

A PRIVATE EASEMENT DESIGNATED AS ③ FOR DETENTION BASIN PURPOSES OVER PARCEL 2 FOR THE BENEFIT OF PARCEL 5 & 6.

A PRIVATE EASEMENT DESIGNATED AS ④ FOR DETENTION BASIN AND STORM DRAIN PURPOSES OVER PARCEL 1 FOR THE BENEFIT OF PARCEL 2.

A PRIVATE 10' WIDE EASEMENT DESIGNATED AS ⑤ FOR WATER PURPOSES OVER PARCEL 2 FOR THE BENEFIT OF PARCELS 1, 3, AND 4.

A PRIVATE 10' WIDE EASEMENT DESIGNATED AS ⑥ FOR STORM DRAIN PURPOSES OVER PARCEL 5 FOR THE BENEFIT OF PARCELS 6 & 7.

A PRIVATE 10 WIDE EASEMENT DESIGNATED AS ⑦ FOR STORM DRAIN PURPOSES OVER PARCEL 6 FOR THE BENEFIT OF PARCEL 7.

A PRIVATE 20' WIDE EASEMENT DESIGNATED AS ⑧ FOR STORM DRAIN PURPOSES OVER PARCEL 5 FOR THE BENEFIT OF PARCELS 6 & 7.

A PRIVATE 10' WIDE EASEMENT DESIGNATED AS ⑨ FOR STORM DRAIN PURPOSES OVER PARCEL 4 FOR THE BENEFIT OF PARCELS 5, 6 & 7.

A PRIVATE EASEMENT DESIGNATED AS ⑩ FOR STORM DRAIN PURPOSES OVER PARCEL 3 FOR THE BENEFIT OF PARCELS 4, 5, 6, & 7.

A PRIVATE 10' WIDE EASEMENT DESIGNATED AS ⑪ FOR STORM DRAIN PURPOSES OVER PARCEL 4 FOR THE BENEFIT OF PARCEL 2.

A PRIVATE 10' WIDE EASEMENT DESIGNATED AS ⑫ FOR STORM DRAIN PURPOSES OVER PARCEL 3 FOR THE BENEFIT OF PARCEL 2.

A PRIVATE EASEMENT DESIGNATED AS ⑬ FOR DETENTION BASIN PURPOSES OVER PARCEL 5 FOR THE BENEFIT OF PARCEL 7.

A PRIVATE EASEMENT DESIGNATED AS ⑭ FOR DETENTION BASIN PURPOSES OVER PARCEL 5 FOR THE BENEFIT OF PARCELS 6 AND 7.

A PRIVATE EASEMENT DESIGNATED AS ⑮ FOR DETENTION BASIN PURPOSES OVER PARCEL 5 FOR THE BENEFIT OF PARCEL 4.

A PRIVATE EASEMENT DESIGNATED AS ⑯ FOR DETENTION BASIN PURPOSES OVER PARCEL 5 FOR THE BENEFIT OF PARCEL 6.

A PRIVATE 10' WIDE EASEMENT DESIGNATED AS ⑰ FOR WATER PURPOSES OVER PARCEL 4 FOR THE BENEFIT OF PARCELS 1 & 3.

A PRIVATE 10' WIDE EASEMENT DESIGNATED AS ⑱ FOR WATER PURPOSES OVER PARCEL 4 FOR THE BENEFIT OF PARCEL 1.

A PRIVATE 5' WIDE EASEMENT DESIGNATED AS ⑲ FOR WATER PURPOSES OVER PARCEL 6 FOR THE BENEFIT OF PARCEL 7.

A PRIVATE 3' WIDE EASEMENT DESIGNATED AS ⑳ FOR BUILDING MAINTENANCE PURPOSES OVER PARCEL 5 FOR THE BENEFIT OF PARCEL 2.

58 MAGNOLIA PARTNERSHIP, L.P., A CALIFORNIA LIMITED PARTNERSHIP

BY: INVESTMENT BUILDING GROUP, A CALIF. CORP., GENERAL PARTNER

PRINT NAME: of: Jack M. Langson

PRINT TITLE: JACK M. LANGSON, PRESIDENT

CITY CLERK'S CERTIFICATE:

RESOLVED: THAT THIS MAP CONSISTING OF 5 SHEETS BE, AND THE SAME IS HEREBY ACCEPTED AS THE FINAL MAP OF PARCEL MAP NO. 34605.

LOTS "A" THROUGH "C", INCLUSIVE ARE HEREBY ACCEPTED FOR PUBLIC STREET PURPOSES SUBJECT TO THE INSTALLATION OF IMPROVEMENTS TO THE SATISFACTION OF THE PUBLIC WORKS DIRECTOR OF THE CITY OF RIVERSIDE.

LOTS "A" THROUGH "C", INCLUSIVE ARE HEREBY ACCEPTED FOR PUBLIC UTILITY PURPOSES AND OTHER PUBLIC SERVICES.

THE EASEMENTS DESIGNATED AS "BLANKET P.U.E." ARE HEREBY ACCEPTED AS EASEMENTS FOR THE CONSTRUCTION AND MAINTENANCE OF ELECTRIC ENERGY DISTRIBUTION AND TELECOMMUNICATION FACILITIES.

THE EASEMENTS DESIGNATED AS "20' SEWER EASEMENT" ARE HEREBY ACCEPTED AS EASEMENTS FOR THE CONSTRUCTION AND MAINTENANCE OF SANITARY SEWER FACILITIES.

THE CITY CLERK IS HEREBY AUTHORIZED AND DIRECTED TO ATTEST SAID MAP BY SIGNING HER NAME THERETO AS CITY CLERK OF THE CITY OF RIVERSIDE, STATE OF CALIFORNIA.

I HEREBY CERTIFY THAT THE FOREGOING RESOLUTION WAS ACCEPTED BY THE MAYOR AND COUNCIL OF THE CITY OF RIVERSIDE THIS 6th DAY OF March, 2018.

COLLEEN J. NICOL
CITY CLERK OF THE CITY OF RIVERSIDE, CALIFORNIA

BY: [Signature]

SURVEYOR'S STATEMENT:

THIS MAP WAS PREPARED BY ME OR UNDER MY DIRECTION AND IS BASED UPON A FIELD SURVEY IN CONFORMANCE WITH THE REQUIREMENTS OF THE SUBDIVISION MAP ACT AND LOCAL ORDINANCE AT THE REQUEST OF 58 MAGNOLIA PARTNERSHIP, ON FEBRUARY 17 2016. I HEREBY STATE THAT THIS PARCEL MAP SUBSTANTIALLY CONFORMS TO THE APPROVED OR CONDITIONALLY APPROVED TENTATIVE MAP IF ANY. I HEREBY STATE THAT ALL MONUMENTS ARE OF THE CHARACTER AND OCCUPY THE POSITIONS INDICATED OR THAT THEY WILL BE SET IN THOSE POSITIONS BEFORE MARCH 30, 2019 AND THAT THE MONUMENTS ARE, OR WILL BE SUFFICIENT TO ENABLE THE SURVEY TO BE RETRACED. THE SURVEY IS TRUE AND COMPLETE AS SHOWN.

[Signature] 1/18/18
DATE
BRIAN L. THIENES
P.L.S. NO. 5750
REG. EXPIRES 12/31/19



CITY ENGINEER'S STATEMENT:

I HEREBY STATE THAT I HAVE EXAMINED THIS MAP, THAT THE SUBDIVISION AS SHOWN HEREON IS SUBSTANTIALLY THE SAME AS IT APPEARS ON THE TENTATIVE MAP OF PARCEL MAP NO. 34605 WHICH WAS APPROVED BY THE CITY OF RIVERSIDE ZONING ADMINISTRATION ON FEBRUARY 22, 2017 AND ANY APPROVED ALTERATIONS THEREOF; AND ALL PROVISIONS OF THE SUBDIVISION MAP ACT (DIVISION 2 OF TITLE 7 OF THE CALIFORNIA GOVERNMENT CODE) AND TITLE 18 OF THE RIVERSIDE MUNICIPAL CODE APPLICABLE AT THE TIME OF THE APPROVAL OF THE TENTATIVE MAP HAVE BEEN COMPLIED WITH.

MARK ANDREW STEUER, R.C.E. 53672
LIC. EXP. 6/30/19
CITY ENGINEER

BY: [Signature] DATE: 1/30/17



CITY SURVEYOR'S STATEMENT:

I HEREBY STATE THAT I HAVE EXAMINED THIS MAP, AND THAT I AM SATISFIED THAT THE MAP IS TECHNICALLY CORRECT, AND THAT ALL MONUMENTS HAVE BEEN SET OR A CASH DEPOSIT SUFFICIENT TO COVER THEIR PLACEMENT HAS BEEN DEPOSITED WITH THE CITY OF RIVERSIDE.

CURTIS C. STEPHENS, L.S. 7519
LIC. EXP. 12/31/19
CITY SURVEYOR

BY: [Signature] DATE: 1/30/18



CITY TREASURER'S CERTIFICATE:

I HEREBY CERTIFY THAT ACCORDING TO THE RECORDS OF THIS OFFICE AS OF THIS DATE, THE REAL PROPERTY SHOWN ON THIS MAP IS NOT SUBJECT TO ANY SPECIAL ASSESSMENTS, BONDS, AND/OR LIENS WHICH HAVE NOT BEEN PAID IN FULL EXCEPT FOR THOSE NOTED BELOW.
None noted.

THIS CERTIFICATE DOES NOT INCLUDE ANY SPECIAL ASSESSMENTS, THE BONDS OF WHICH HAVE NOT BECOME A LIEN UPON SAID PROPERTY, OR ANY SPECIAL ASSESSMENTS, BONDS, AND/OR LIENS RELATED TO SPECIAL DISTRICTS LOCATED WITHIN THE CITY OF RIVERSIDE THAT ARE NOT ADMINISTERED BY THE CITY.

DATE: 1/29/2018 ADAM RAYMOND
CHIEF FINANCIAL OFFICER/CITY TREASURER

BY: [Signature]

TAX BOND CERTIFICATE:

I HEREBY CERTIFY THAT A BOND IN THE SUM OF \$ 79,700.00 HAS BEEN EXECUTED AND FILED WITH THE BOARD OF SUPERVISORS OF THE COUNTY OF RIVERSIDE, CALIFORNIA, CONDITIONED UPON THE PAYMENT OF ALL TAXES, STATE, COUNTY, MUNICIPAL, OR LOCAL AND ALL SPECIAL ASSESSMENTS COLLECTED AS TAXES, WHICH AT THE TIME OF FILING OF THIS MAP WITH THE COUNTY RECORDER ARE A LIEN AGAINST SAID PROPERTY BUT NOT YET PAYABLE AND SAID BOND HAS BEEN DULY APPROVED BY SAID BOARD OF SUPERVISORS.

CASH OR SURETY TAX BOND
JOHN CHRISTENSEN
COUNTY TAX COLLECTOR

DATE: 3-13-2018 BY: [Signature], DEPUTY

TAX COLLECTOR'S CERTIFICATE:

I HEREBY CERTIFY THAT ACCORDING TO THE RECORDS OF THIS OFFICE, AS OF THIS DATE, THERE ARE NO LIENS AGAINST THE PROPERTY SHOWN ON THE WITHIN MAP FOR UNPAID STATE, COUNTY, MUNICIPAL OR LOCAL TAXES OR SPECIAL ASSESSMENTS COLLECTED AS TAXES, EXCEPT TAXES OR SPECIAL ASSESSMENTS COLLECTED AS TAXES NOW A LIEN BUT NOT YET PAYABLE, WHICH ARE ESTIMATED TO BE \$ 79,700.00.

JOHN CHRISTENSEN
COUNTY TAX COLLECTOR

DATE: 3-13-2018 BY: [Signature], DEPUTY

19/24/21
COPY

Copy 2/14/12/162

IN THE CITY OF RIVERSIDE, COUNTY OF RIVERSIDE, STATE OF CALIFORNIA

PARCEL MAP NO. 34605

BEING A SUBDIVISION OF A PORTION OF LOTS 1, 2 AND 3 OF BLOCK 51 OF LANDS OF RIVERSIDE LAND AND IRRIGATING COMPANY, AS PER MAP RECORDED IN BOOK 1, PAGE 72 OF MAPS, LOCATED IN PROTRACTED SECTION 22, T.3S., R.6W., IN RANCHO EL SOBRANTE DE SAN JACINTO, RECORDED IN BOOK 7, PAGE 10, MAPS IN THE OFFICE OF THE COUNTY RECORDER OF SAN BERNARDINO COUNTY.

BRIAN L. THIENES P.L.S. NO. 5750 MARCH, 2016
THIENES ENGINEERING LA MIRADA, CA

PUBLIC UTILITIES CERTIFICATE:

I HEREBY CERTIFY THAT THE SUBDIVIDER NAMED ON THIS MAP HAS DEPOSITED WITH THE CITY OF RIVERSIDE PUBLIC UTILITIES DEPARTMENT SUFFICIENT FUNDS OR MADE THE REQUIRED ARRANGEMENTS AND PROVISIONS FOR THE INSTALLATION OF WATER AND ELECTRIC FACILITIES NECESSARY TO PROVIDE SERVICE TO ALL PARCELS AS SHOWN ON THIS MAP; AND THAT ALL PUBLIC UTILITY EASEMENTS SHOWN ARE SUFFICIENT FOR ALL REQUIREMENTS OF THE WATER AND ELECTRIC DIVISIONS OF THE PUBLIC UTILITIES DEPARTMENT OF THE CITY OF RIVERSIDE.

Todd L. Jorgenson
PUBLIC UTILITIES GENERAL MANAGER

DATE: 1/29/2018

BY: Todd L. Jorgenson

SIGNATURE OMISSIONS:

PURSUANT TO SECTION 66436 OF THE SUBDIVISION MAP ACT OF THE STATE OF CALIFORNIA, THE SIGNATURES OF THE FOLLOWING EASEMENT HOLDERS HAVE BEEN OMITTED SINCE THEIR INTERESTS CANNOT RIPEN INTO A FEE:

SOUTHERN CALIFORNIA GAS COMPANY, A CORPORATION AND SOUTHERN COUNTIES GAS COMPANY OF CALIFORNIA, HOLDER OF AN EASEMENT FOR TRANSPORTATION OF GAS AND INCIDENTAL PURPOSES RECORDED MAY 1, 1948 IN BOOK 904, PAGE 528 OF OFFICIAL RECORDS OF RIVERSIDE COUNTY.

CITY OF RIVERSIDE, A MUNICIPAL CORPORATION, HOLDER OF AN EASEMENT FOR SANITARY SEWER FACILITIES AND INCIDENTAL PURPOSES RECORDED NOVEMBER 18, 1983 AS INSTRUMENT NO. 241684 OF OFFICIAL RECORDS OF RIVERSIDE COUNTY.

SOUTHERN CALIFORNIA GAS COMPANY, HOLDER OF AN EASEMENT FOR PIPELINES, CONDUITS AND INCIDENTAL PURPOSES RECORDED FEBRUARY 22, 2018 AS INSTRUMENT NO. 2018-065489 OF OFFICIAL RECORDS OF RIVERSIDE COUNTY.

NOTARY ACKNOWLEDGMENT:

A NOTARY PUBLIC OR OTHER OFFICER COMPLETING THIS CERTIFICATE VERIFIES ONLY THE IDENTITY OF THE INDIVIDUAL WHO SIGNED THE DOCUMENT TO WHICH THIS CERTIFICATE IS ATTACHED, AND NOT THE TRUTHFULNESS, ACCURACY, OR VALIDITY OF THAT DOCUMENT.

STATE OF CALIFORNIA)
COUNTY OF ORANGE) ss

ON 1-22-18 BEFORE ME M. SKAWINSKI, NOTARY PUBLIC
(INSERT NAME AND TITLE OF THE OFFICER)

PERSONALLY APPEARED JACK M. LANGSON
WHO PROVED TO ME ON THE BASIS OF SATISFACTORY EVIDENCE TO BE THE PERSON(S) WHOSE NAME(S) IS/ARE SUBSCRIBED TO THE WITHIN INSTRUMENT AND ACKNOWLEDGED TO ME THAT HE/SHE/THEY EXECUTED THE SAME IN HIS/HER/THEIR AUTHORIZED CAPACITY(IES), AND THAT BY HIS/HER/THEIR SIGNATURE(S) ON THE INSTRUMENT THE PERSON(S), OR THE ENTITY ON BEHALF OF WHICH THE PERSONS(S) ACTED, EXECUTED THE INSTRUMENT.

I CERTIFY UNDER PENALTY OF PERJURY UNDER THE LAWS OF THE STATE OF CALIFORNIA THAT THE FOREGOING PARAGRAPH IS TRUE AND CORRECT.

WITNESS MY HAND:

M. Skawinski #2136721
SIGNATURE MY COMMISSION NUMBER
M. SKAWINSKI MY COMMISSION EXPIRES 12-13-19
PRINT NAME

MY PRINCIPAL PLACE OF BUSINESS IS IN: ORANGE COUNTY.

SOILS REPORT:

A PRELIMINARY SOILS REPORT WAS PREPARED FOR THIS SUBDIVISION BY JOHN R. BYERLY INCORPORATED ON MARCH 10, 2017 AS REQUIRED BY THE HEALTH AND SAFETY CODE OF THE STATE OF CALIFORNIA, SECTION 17953.

UTILITIES EASEMENT STATEMENT:

THE CITY OF RIVERSIDE BEING THE RECORD OWNER OF THE FOLLOWING DESCRIBED EASEMENTS HEREBY CONSENTS TO THE MAKING AND FILING OF THE ANNEXED MAP.

RIVERSIDE WATER COMPANY, A CORPORATION, HOLDER OF AN EASEMENT FOR A RIGHT OF ENTRY UPON AND RIGHT OF WAY FOR ALL WATER PIPES, DITCHES AND OTHER CONDUITS RECORDED AUGUST 14, 1885 IN BOOK 42, PAGE 296 OF OFFICIAL RECORDS OF RIVERSIDE COUNTY.

DATE: 1/29/2018

Todd L. Jorgenson
PUBLIC UTILITIES GENERAL MANAGER
BY: Todd L. Jorgenson

COPY 2/14/03

PARCEL MAP NO. 34605

IN THE CITY OF RIVERSIDE, COUNTY OF RIVERSIDE, STATE OF CALIFORNIA
 BEING A SUBDIVISION OF A PORTION OF LOTS 1, 2 AND 3 OF BLOCK 51 OF LANDS OF RIVERSIDE LAND AND IRRIGATING COMPANY, AS PER MAP RECORDED IN BOOK 1, PAGE 72 OF MAPS, LOCATED IN PROTRACTED SECTION 22, T.3S., R.6W., IN RANCHO EL SOBRANTE DE SAN JACINTO, RECORDED IN BOOK 7, PAGE 10, MAPS IN THE OFFICE OF THE COUNTY RECORDER OF SAN BERNARDINO COUNTY.

BRIAN L. THIENES P.L.S. NO. 5750 MARCH, 2016
 THIENES ENGINEERING LA MIRADA, CA

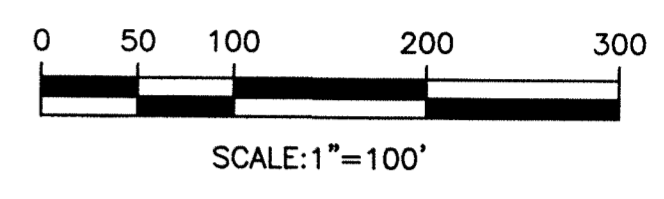
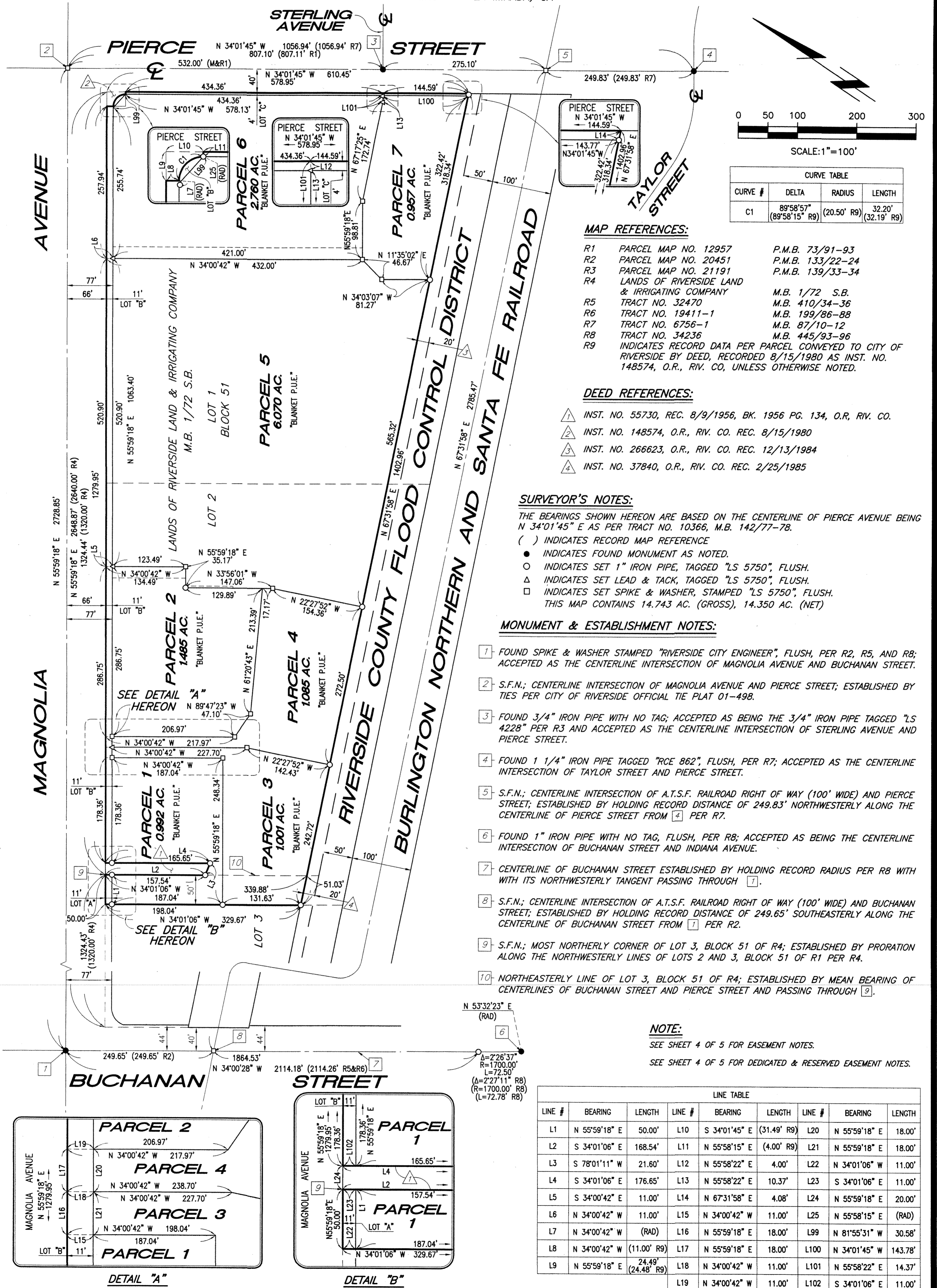

CURVE TABLE			
CURVE #	DELTA	RADIUS	LENGTH
C1	89°58'57" (89°58'15" R9)	(20.50' R9)	32.20' (32.19' R9)

MAP REFERENCES:

- R1 PARCEL MAP NO. 12957 P.M.B. 73/91-93
- R2 PARCEL MAP NO. 20451 P.M.B. 133/22-24
- R3 PARCEL MAP NO. 21191 P.M.B. 139/33-34
- R4 LANDS OF RIVERSIDE LAND & IRRIGATING COMPANY M.B. 1/72 S.B.
- R5 TRACT NO. 32470 M.B. 410/34-36
- R6 TRACT NO. 19411-1 M.B. 199/86-88
- R7 TRACT NO. 6756-1 M.B. 87/10-12
- R8 TRACT NO. 34236 M.B. 445/93-96
- R9 INDICATES RECORD DATA PER PARCEL CONVEYED TO CITY OF RIVERSIDE BY DEED, RECORDED 8/15/1980 AS INST. NO. 148574, O.R., RIV. CO, UNLESS OTHERWISE NOTED.

DEED REFERENCES:

- 1 INST. NO. 55730, REC. 8/9/1956, BK. 1956 PG. 134, O.R. RIV. CO.
- 2 INST. NO. 148574, O.R., RIV. CO. REC. 8/15/1980
- 3 INST. NO. 266623, O.R., RIV. CO. REC. 12/13/1984
- 4 INST. NO. 37840, O.R., RIV. CO. REC. 2/25/1985

SURVEYOR'S NOTES:

THE BEARINGS SHOWN HEREON ARE BASED ON THE CENTERLINE OF PIERCE AVENUE BEING N 34°01'45" E AS PER TRACT NO. 10366, M.B. 142/77-78.
 () INDICATES RECORD MAP REFERENCE
 ● INDICATES FOUND MONUMENT AS NOTED.
 ○ INDICATES SET 1" IRON PIPE, TAGGED "LS 5750", FLUSH.
 △ INDICATES SET LEAD & TACK, TAGGED "LS 5750", FLUSH.
 □ INDICATES SET SPIKE & WASHER, STAMPED "LS 5750", FLUSH.
 THIS MAP CONTAINS 14.743 AC. (GROSS), 14.350 AC. (NET)

MONUMENT & ESTABLISHMENT NOTES:

- 1 FOUND SPIKE & WASHER STAMPED "RIVERSIDE CITY ENGINEER", FLUSH, PER R2, R5, AND R8; ACCEPTED AS THE CENTERLINE INTERSECTION OF MAGNOLIA AVENUE AND BUCHANAN STREET.
- 2 S.F.N.; CENTERLINE INTERSECTION OF MAGNOLIA AVENUE AND PIERCE STREET; ESTABLISHED BY TIES PER CITY OF RIVERSIDE OFFICIAL TIE PLAT 01-498.
- 3 FOUND 3/4" IRON PIPE WITH NO TAG; ACCEPTED AS BEING THE 3/4" IRON PIPE TAGGED "LS 4228" PER R3 AND ACCEPTED AS THE CENTERLINE INTERSECTION OF STERLING AVENUE AND PIERCE STREET.
- 4 FOUND 1 1/4" IRON PIPE TAGGED "RCE 862", FLUSH, PER R7; ACCEPTED AS THE CENTERLINE INTERSECTION OF TAYLOR STREET AND PIERCE STREET.
- 5 S.F.N.; CENTERLINE INTERSECTION OF A.T.S.F. RAILROAD RIGHT OF WAY (100' WIDE) AND PIERCE STREET; ESTABLISHED BY HOLDING RECORD DISTANCE OF 249.83' NORTHWESTERLY ALONG THE CENTERLINE OF PIERCE STREET FROM 4 PER R7.
- 6 FOUND 1" IRON PIPE WITH NO TAG, FLUSH, PER R8; ACCEPTED AS BEING THE CENTERLINE INTERSECTION OF BUCHANAN STREET AND INDIANA AVENUE.
- 7 CENTERLINE OF BUCHANAN STREET ESTABLISHED BY HOLDING RECORD RADIUS PER R8 WITH ITS NORTHWESTERLY TANGENT PASSING THROUGH 7.
- 8 S.F.N.; CENTERLINE INTERSECTION OF A.T.S.F. RAILROAD RIGHT OF WAY (100' WIDE) AND BUCHANAN STREET; ESTABLISHED BY HOLDING RECORD DISTANCE OF 249.65' SOUTHEASTERLY ALONG THE CENTERLINE OF BUCHANAN STREET FROM 7 PER R2.
- 9 S.F.N.; MOST NORTHERLY CORNER OF LOT 3, BLOCK 51 OF R4; ESTABLISHED BY PRORATION ALONG THE NORTHWESTERLY LINES OF LOTS 2 AND 3, BLOCK 51 OF R1 PER R4.
- 10 NORTHEASTERLY LINE OF LOT 3, BLOCK 51 OF R4; ESTABLISHED BY MEAN BEARING OF CENTERLINES OF BUCHANAN STREET AND PIERCE STREET AND PASSING THROUGH 9.

NOTE:

SEE SHEET 4 OF 5 FOR EASEMENT NOTES.
 SEE SHEET 4 OF 5 FOR DEDICATED & RESERVED EASEMENT NOTES.

LINE TABLE								
LINE #	BEARING	LENGTH	LINE #	BEARING	LENGTH	LINE #	BEARING	LENGTH
L1	N 55°59'18" E	50.00'	L10	S 34°01'45" E	(31.49' R9)	L20	N 55°59'18" E	18.00'
L2	S 34°01'06" E	168.54'	L11	N 55°58'15" E	(4.00' R9)	L21	N 55°59'18" E	18.00'
L3	S 78°01'11" W	21.60'	L12	N 55°58'22" E	4.00'	L22	N 34°01'06" W	11.00'
L4	S 34°01'06" E	176.65'	L13	N 55°58'22" E	10.37'	L23	S 34°01'06" E	11.00'
L5	S 34°00'42" E	11.00'	L14	N 67°31'58" E	4.08'	L24	N 55°59'18" E	20.00'
L6	N 34°00'42" W	11.00'	L15	N 34°00'42" W	11.00'	L25	N 55°58'15" E	(RAD)
L7	N 34°00'42" W	(RAD)	L16	N 55°59'18" E	18.00'	L99	N 81°55'31" W	30.58'
L8	N 34°00'42" W	(11.00' R9)	L17	N 55°59'18" E	18.00'	L100	N 34°01'45" W	143.78'
L9	N 55°59'18" E	24.49' (24.48' R9)	L18	N 34°00'42" W	11.00'	L101	N 55°58'22" E	14.37'
			L19	N 34°00'42" W	11.00'	L102	S 34°01'06" E	11.00'

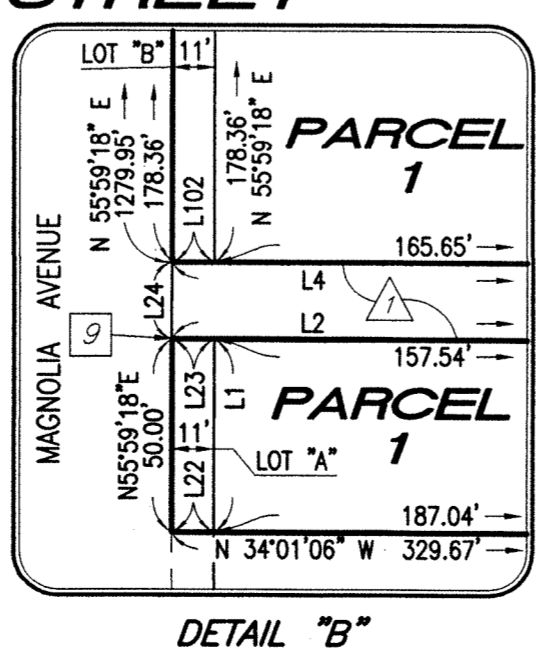
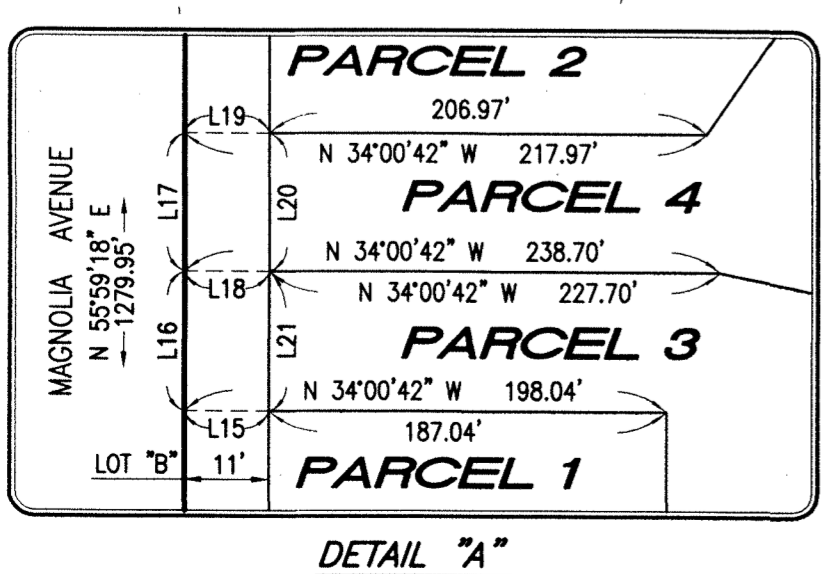

PARCEL MAP NO. 34605

BEING A SUBDIVISION OF A PORTION OF LOTS 1, 2 AND 3 OF BLOCK 51 OF LANDS OF RIVERSIDE LAND AND IRRIGATING COMPANY, AS PER MAP RECORDED IN BOOK 1, PAGE 72 OF MAPS, LOCATED IN PROTRACTED SECTION 22, T.3S., R.6W., IN RANCHO EL SOBRANTE DE SAN JACINTO, RECORDED IN BOOK 7, PAGE 10, MAPS IN THE OFFICE OF THE COUNTY RECORDER OF SAN BERNARDINO COUNTY.

BRIAN L. THIENES P.L.S. NO. 5750 MARCH, 2016
THIENES ENGINEERING LA MIRADA, CA

EASEMENT NOTES:

- ① AN EASEMENT FOR TRANSPORTATION OF GAS AND INCIDENTAL PURPOSES IN FAVOR OF SOUTHERN CALIFORNIA GAS COMPANY, A CORPORATION AND SOUTHERN COUNTIES GAS COMPANY OF CALIFORNIA, RECORDED MAY 1, 1948 IN BOOK 904, PAGE 528 OF OFFICIAL RECORDS OF RIVERSIDE COUNTY.
- ② AN EASEMENT FOR SANITARY SEWER FACILITIES AND INCIDENTAL PURPOSES IN FAVOR OF CITY OF RIVERSIDE, A MUNICIPAL CORPORATION, RECORDED NOVEMBER 18, 1983 AS INSTRUMENT NO. 241684 OF OFFICIAL RECORDS OF RIVERSIDE COUNTY.
- ③ AN EASEMENT FOR A RIGHT OF ENTRY UPON AND RIGHT OF WAY FOR ALL WATER PIPES, DITCHES AND OTHER CONDUITS IN FAVOR OF RIVERSIDE WATER COMPANY, A CORPORATION, RECORDED AUGUST 14, 1885 IN BOOK 42, PAGE 296 OF OFFICIAL RECORDS OF RIVERSIDE COUNTY. (SAID EASEMENT CANNOT BE PLOTTED FROM RECORD INFORMATION)
- ④ AN EASEMENT FOR PIPELINES, CONDUITS AND INCIDENTAL PURPOSES IN FAVOR OF SOUTHERN CALIFORNIA GAS COMPANY, RECORDED FEBRUARY 22, 2018 AS INSTRUMENT NO. 2018-065489 OF OFFICIAL RECORDS OF RIVERSIDE COUNTY. EXCLUSIVE EASEMENT PLOTTED HEREON AS ④A. NON-EXCLUSIVE EASEMENT PLOTTED HEREON AS ④B.

DEDICATED AND RESERVED EASEMENT NOTES:

- ① 20' WIDE SEWER EASEMENT.
- ② AN EASEMENT FOR DETENTION BASIN PURPOSES OVER PARCEL 1 FOR THE BENEFIT OF PARCEL 3.
- ③ A PRIVATE EASEMENT FOR DETENTION BASIN PURPOSES OVER PARCEL 2 FOR THE BENEFIT OF PARCELS 5 & 6.
- ④ A PRIVATE EASEMENT FOR DETENTION BASIN AND STORM DRAIN PURPOSES OVER PARCEL 1 FOR THE BENEFIT OF PARCEL 2.
- ⑤ A 10' WIDE PRIVATE EASEMENT FOR WATER PURPOSES OVER PARCEL 2 FOR THE BENEFIT OF PARCELS 1, 3, AND 4.
- ⑥ A 10' WIDE PRIVATE EASEMENT FOR STORM DRAIN PURPOSES OVER PARCEL 5 FOR THE BENEFIT OF PARCELS 6 & 7.
- ⑦ A 10' WIDE PRIVATE EASEMENT FOR STORM DRAIN PURPOSES OVER PARCEL 6 FOR THE BENEFIT OF PARCEL 7.
- ⑧ A 20' WIDE PRIVATE EASEMENT FOR STORM DRAIN PURPOSES OVER PARCEL 5 FOR THE BENEFIT OF PARCELS 6 & 7.
- ⑨ A 10' WIDE PRIVATE EASEMENT FOR STORM DRAIN PURPOSES OVER PARCEL 4 FOR THE BENEFIT OF PARCELS 5, 6 & 7.
- ⑩ A 10' WIDE PRIVATE EASEMENT FOR STORM DRAIN PURPOSES OVER PARCEL 3 FOR THE BENEFIT OF PARCELS 4, 5, 6, & 7.
- ⑪ A 10' WIDE PRIVATE EASEMENT FOR STORM DRAIN PURPOSES OVER PARCEL 4 FOR THE BENEFIT OF PARCEL 2.
- ⑫ A 10' WIDE PRIVATE EASEMENT FOR STORM DRAIN PURPOSES OVER PARCEL 3 FOR THE BENEFIT OF PARCEL 2.
- ⑬ A PRIVATE EASEMENT FOR DETENTION BASIN PURPOSES OVER PARCEL 5 FOR THE BENEFIT OF PARCEL 7.
- ⑭ A PRIVATE EASEMENT FOR DETENTION BASIN PURPOSES OVER PARCEL 5 FOR THE BENEFIT OF PARCELS 6 AND 7.
- ⑮ A PRIVATE EASEMENT FOR DETENTION BASIN PURPOSES OVER PARCEL 5 FOR THE BENEFIT OF PARCEL 4.
- ⑯ A PRIVATE EASEMENT FOR DETENTION BASIN PURPOSES OVER PARCEL 5 FOR THE BENEFIT OF PARCEL 6.
- ⑰ A 10' WIDE PRIVATE EASEMENT FOR WATER PURPOSES OVER PARCEL 4 FOR THE BENEFIT OF PARCELS 1 AND 3.
- ⑱ A 10' WIDE PRIVATE EASEMENT FOR WATER PURPOSES OVER PARCEL 3 FOR THE BENEFIT OF PARCEL 1.
- ⑲ A 5' WIDE PRIVATE EASEMENT FOR WATER PURPOSES OVER PARCEL 6 FOR THE BENEFIT OF PARCEL 7.
- ⑳ A 3' WIDE PRIVATE EASEMENT FOR BUILDING MAINTENANCE PURPOSES OVER PARCEL 5 FOR THE BENEFIT OF PARCEL 2.

NOTE:

SEE SHEET 3 OF 5 FOR SURVEYOR'S NOTES.

SEE SHEET 5 OF 5 FOR DEDICATED AND RESERVED EASEMENT DETAILS.

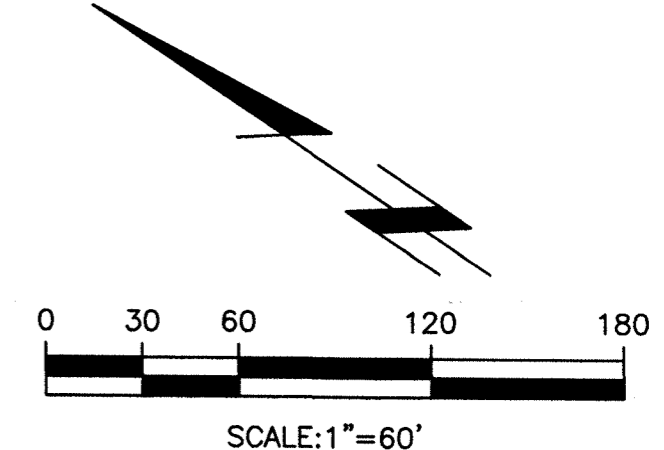

MAGNOLIA AVENUE

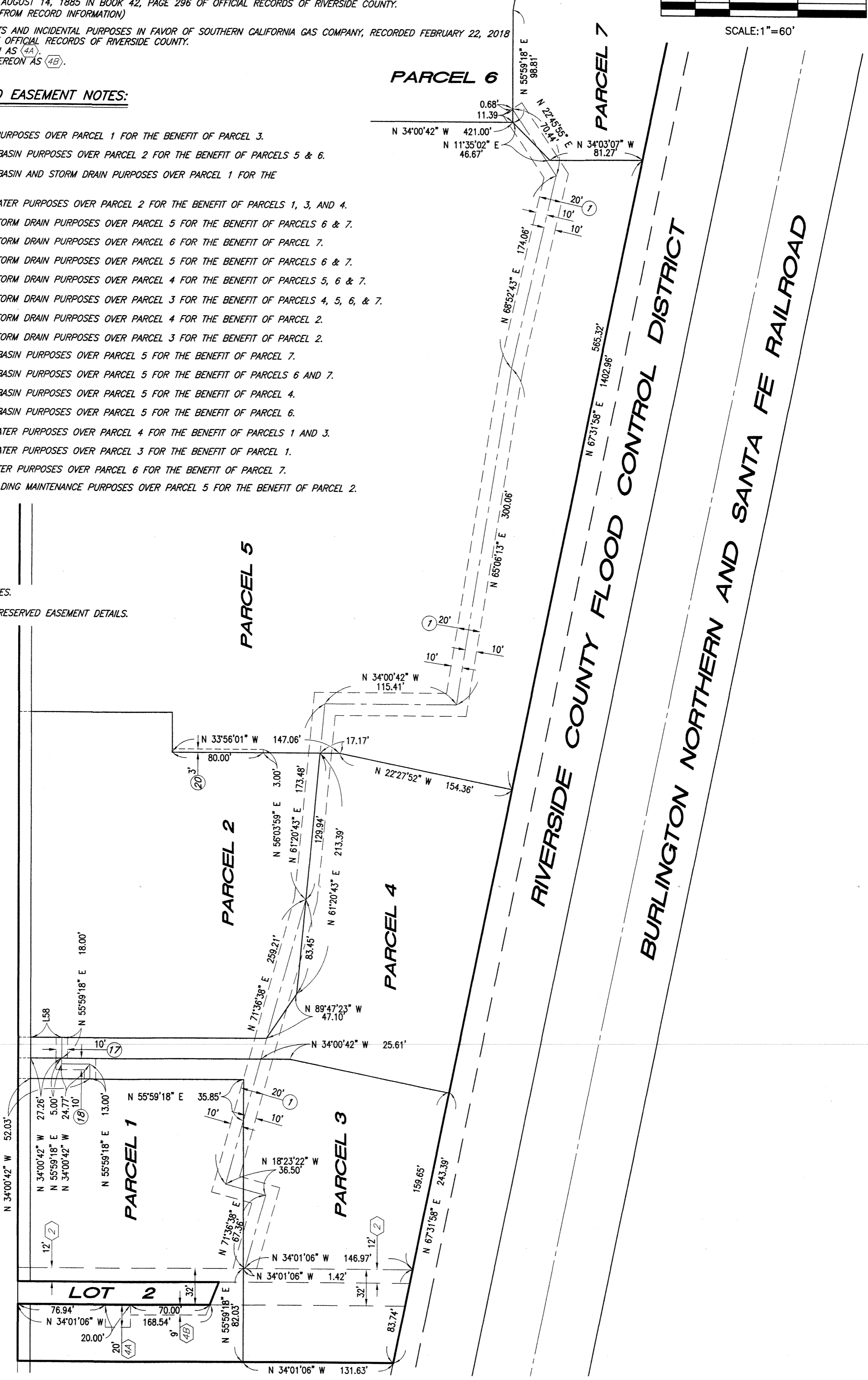

copy 2/14/16

copy 244/65

IN THE CITY OF RIVERSIDE, COUNTY OF RIVERSIDE, STATE OF CALIFORNIA

PARCEL MAP NO. 34605

BEING A SUBDIVISION OF A PORTION OF LOTS 1, 2 AND 3 OF BLOCK 51 OF LANDS OF RIVERSIDE LAND AND IRRIGATING COMPANY, AS PER MAP RECORDED IN BOOK 1, PAGE 72 OF MAPS, LOCATED IN PROTRACTED SECTION 22, T.3S., R.6W., IN RANCHO EL SOBRANTE DE SAN JACINTO, RECORDED IN BOOK 7, PAGE 10, MAPS IN THE OFFICE OF THE COUNTY RECORDER OF SAN BERNARDINO COUNTY.

MAGNOLIA AVENUE

MAGNOLIA AVENUE

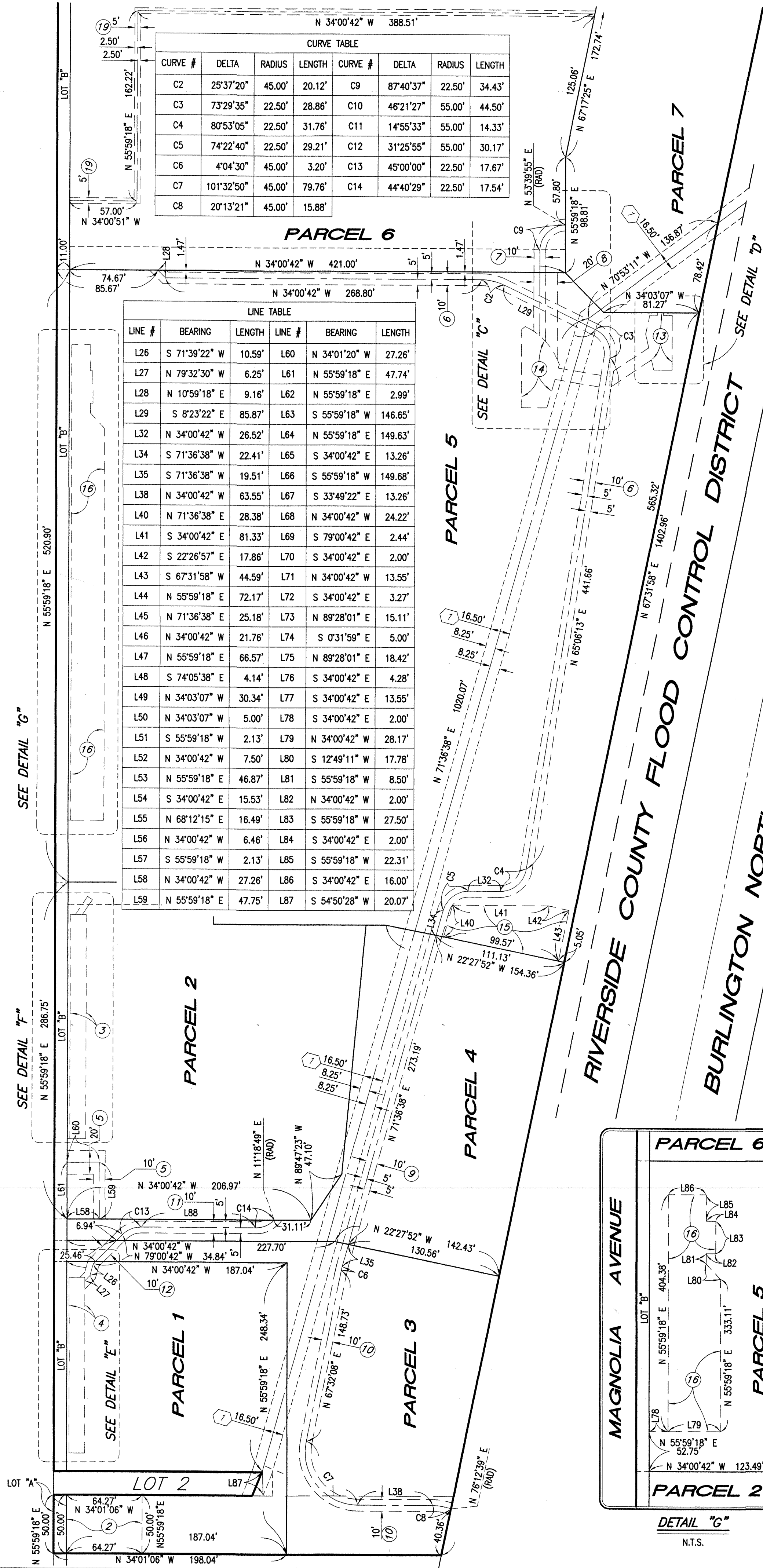

CURVE #	DELTA	RADIUS	LENGTH	CURVE #	DELTA	RADIUS	LENGTH
C2	25°37'20"	45.00'	20.12'	C9	87°40'37"	22.50'	34.43'
C3	73°29'35"	22.50'	28.86'	C10	46°21'27"	55.00'	44.50'
C4	80°53'05"	22.50'	31.76'	C11	14°55'33"	55.00'	14.33'
C5	74°22'40"	22.50'	29.21'	C12	31°25'55"	55.00'	30.17'
C6	4°04'30"	45.00'	3.20'	C13	45°00'00"	22.50'	17.67'
C7	101°32'50"	45.00'	79.76'	C14	44°40'29"	22.50'	17.54'
C8	20°13'21"	45.00'	15.88'				

LINE #	BEARING	LENGTH	LINE #	BEARING	LENGTH
L26	S 71°39'22" W	10.59'	L60	N 34°01'20" W	27.26'
L27	N 79°32'30" W	6.25'	L61	N 55°59'18" E	47.74'
L28	N 10°59'18" E	9.16'	L62	N 55°59'18" E	2.99'
L29	S 8°23'22" E	85.87'	L63	S 55°59'18" W	146.65'
L32	N 34°00'42" W	26.52'	L64	N 55°59'18" E	149.63'
L34	S 71°36'38" W	22.41'	L65	S 34°00'42" E	13.26'
L35	S 71°36'38" W	19.51'	L66	S 55°59'18" W	149.68'
L38	N 34°00'42" W	63.55'	L67	S 33°49'22" E	13.26'
L40	N 71°36'38" E	28.38'	L68	N 34°00'42" W	24.22'
L41	S 34°00'42" E	81.33'	L69	S 79°00'42" E	2.44'
L42	S 22°26'57" E	17.86'	L70	S 34°00'42" E	2.00'
L43	S 67°31'58" W	44.59'	L71	N 34°00'42" W	13.55'
L44	N 55°59'18" E	72.17'	L72	S 34°00'42" E	3.27'
L45	N 71°36'38" E	25.18'	L73	N 89°28'01" E	15.11'
L46	N 34°00'42" W	21.76'	L74	S 0°31'59" E	5.00'
L47	N 55°59'18" E	66.57'	L75	N 89°28'01" E	18.42'
L48	S 74°05'38" E	4.14'	L76	S 34°00'42" E	4.28'
L49	N 34°03'07" W	30.34'	L77	S 34°00'42" E	13.55'
L50	N 34°03'07" W	5.00'	L78	S 34°00'42" E	2.00'
L51	S 55°59'18" W	2.13'	L79	N 34°00'42" W	28.17'
L52	N 34°00'42" W	7.50'	L80	S 12°49'11" W	17.78'
L53	N 55°59'18" E	46.87'	L81	S 55°59'18" W	8.50'
L54	S 34°00'42" E	15.53'	L82	N 34°00'42" W	2.00'
L55	N 68°12'15" E	16.49'	L83	S 55°59'18" W	27.50'
L56	N 34°00'42" W	6.46'	L84	S 34°00'42" E	2.00'
L57	S 55°59'18" W	2.13'	L85	S 55°59'18" W	22.31'
L58	N 34°00'42" W	27.26'	L86	S 34°00'42" E	16.00'
L59	N 55°59'18" E	47.75'	L87	S 54°50'28" W	20.07'

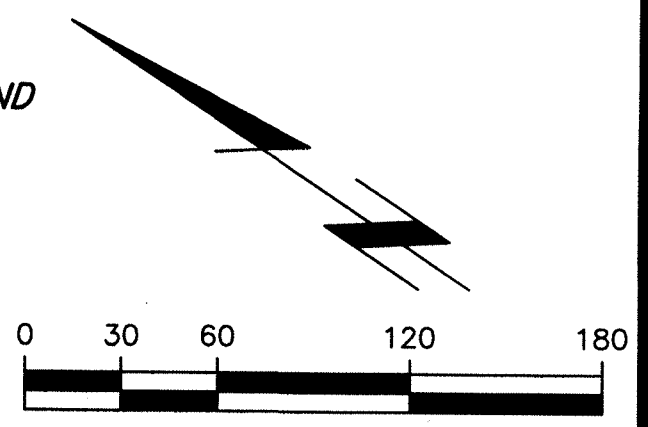

SCALE: 1"=60'

NOTE:

SEE SHEET 3 OF 5 FOR SURVEYOR'S NOTES.

SEE SHEET 4 OF 5 FOR EASEMENT NOTES.

SEE SHEET 4 OF 5 FOR RESERVED AND DEDICATED EASEMENT NOTES.

LINE #	BEARING	LENGTH
L88	N 34°00'42" W	97.01'
L89	N 24°53'41" W	37.98'
L90	N 65°06'13" E	10.00'
L91	N 24°53'41" W	36.84'
L92	S 71°36'38" W	3.22'
L93	S 55°59'18" W	73.43'
L94	N 43°18'35" E	12.03'
L95	S 67°58'27" E	35.80'
L96	N 65°06'13" E	13.69'
L97	S 67°58'27" E	41.26'
L98	N 43°18'35" E	8.76'

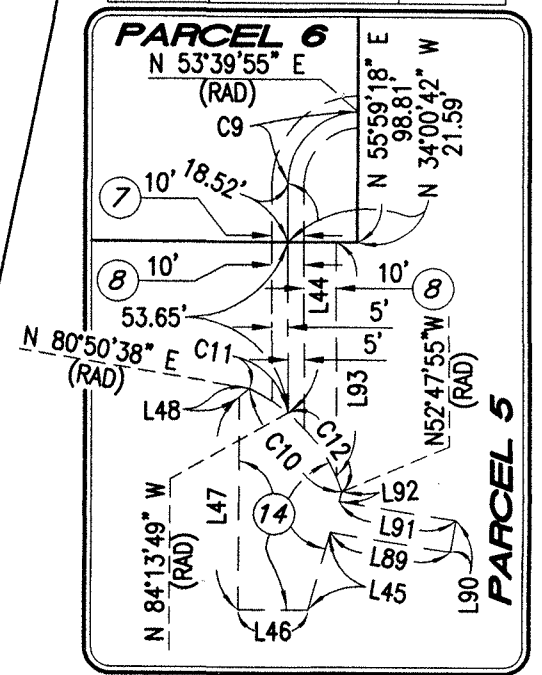

DETAIL "C"

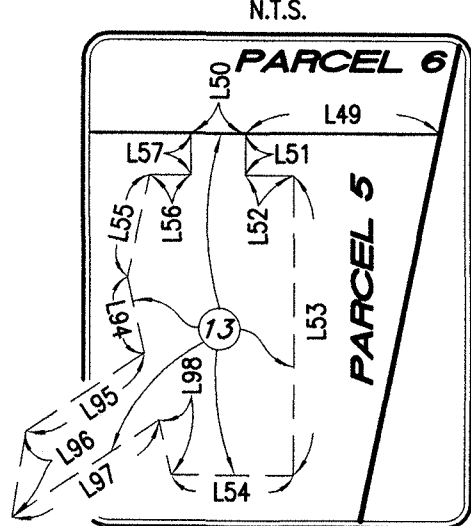

DETAIL "D"

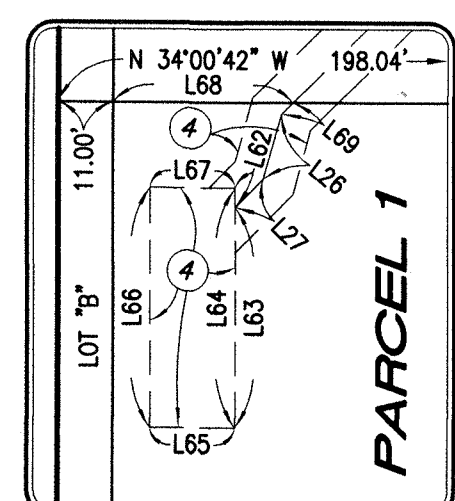

DETAIL "E"

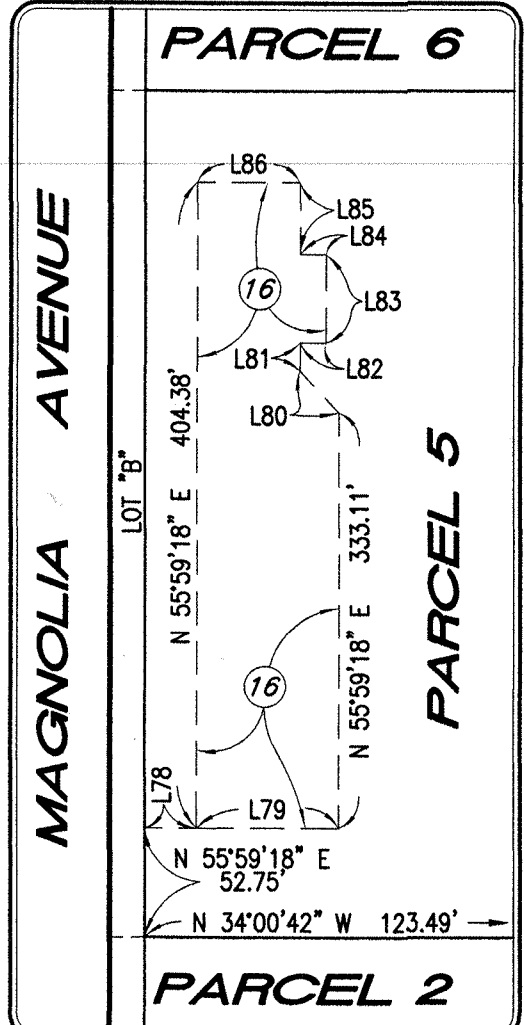

DETAIL "G"

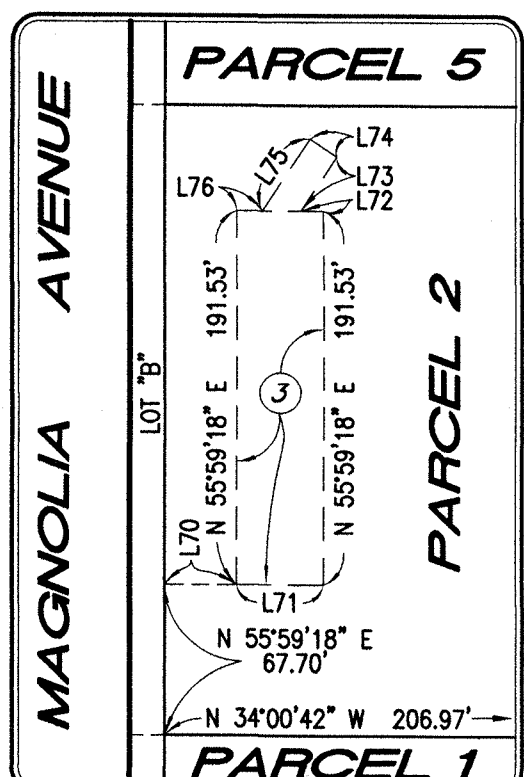

DETAIL "F"