

NEBRASKA AVENUE

HOLE AVENUE

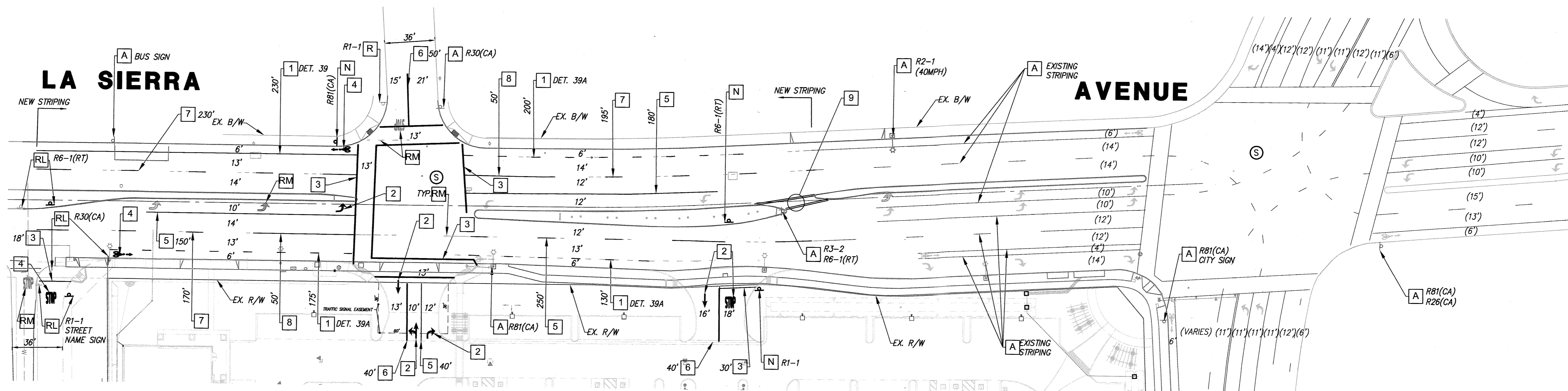

MOUNTAIN AVENUE

PIERCE STREET

TRAFFIC SIGNS ON THIS SHEET:

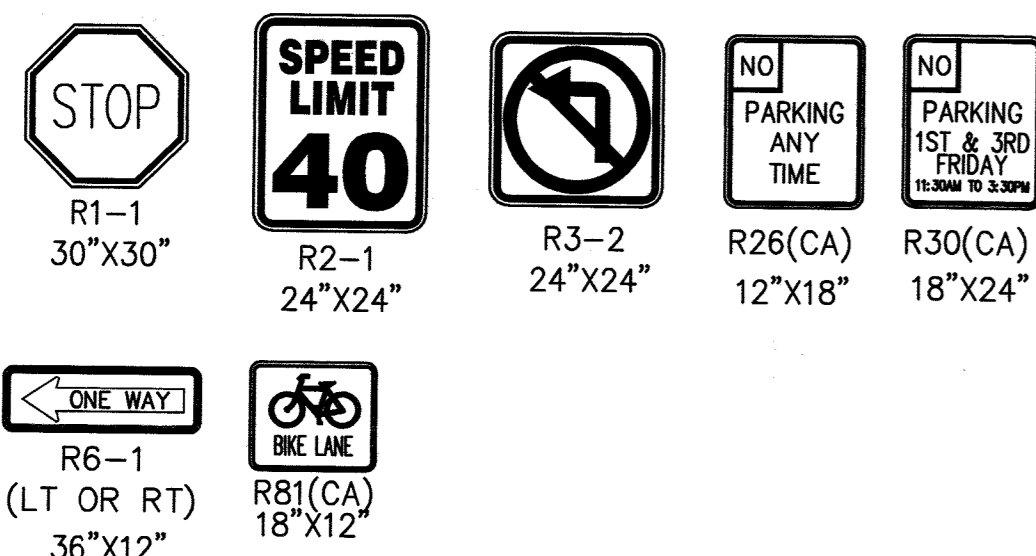

LEGEND:

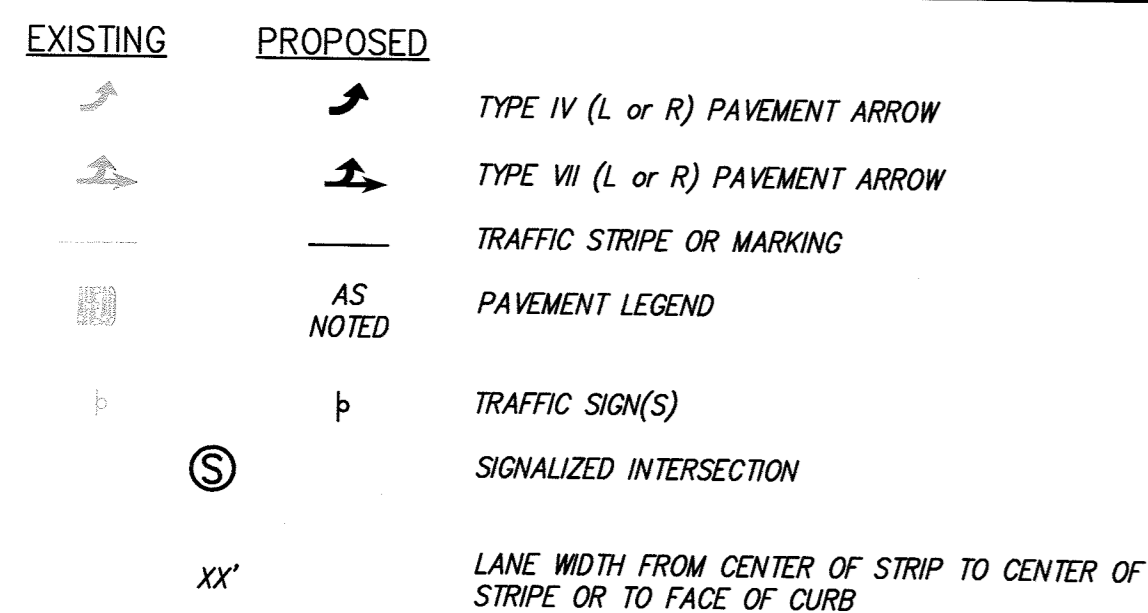

SIGNING AND STRIPING GENERAL NOTES:

- SIGNING AND STRIPING INSTALLATIONS SHALL CONFORM TO THE 2014 CALIFORNIA MANUAL ON UNIFORM TRAFFIC CONTROL DEVICE (CA MUTCD), THE STATE OF CALIFORNIA DEPARTMENT OF TRANSPORTATION (CALTRANS) STANDARD PLANS AND SPECIFICATIONS DATED 2010, AND ALL ADDENDUMS THERETO, AND THE CITY OF RIVERSIDE PUBLIC WORKS DEPARTMENT STANDARD DRAWINGS, CURRENT EDITION.
- ALL STRIPING, MARKINGS, AND LEGENDS SHALL BE REFLECTORIZED THERMOPLASTIC UNLESS OTHERWISE NOTED. THE CONTRACTOR SHALL PROVIDE AND INSTALL RAISED PAVEMENT MARKERS FOR ALL STRIPING, STRIPINGS, MARKINGS AND LEGENDS SHALL CONFORM TO THE LATEST CALTRANS STANDARD PLANS A20A THRU A20D AND A24A THRU A24E.
- PRIOR TO FINAL ACCEPTANCE OF STREET IMPROVEMENTS, ALL PAVEMENT STRIPING AND STENCILING WITHIN THE PERIMETER OF THE CONSTRUCTION AREA SHALL BE RESTORED TO LIKE NEW CONDITION, IN A MANNER MEETING THE APPROVAL OF THE CITY OF RIVERSIDE.
- THE CONTRACTOR SHALL BE RE-STRIPING EXISTING STRIPING AND CURB MARKINGS OBLITERATED BY NEW CONSTRUCTION, WHETHER OR NOT SHOWN ON THE PLANS FOR REPLACEMENT, AT NO COST TO THE CITY.
- AT LOCATIONS WHERE EXISTING PAINTED CURB IS TO BE RECONSTRUCTED, THE CONTRACTOR SHALL PAINT THE NEW AS SHOWN ON THE PLANS WITHIN 10 WORKING DAYS OF CURB CONSTRUCTION OR AS DIRECTED BY ENGINEER. THE PAINT SHALL BE WATER-BASED WITH 2-YEAR GUARANTEE AGAINST COLOR FADING. PRIOR TO THE START OF CONSTRUCTION, THE CONTRACTOR SHALL SUBMIT TO THE CITY WRITTEN PROOF OF THE MANUFACTURER'S 2-YEAR GUARANTEE.
- ALL NEW STRIPING SHALL BE "CAT TRACKED" AND APPROVED BY THE ENGINEER PRIOR TO FINAL INSTALLATION. THE CONTRACTOR SHALL NOTIFY THE ENGINEER AFTER COMPLETING LAYOUT AND AT LEAST 3 WORKING DAYS BEFORE COMMENCING INSTALLATION OF STRIPING, MARKINGS AND MARKERS.
- TRAFFIC SIGN FACE SHALL BE 3M DIAMOND GRADE DG3 REFLECTIVE SHEETING (ASTM XI) OR APPROVED EQUAL WITH PROTECTIVE GRAFTIT OVERLAY FILM OR AS OTHERWISE NOTED. ALL WARNING SIGNS SHALL HAVE A FLUORESCENT YELLOW BACKGROUND AND SCHOOL SIGNS NOTED SHALL HAVE A FLUORESCENT YELLOW-GREEN BACKGROUND.
- SIGNS SHALL BE STANDARD SIZE UNLESS NOTED OTHERWISE. PRIOR TO INSTALLATION, NEW SIGNS SHALL BE APPROVED BY THE CITY OF RIVERSIDE. EXACT LOCATIONS OF SIGNS SHALL BE DETERMINED BY THE CITY ENGINEER.
- ALL EXISTING SIGNS AND POSTS TO BE REMOVED SHALL BE DELIVERED TO THE CITY OF RIVERSIDE SIGN DEPARTMENT.
- WHEN PAINT IS SPECIFIED, TRAFFIC STRIPES AND MARKINGS SHALL BE APPLIED IN TWO COATS. A MINIMUM OF SEVEN DAYS SHALL BE PROVIDED BETWEEN FIRST AND SECOND COATS.
- STRIPING SHALL BE APPLIED WITHIN 48 HOURS OF SURFACE COURSE REPLACEMENT ON STREETS OPEN TO THE PUBLIC BE LEFT UNSTRIPED OVER A WEEKEND OR HOLIDAY.
- CONTRACTOR SHALL INSTALL NEW SIGN(S) AND/OR POST(S) PER CITY OF RIVERSIDE STANDARD DRAWING No. 684, SEE SPECIFICATIONS. 13. CONTRACTOR SHALL INSTALL NEW STREET NAME SIGNS AND POST PER CITY OF RIVERSIDE STANDARD DRAWING No. 682, SEE SPECIFICATIONS.
- ALL CONFLICTING STRIPING, PAVEMENT MARKINGS, LEGENDS, AND RAISED PAVEMENT MARKERS SHALL BE REMOVED EVEN IF NO SHOWN ON PLANS. REMOVALS PAINTED STRIPING, PAVEMENT MARKINGS AND LEGENDS SHALL BE DONE BY WET SANDBLASTING. REMOVALS OF THERMOPLASTIC STRIPING, PAVEMENT MARKINGS AND LEGENDS SHALL BE REMOVED BY WET SANDBLASTING, GRINDING OR OTHER APPROVED METHOD AND SHALL NOT DAMAGE THE PAVEMENT. "BLACK OUT" OF EXISTING DELINEATION IS NOT PERMITTED. ALL DAMAGED PAVEMENT DUE TO REMOVALS SHALL BE REPAIRED AS NECESSARY TO MAINTAIN A SMOOTH AND UNIFORM SURFACE OR AS DIRECTED BY THE ENGINEER. ALL STRIPING REMOVALS AND LEGENDS SHALL BE "FOG SEALED".
- WHERE APPLICABLE, OUTBOUND LANE LINE DETAILS SHALL COMMENCE AT THE CROSSWALK, MEANING THE PAINTED PORTION OF THE DETAIL SHALL JOIN THE CROSSWALK.

SIGNING AND STRIPING NOTES:

- INSTALL 6" WHITE LINE PER CALTRANS STD PLAN A20D DETAILS 39 OR 39A.
- INSTALL PAVEMENT ARROW PER CALTRANS STD PLAN A24A.
- INSTALL 12" WHITE CROSSWALK (10' CLEAR) OR LIMIT LINE PER CALTRANS STD PLAN A24E AND DETAIL "A".
- INSTALL PAVEMENT MARKING PER CALTRANS STD PLAN A24A-A24E.
- INSTALL 8" SOLID WHITE LANE LINE PER CALTRANS STD PLAN A20D, DETAIL 3B.
- INSTALL DOUBLE YELLOW LINE PER CALTRANS STD PLAN A20A, DETAIL 22.
- INSTALL 4" WHITE LINE PER CALTRANS STD PLAN A20A, DETAIL 9.
- INSTALL 4" WHITE SOLID (50').
- INSTALL DOUBLE YELLOW LINES (2 SETS) PER CALTRANS STD PLAN A20B, DETAIL 29.
- PROTECT IN PLACE
- FURNISH AND INSTALL SIGN(S) ON NEW POST AS INDICATED.
- REMOVE EXISTING SIGN(S)
- RELOCATE SIGN(S) AS INDICATED, PROVIDE MINIMUM 7' CLEARANCE AT ALL SIDEWALKS.
- REMOVE ALL CONFLICTING EXISTING STRIPING/PAVEMENT MARKING. FOG SEAL.

X-WALK DETAIL- DETAIL "A"

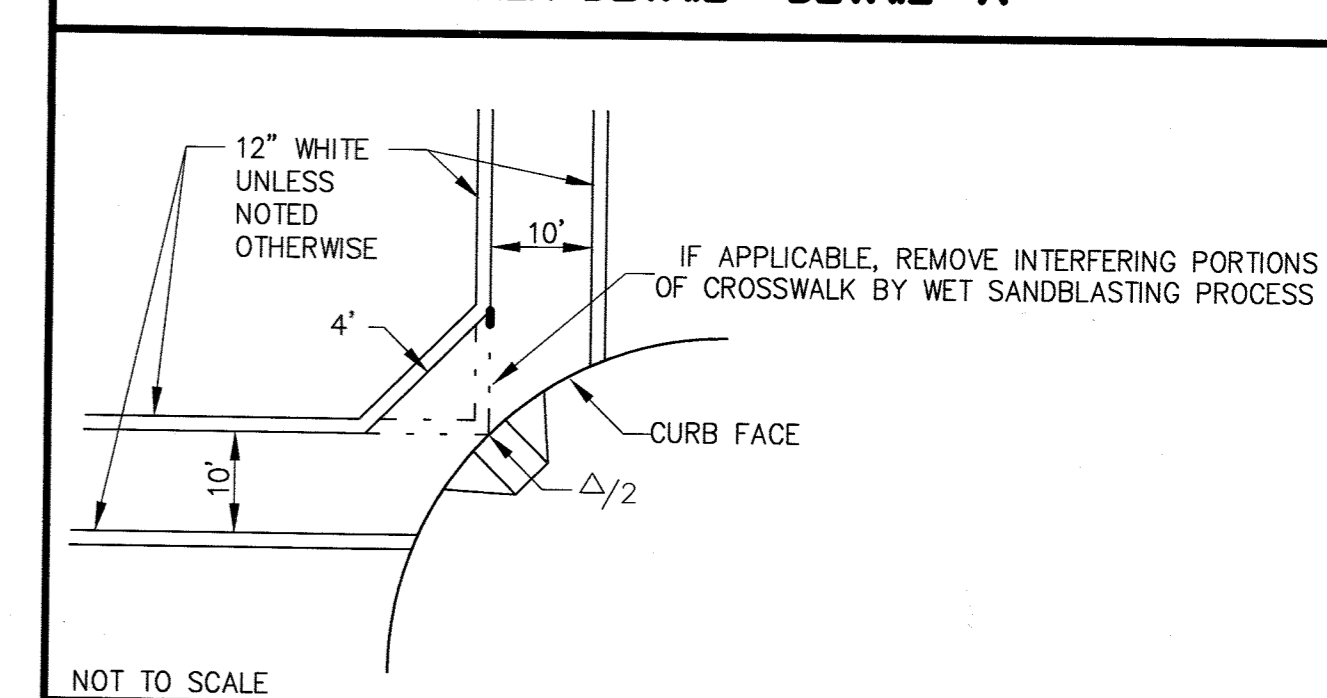

BIKE LANE LEGEND DETAIL - DETAIL "B"

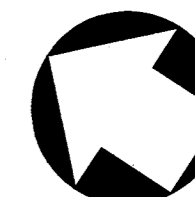
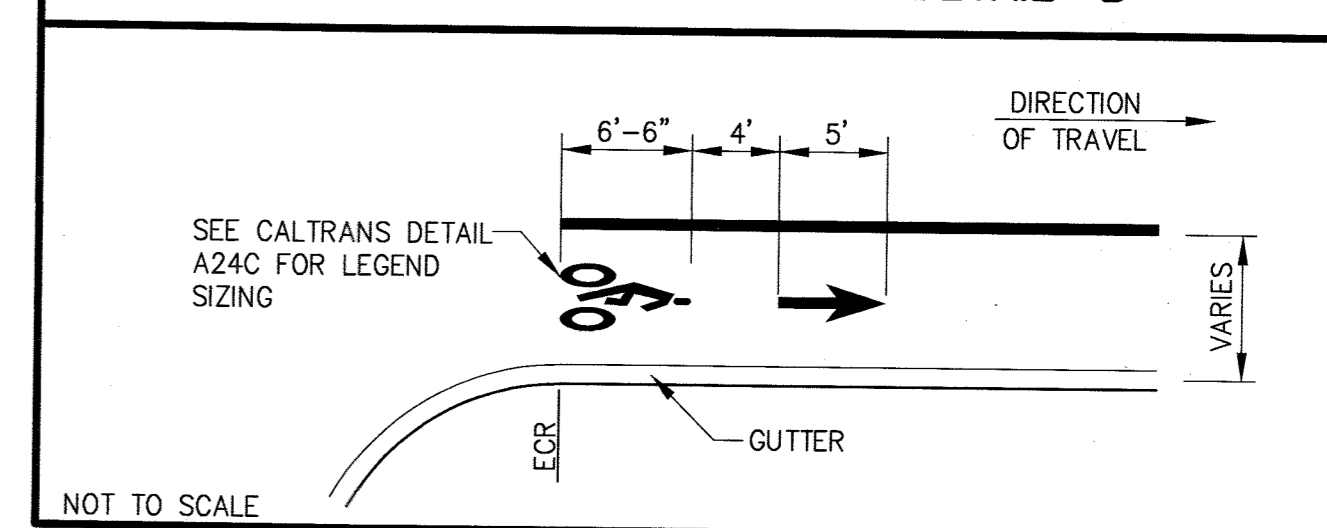

40' 20' 0' 40' 80'

GRAPHIC SCALE
Note: For reduced sized prints, original scale is in inches

DIGALERT
DIAL BEFORE YOU DIG
TWO WORKING DAYS BEFORE YOU DIG
TOLL FREE 1-800-227-2600
A PUBLIC SERVICE BY UNDERGROUND SERVICE ALERT
BENCHMARK: F2-03 1988 ELEV. = 725.201
CITY OF RIVERSIDE
FOUND P.K. NAIL AND CITY ENGINEER TAG "F2-03" IN THE MOST SOUTHERLY CURB RETURN AT PIERCE STREET AND GOLDEN AVENUE.

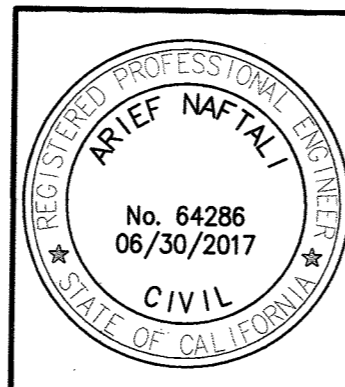

CITY BUSINESS CERTIFICATE NO. 0021337, EXP. 10/31/2015
PSOMAS
1500 IOWA AVENUE, SUITE 210
RIVERSIDE, CA 92507
(951) 787-8421 WWW.PSOMAS.COM

PREPARED BY: [Signature] R.C.E. NO. 64286 DATE: 9/29/2015

MARK DESIGNED BY: DRAWN BY: CHECKED BY:

**CITY OF RIVERSIDE, CALIFORNIA
PUBLIC WORKS DEPARTMENT**

APPROVED BY: [Signature] BY DATE: [Date]
ENGINEERING MANAGER: [Signature] DATE: 10/26/2015
TRAFFIC ENGINEERING: [Signature]
CONSTRUCTION MANAGEMENT: [Signature]

**CITY OF RIVERSIDE
SIGN & STRIPING PLAN
LA SIERRA AVENUE AT
NEBRASKA AVENUE**

XL-738

SHEET 1 of 1

J.N. 4MCK010200

HORIZ. SCALE: 1"=40' VERT. SCALE: N/A