

SIGNING AND STRIPING GENERAL NOTES:

- SIGNING AND STRIPING INSTALLATIONS SHALL CONFORM TO THE CALIFORNIA MANUAL ON UNIFORM TRAFFIC CONTROL DEVICES (CA MUTCD) ADOPTED 2014, THE STATE OF CALIFORNIA DEPARTMENT OF TRANSPORTATION (CALTRANS) STANDARD PLANS AND SPECIFICATIONS DATED 2015, AND ALL ADDENDUMS THERETO, AND THE CITY OF RIVERSIDE PUBLIC WORKS DEPARTMENT STANDARD DRAWINGS, CURRENT EDITION.
- ALL STRIPING, MARKINGS, AND LEGENDS SHALL BE REFLECTORIZED THERMOPLASTIC UNLESS OTHERWISE NOTED. THE CONTRACTOR SHALL PROVIDE AND INSTALL RAISED PAVEMENT MARKERS FOR ALL STRIPING, STRIPING, MARKINGS AND LEGENDS SHALL CONFORM TO THE LATEST CALTRANS STANDARD PLANS A20A THRU A20D AND A24A THRU A24E.
- PRIOR TO FINAL ACCEPTANCE OF STREET IMPROVEMENTS, ALL PAVEMENT STRIPING AND STENCILING WITHIN THE PERIMETER OF THE CONSTRUCTION AREA SHALL BE RESTORED TO LIKE NEW CONDITION, IN A MANNER MEETING THE APPROVAL OF THE CITY OF RIVERSIDE.
- THE CONTRACTOR SHALL RE-STRIP EXISTING STRIPING AND CURB MARKINGS OBLITERATED BY NEW CONSTRUCTION, WHETHER OR NOT SHOWN ON THE PLANS FOR REPLACEMENT, AT NO COST TO THE CITY.
- AT LOCATIONS WHERE EXISTING PAINTED CURB IS TO BE RECONSTRUCTED, THE CONTRACTOR SHALL PAINT THE NEW CURB AS SHOWN ON THE PLANS WITHIN 10 WORKING DAYS OF CURB CONSTRUCTION OR AS DIRECTED BY ENGINEER. THE PAINT SHALL BE WATER-BASED WITH 2-YEAR GUARANTEE AGAINST COLOR FADING. PRIOR TO THE START OF CONSTRUCTION, THE CONTRACTOR SHALL SUBMIT TO THE CITY WRITTEN PROOF OF THE MANUFACTURER'S 2-YEAR GUARANTEE.
- ALL NEW STRIPING SHALL BE "CAT TRACKED" AND APPROVED BY THE ENGINEER PRIOR TO FINAL INSTALLATION. THE CONTRACTOR SHALL NOTIFY THE ENGINEER AFTER COMPLETING LAYOUT AND AT LEAST 3 WORKING DAYS BEFORE COMMENCING INSTALLATION OF STRIPING, MARKINGS AND MARKERS.
- TRAFFIC SIGN FACE SHALL BE 3M DIAMOND GRADE DG3 REFLECTIVE SHEETING (ASTM XI) OR APPROVED EQUAL WITH PROTECTIVE GRAFFITI OVERLAY FILM OR AS OTHERWISE NOTED. ALL WARNING SIGNS SHALL HAVE A FLUORESCENT YELLOW BACKGROUND AND SCHOOL SIGNS NOTED SHALL HAVE A FLUORESCENT YELLOW-GREEN BACKGROUND.
- SIGNS SHALL BE STANDARD SIZE UNLESS NOTED OTHERWISE. PRIOR TO INSTALLATION, NEW SIGNS SHALL BE APPROVED BY THE CITY OF RIVERSIDE. EXACT LOCATIONS OF SIGNS SHALL BE DETERMINED BY THE CITY ENGINEER.
- ALL EXISTING SIGNS AND POSTS TO BE REMOVED SHALL BE DELIVERED TO THE CITY OF RIVERSIDE SIGN DEPARTMENT.
- WHEN PAINT IS SPECIFIED, TRAFFIC STRIPES AND MARKINGS SHALL BE APPLIED IN TWO COATS. A MINIMUM OF SEVEN DAYS SHALL BE PROVIDED BETWEEN FIRST AND SECOND COATS.
- STRIPING SHALL BE APPLIED WITHIN 48 HOURS OF SURFACE COURSE REPLACEMENT ON STREETS OPEN TO THE PUBLIC. IN NO CASE SHALL A NEWLY PAVED STREET OPEN TO THE PUBLIC BE LEFT UNSTRIPED OVER A WEEKEND OR HOLIDAY.
- CONTRACTOR SHALL INSTALL NEW SIGN(S) AND/OR POST(S) PER CITY OF RIVERSIDE STANDARD DRAWING No. 664, SEE SPECIFICATIONS.
- CONTRACTOR SHALL INSTALL NEW STREET NAME SIGNS AND POST PER CITY OF RIVERSIDE STANDARD DRAWING No. 662, SEE SPECIFICATIONS.
- ALL CONFLICTING STRIPING, PAVEMENT MARKINGS, LEGENDS, AND RAISED PAVEMENT MARKERS SHALL BE REMOVED EVEN IF NOT SHOWN ON PLANS. REMOVALS OF PAINTED STRIPING, PAVEMENT MARKINGS AND LEGENDS SHALL BE DONE BY WET SANDBLASTING. REMOVALS OF THERMOPLASTIC STRIPING, PAVEMENT MARKINGS AND LEGENDS SHALL BE REMOVED BY WET SANDBLASTING, GRINDING OR OTHER APPROVED METHOD AND SHALL NOT DAMAGE THE PAVEMENT. "BLACK OUT" OF EXISTING DELINEATION IS NOT PERMITTED. ALL DAMAGED PAVEMENT DUE TO REMOVALS SHALL BE REPAIRED AS NECESSARY TO MAINTAIN A SMOOTH AND UNIFORM SURFACE OR AS DIRECTED BY THE ENGINEER. ALL STRIPING REMOVALS AND LEGENDS SHALL BE "FOG SEALED".
- WHERE APPLICABLE, OUTBOUND LANE LINE DETAILS SHALL COMMENCE AT THE CROSSWALK, MEANING THE PAINTED PORTION OF THE DETAIL SHALL JOIN THE CROSSWALK.

CONSTRUCTION NOTES:

(E)	EXISTING SIGN TO REMAIN.
(IS)	INSTALL TRAFFIC SIGN, PER CALTRANS STANDARDS.
(PM)	INSTALL THERMOPLASTIC PAVEMENT MARKING PER CALTRANS STANDARDS.
(RL)	RELOCATE SIGN AND POST.
(RS)	REMOVE AND SALVAGE SIGN AND POST.
(TX)	INSTALL 12" SOLID WHITE THERMOPLASTIC MARKING. (10' BETWEEN 12" STRIPES)
(XX)	SANDBLAST CONFLICTING STRIPING. REMOVE EXISTING CONFLICTING REFLECTIVE PAVEMENT MARKINGS.
(22)	PAINT 4" DOUBLE YELLOW CENTERLINE STRIPE - DETAIL 22.
(38)	INSTALL 8" SOLID WHITE THERMOPLASTIC CHANNELIZING STRIPE - DETAIL 38.
(39)	PAINT 6" WHITE BIKE LANE STRIPE - DETAIL 39.
(39A)	PAINT 6" WHITE BIKE LANE INTERSECTION STRIPE - DETAIL 39A.

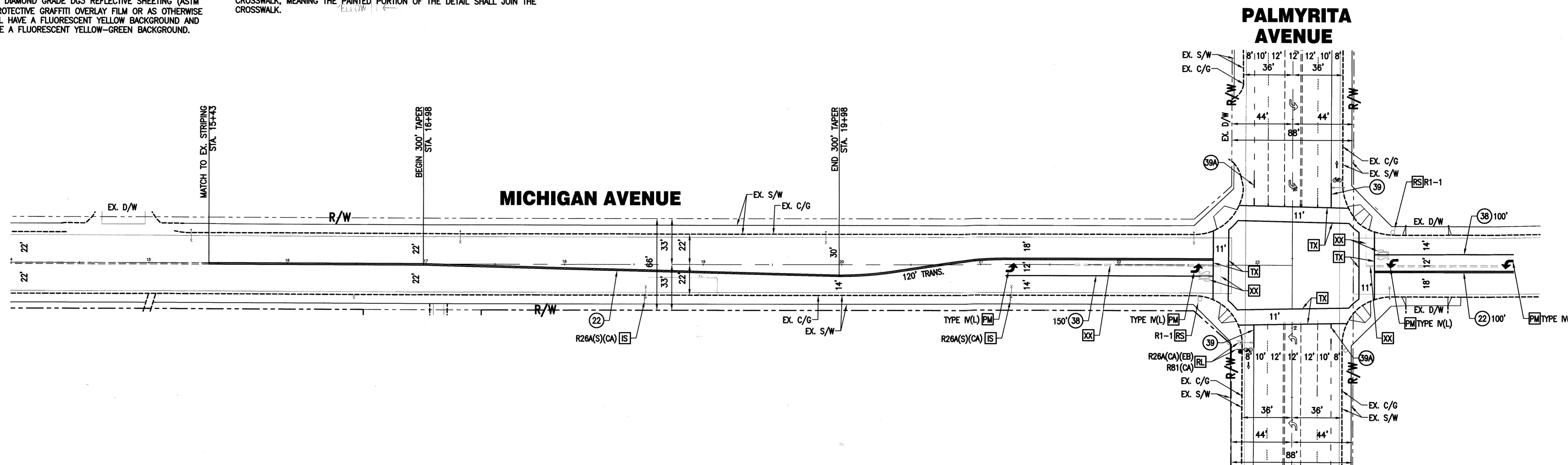

PALMYRITA AVENUE

MICHIGAN AVENUE

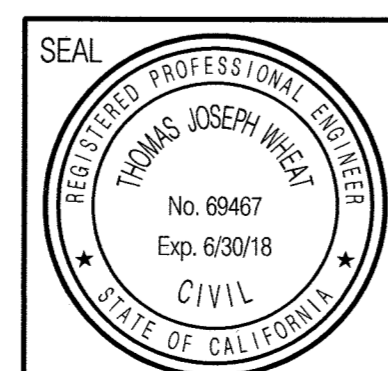
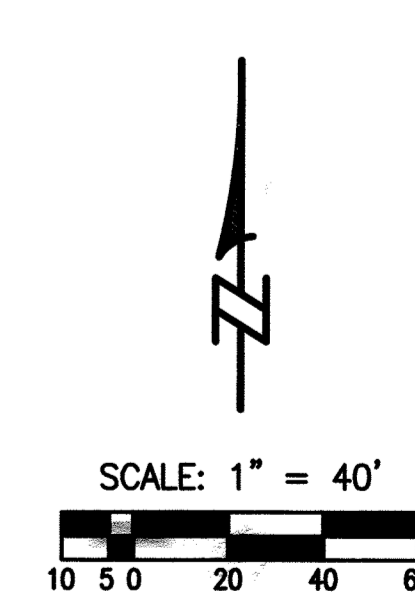

TJW ENGINEERING, INC.
 Traffic Engineering & Transportation
 Planning Consultants
 6 Venture, Suite 265
 Irvine, CA 92618
 t: (949) 878-3509 f: (949) 878-3593
 www.tjwengineering.com

Thomas Joseph Wheat
 Date: 1/30/17
 R.C.E. No. 69467 Exp. 6/30/18

MARK	REVISIONS	APPR.	DATE

DESIGNED BY: KM DRAWN BY: CHECKED BY:

**CITY OF RIVERSIDE, CALIFORNIA
PUBLIC WORKS DEPARTMENT**

APPROVED BY	BY	DATE	APPROVED BY
PRINCIPAL ENGINEER			
TRAFFIC DIVISION		2-6-17	
CONSTRUCTION MGMT		2-7-17	
ENGINEERING MANAGER		2-7-17	

DATE: 2/7/17

SIGNING AND STRIPING PLAN
 PALMYRITA AVENUE AT
 MICHIGAN AVENUE

HORIZONTAL SCALE: 1" = 40'

ACCT. NO.
XL-753
 SHEET 1 OF 1