

RUTLAND AVE.

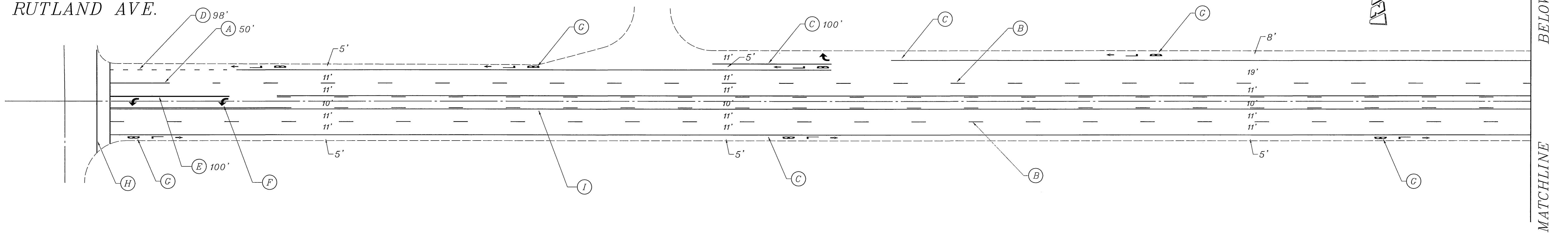

BEN LOMAND WAY

LAKE ST.

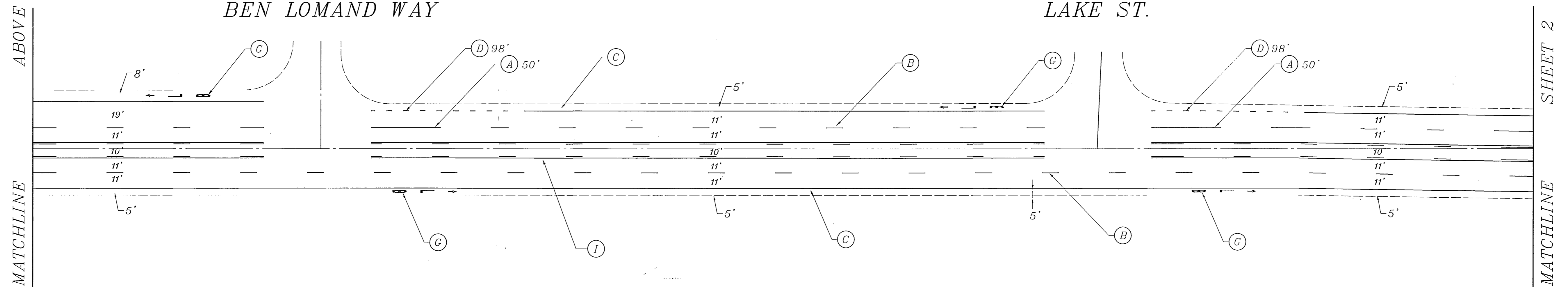

STRIPING & MARKING LEGEND

- (A) 4" SOLID WHITE STRIPE
- (B) 4" DASH WHITE STRIPE (12' STRIPE, 36' GAP)
- (C) 6" SOLID WHITE STRIPE
- (D) 6" DASH WHITE STRIPE (4' STRIPE, 8' GAP)
- (E) 8" SOLID WHITE STRIPE
- (F) SOLID WHITE ARROW
- (G) SOLID WHITE BIKE LANE STENCIL W/ ARROW
- (H) 12" SOLID WHITE STRIPE
- (I) TWO WAY LEFT TURN



ENGINEER IN RESPONSIBLE CHARGE
 FRAN DUNAJSKI
 DATE 9/28/01

MARK	REVISIONS	APPR	DATE

CITY OF RIVERSIDE, CALIFORNIA
 DEPARTMENT OF PUBLIC WORKS

APPROVED BY	BY	DATE
PRINCIPAL ENGINEER	<i>[Signature]</i>	10/14/01
P.W. INSPECTION	<i>[Signature]</i>	10/14/01
TRAFFIC DIVISION		
PUBLIC UTILITIES		

STRIPING PLAN
 ARLINGTON AVENUE
 RUTLAND AVENUE TO
 VAN BUREN BOULEVARD

ACCT. NO. 9539227152-44030200
 XL-456
 SHEET 1 OF 2
 FILE NAME: XL456-1.DWC

SCALE: 1" = 40'

SHEET 1

MATCHLINE

COPPER LANTERN DR.

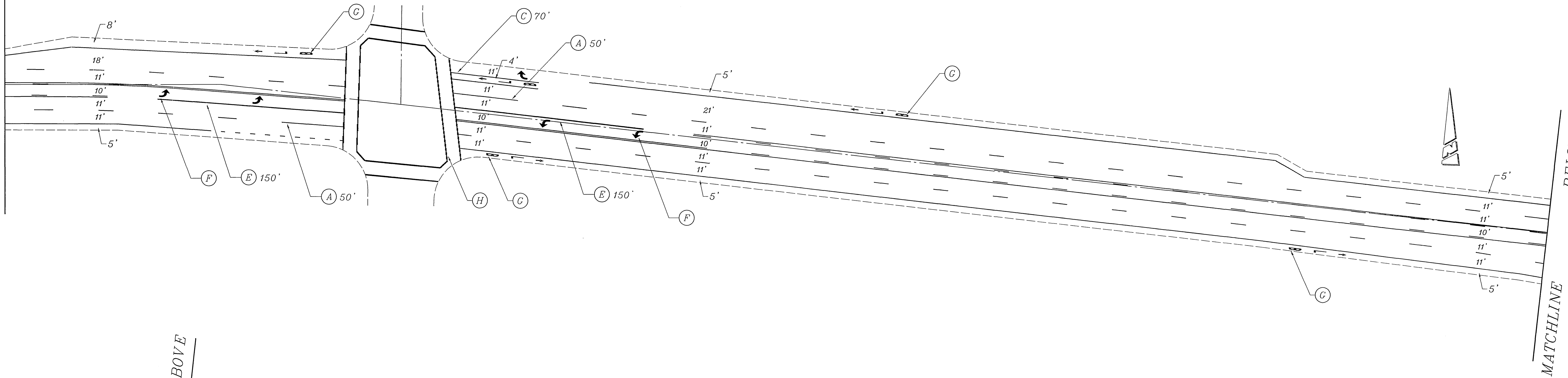

MATCHLINE

MATCHLINE

ABOVE

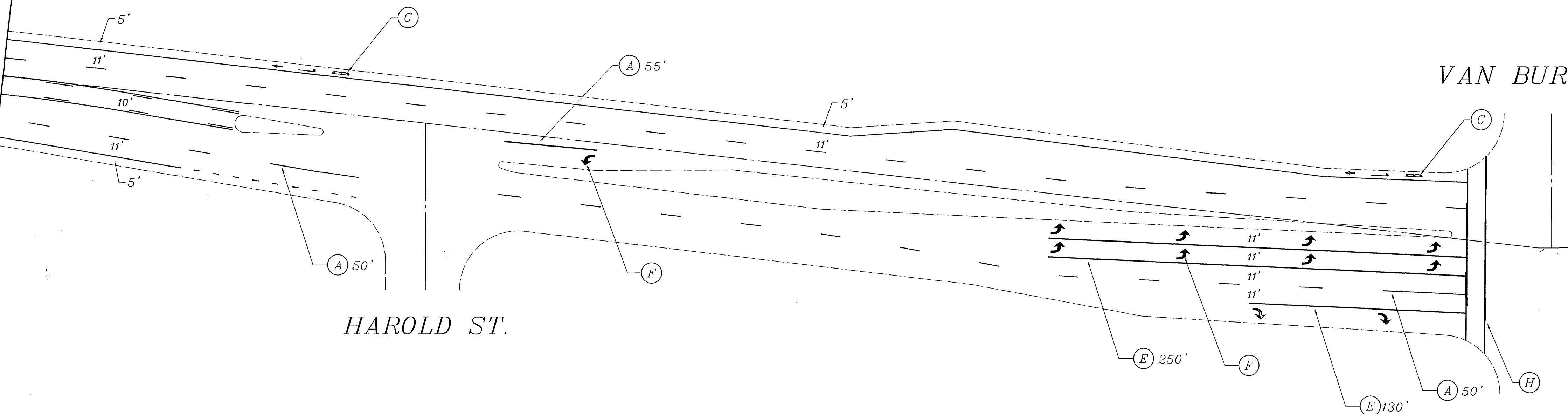

VAN BUREN BLVD.

HAROLD ST.

STRIPING & MARKING LEGEND

- (A) 4" SOLID WHITE STRIPE
- (B) 4" DASH WHITE STRIPE (12' STRIPE, 36' GAP)
- (C) 6" SOLID WHITE STRIPE
- (D) 6" DASH WHITE STRIPE (4' STRIPE, 8' GAP)
- (E) 8" SOLID WHITE STRIPE
- (F) SOLID WHITE ARROW
- (G) SOLID WHITE BIKE LANE STENCIL W/ ARROW
- (H) 12" SOLID WHITE STRIPE



ENGINEER IN RESPONSIBLE CHARGE
 FRAN DUNAJSKI
 DATE 9/28/01

MARK	REVISIONS	APPR	DATE

CITY OF RIVERSIDE, CALIFORNIA
 DEPARTMENT OF PUBLIC WORKS

APPROVED BY	BY	DATE	APPROVED BY
ENGINEERING MANAGER			DIRECTOR OF PUBLIC WORKS
PRINCIPAL ENGINEER		9/28/01	
P.W. INSPECTION		10/4/01	
TRAFFIC DIVISION			
PUBLIC UTILITIES			

DESIGNED BY MAC DRAWN BY MAC CHECKED BY

STRIPING PLAN
 ARLINGTON AVENUE
 RUTLAND AVENUE TO
 VAN BUREN BOULEVARD

SCALE: 1" = 40'

ACCT. NO. 9539227152-44030200
 XL-456
 SHEET 2 OF 2
 FILE NAME: XL456-2.DWG